

A
B
C

SECTION SC

STARTING & CHARGING SYSTEM

CONTENTS

<p>PRECAUTIONS 2</p> <p style="padding-left: 20px;">Precautions for Supplemental Restraint System (SRS) "AIR BAG" and "SEAT BELT PRE-TENSIONER" 2</p> <p style="padding-left: 20px;">Wiring Diagrams and Trouble Diagnosis 2</p> <p>PREPARATION 3</p> <p style="padding-left: 20px;">Special Service Tools 3</p> <p style="padding-left: 20px;">Commercial Service Tools 3</p> <p>BATTERY 4</p> <p style="padding-left: 20px;">How to Handle Battery 4</p> <p style="padding-left: 40px;">METHODS OF PREVENTING OVER-DISCHARGE 4</p> <p style="padding-left: 40px;">CHECKING ELECTROLYTE LEVEL 5</p> <p style="padding-left: 40px;">SPECIFIC GRAVITY CHECK 5</p> <p style="padding-left: 40px;">CHARGING THE BATTERY 6</p> <p style="padding-left: 20px;">Trouble Diagnosis with Battery/Starting/Charging</p> <p style="padding-left: 40px;">System Tester 6</p> <p style="padding-left: 40px;">DIAGNOSTIC RESULT ITEM CHART 8</p> <p style="padding-left: 20px;">Removal and Installation 8</p> <p style="padding-left: 40px;">REMOVAL 8</p> <p style="padding-left: 40px;">INSTALLATION 8</p> <p>STARTING SYSTEM 9</p> <p style="padding-left: 20px;">System Description 9</p> <p style="padding-left: 20px;">Wiring Diagram — START — 10</p> <p style="padding-left: 20px;">Trouble Diagnosis with Battery/Starting/Charging</p> <p style="padding-left: 40px;">System Tester 11</p> <p style="padding-left: 40px;">DIAGNOSTIC RESULT ITEM CHART 11</p> <p style="padding-left: 40px;">WORK FLOW 12</p> <p style="padding-left: 40px;">DIAGNOSTIC PROCEDURE 1 13</p> <p style="padding-left: 40px;">DIAGNOSTIC PROCEDURE 2 14</p>	<p style="padding-left: 20px;">MINIMUM SPECIFICATION OF CRANKING VOLTAGE REFERENCING COOLANT TEMPERATURE 14</p> <p style="padding-left: 20px;">Removal and Installation 15</p> <p style="padding-left: 40px;">REMOVAL 15</p> <p style="padding-left: 40px;">INSTALLATION 15</p> <p style="padding-left: 20px;">Disassembly and Assembly 16</p> <p style="padding-left: 20px;">Inspection After Disassembly 16</p> <p style="padding-left: 40px;">PINION/CLUTCH CHECK 16</p> <p>CHARGING SYSTEM 17</p> <p style="padding-left: 20px;">System Description 17</p> <p style="padding-left: 20px;">Wiring Diagram — CHARGE — 18</p> <p style="padding-left: 20px;">Trouble Diagnosis with Battery/Starting/Charging</p> <p style="padding-left: 40px;">System Tester 19</p> <p style="padding-left: 40px;">DIAGNOSTIC RESULT ITEM CHART 20</p> <p style="padding-left: 40px;">WORK FLOW 21</p> <p style="padding-left: 40px;">DIAGNOSTIC PROCEDURE 1 22</p> <p style="padding-left: 40px;">DIAGNOSTIC PROCEDURE 2 23</p> <p style="padding-left: 40px;">DIAGNOSTIC PROCEDURE 3 24</p> <p style="padding-left: 40px;">DIAGNOSTIC PROCEDURE 4 25</p> <p style="padding-left: 40px;">DIAGNOSTIC PROCEDURE 5 26</p> <p style="padding-left: 40px;">MALFUNCTION INDICATOR 26</p> <p style="padding-left: 20px;">Removal and Installation 27</p> <p style="padding-left: 40px;">REMOVAL 27</p> <p style="padding-left: 40px;">INSTALLATION 28</p> <p style="padding-left: 20px;">Disassembly and Assembly 29</p> <p>SERVICE DATA AND SPECIFICATIONS (SDS) 30</p> <p style="padding-left: 20px;">Battery 30</p> <p style="padding-left: 20px;">Starter 30</p> <p style="padding-left: 20px;">Alternator 30</p>
---	--

A
B
C
D
E
F
G
H
I
J
SC
L
M

PRECAUTIONS

PRECAUTIONS

PFP:00011

Precautions for Supplemental Restraint System (SRS) “AIR BAG” and “SEAT BELT PRE-TENSIONER”

AKS004V9

The Supplemental Restraint System such as “AIR BAG” and “SEAT BELT PRE-TENSIONER”, used along with a front seat belt, helps to reduce the risk or severity of injury to the driver and front passenger for certain types of collision. This system includes seat belt switch inputs and dual stage front air bag modules. The SRS system uses the seat belt switches to determine the front air bag deployment, and may only deploy one front air bag, depending on the severity of a collision and whether the front occupants are belted or unbelted. Information necessary to service the system safely is included in the SRS and SB section of this Service Manual.

WARNING:

- To avoid rendering the SRS inoperative, which could increase the risk of personal injury or death in the event of a collision which would result in air bag inflation, all maintenance must be performed by an authorized NISSAN/INFINITI dealer.
- Improper maintenance, including incorrect removal and installation of the SRS, can lead to personal injury caused by unintentional activation of the system. For removal of Spiral Cable and Air Bag Module, see the SRS section.
- Do not use electrical test equipment on any circuit related to the SRS unless instructed to in this Service Manual. SRS wiring harnesses can be identified by yellow and/or orange harnesses or harness connectors.

Wiring Diagrams and Trouble Diagnosis

AKS002EA

When you read wiring diagrams, refer to the following:

- Refer to [GI-14, "How to Read Wiring Diagrams"](#) in GI section.
- Refer to [PG-2, "POWER SUPPLY ROUTING"](#) for power distribution circuit in PG section.

When you perform trouble diagnosis, refer to the following:

- Refer to [GI-10, "HOW TO FOLLOW TEST GROUPS IN TROUBLE DIAGNOSES"](#) in PG section.
- Refer to [GI-26, "How to Perform Efficient Diagnosis for an Electrical Incident"](#) in PG section.

PREPARATION

PREPARATION

PPF:00002

Special Service Tools

AKS00ADU

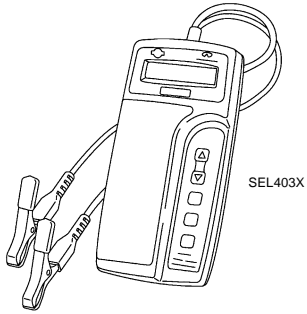
Tool number Tool name	Description
J-44373 Model 620 Battery/Starting/Charging system tester	 <p>SEL403X</p>

Commercial Service Tools

AKS00ADV

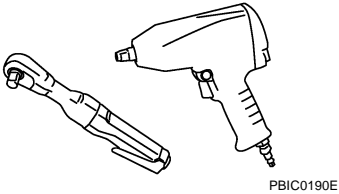
Tool number Tool name	Description
Power tool	 <p>PBIC0190E</p>

A

B

C

D

E

F

G

H

I

J

SC

L

M

BATTERY

BATTERY

PFP:00011

How to Handle Battery

AKS002EC

CAUTION:

- If it becomes necessary to start the engine with a booster battery and jumper cables, use a 12-volt booster battery.
- After connecting battery cables, ensure that they are tightly clamped to battery terminals for good contact.

METHODS OF PREVENTING OVER-DISCHARGE

The following precautions must be taken to prevent over-discharging a battery.

- The battery surface (particularly its top) should always be kept clean and dry.
- The terminal connections should be clean and tight.
- At every routine maintenance, check the electrolyte level. This also applies to batteries designated as “low maintenance” and “maintenance-free”.
- When the vehicle is not going to be used over a long period of time, disconnect the negative battery cable.
- Check the charge condition of the battery. Periodically check the specific gravity of the electrolyte. Keep a close check on charge condition to prevent over-discharge.

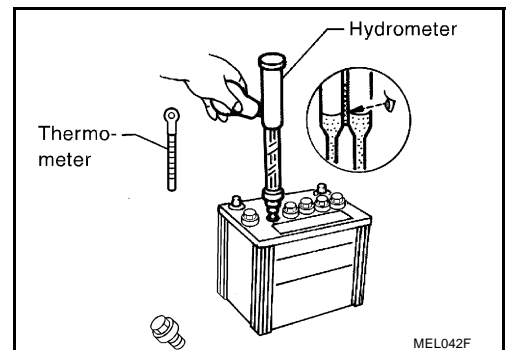
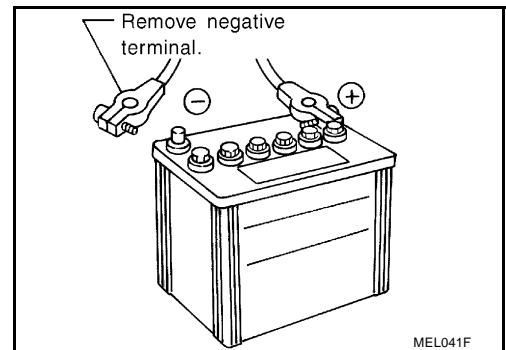
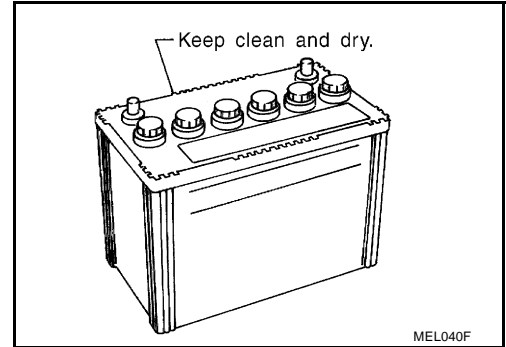

BATTERY

CHECKING ELECTROLYTE LEVEL

WARNING:

Do not allow battery fluid to come in contact with skin, eyes, fabrics, or painted surfaces. After touching a battery, do not touch or rub your eyes until you have thoroughly washed your hands. If acid contacts eyes, skin or clothing, immediately flush with water for 15 minutes and seek medical attention.

- Remove the cell plug using a suitable tool.
- Add distilled water up to the MAX level.

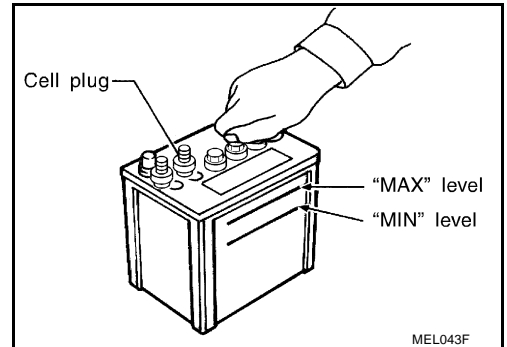

Sulphation

A battery will be completely discharged if it is left unattended for a long time and the specific gravity will become less than 1.100. This may result in sulphation on the cell plates.

To determine if a battery has been “sulphated”, note its voltage and current when charging it. As shown in the figure, less current and higher voltage are observed in the initial stage of charging sulphated batteries.

A sulphated battery may sometimes be brought back into service by means of a long, slow charge, 12 hours or more, followed by a battery capacity test.

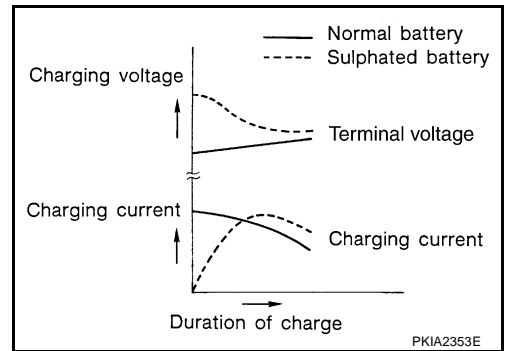

SPECIFIC GRAVITY CHECK

1. Read hydrometer and thermometer indications at eye level.
2. Use the chart below to correct your hydrometer reading according to electrolyte temperature.

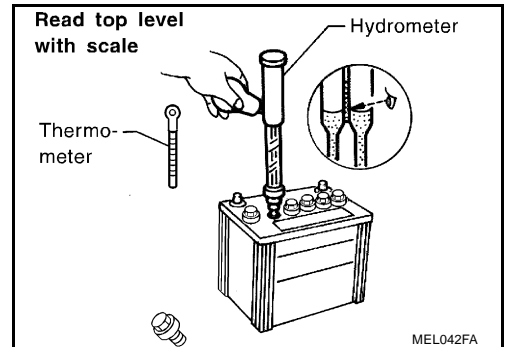

Hydrometer Temperature Correction

Battery electrolyte temperature °C (°F)	Add to specific gravity reading
71 (160)	0.032
66 (150)	0.028
60 (140)	0.024
54 (130)	0.020
49 (120)	0.016
43 (110)	0.012
38 (100)	0.008
32 (90)	0.004
27 (80)	0
21 (70)	-0.004

BATTERY

Battery electrolyte temperature °C (°F)	Add to specific gravity reading
16 (60)	-0.008
10 (50)	-0.012
4 (40)	-0.016
-1 (30)	-0.020
-7 (20)	-0.024
-12 (10)	-0.028
-18 (0)	-0.032

Corrected specific gravity	Approximate charge condition
1.260 - 1.280	Fully charged
1.230 - 1.250	3/4 charged
1.200 - 1.220	1/2 charged
1.170 - 1.190	1/4 charged
1.140 - 1.160	Almost discharged
1.110 - 1.130	Completely discharged

CHARGING THE BATTERY

CAUTION:

- Do not “quick charge” a fully discharged battery.
- Keep the battery away from open flame while it is being charged.
- When connecting the charger, connect the leads first, then turn on the charger. Do not turn on the charger first, as this may cause a spark.
- If battery electrolyte temperature rises above 55°C (131°F), stop charging. Always charge battery at a temperature below 55°C (131°F).

Charging Rates

Amps	Time
50	1 hour
25	2 hours
10	5 hours
5	10 hours

Do not charge at more than 50 ampere rate.

NOTE:

The ammeter reading on your battery charger will automatically decrease as the battery charges. This indicates that the voltage of the battery is increasing normally as the state of charge improves. The charging amps indicated above refer to initial charge rate.

- If, after charging, the specific gravity of any two cells varies more than 0.050, the battery should be replaced.

Trouble Diagnosis with Battery/Starting/Charging System Tester

AKS002ED

CAUTION:

When working with batteries, always wear appropriate eye protection.

NOTE:

- To ensure a complete and thorough diagnosis, the battery, starter and alternator test segments must be done as a set from start to finish.
- If battery surface charge is detected while testing, the tester will prompt you to turn on the headlamps to remove the surface charge.
- If necessary, the tester will prompt you to determine if the battery temperature is above or below 0°C (32°F). Choose the appropriate selection by pressing the up or down arrow button, then press “ENTER” to make the selection.

BATTERY

1. Turn off all loads on the vehicle electrical system. Clean or repair as necessary.
2. Visually inspect the battery, battery terminals and cable ends with ignition switch in "OFF" position.

NOTE:

The contact surface between the battery terminals, cable ends and tester leads must be clean for a valid test. A poor connection will prevent testing and a "CHECK CONNECTION" message will appear during the test procedures. If this occurs, clean the battery post and terminals, reconnect them and restart the test.

3. Connect the red tester lead clamp to the positive battery terminal, and the black to the negative terminal.
4. The tester will turn on automatically. Using the arrow keys, select "IN VEHICLE" on the tester and then press the "ENTER" key.

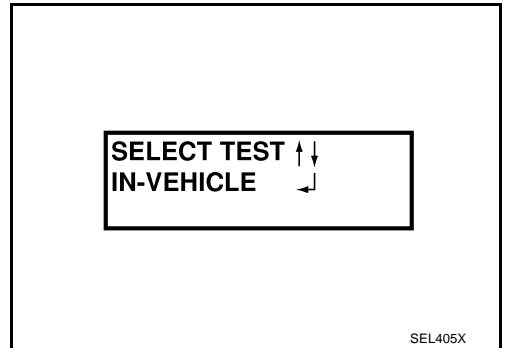
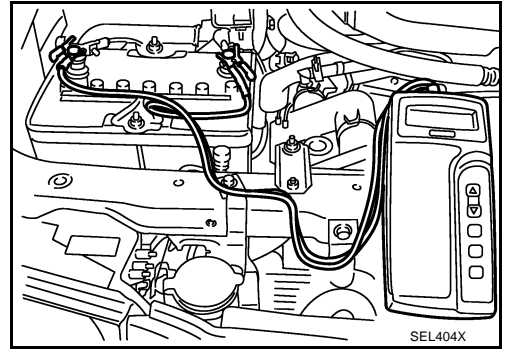

5. Locate the battery type and rating stamped or written on the top case of the battery to be tested.

NOTE:

The battery type and rating will have either of the following.

CCA: Cold Cranking Amps (490 CCA, 550 CCA, etc.)

JIS: Japanese Industrial Standard.

Battery is stamped with a number such as:

80D26L: 80 (rank of output), D (physical size-depth), 26 (width in cm). The last character L (post configuration) is not input into the tester.

The tester requires the rating for the battery be entered exactly as it is written or stamped on the battery. Do not attempt a CCA conversion for JIS stamped batteries. JIS must be input directly.

6. Using the arrow and "ENTER" keys alternately, select the battery type and rating.

NOTE:

The tester lists five choices; CCA, JIS, IEC, DIN, and EN. Only use CCA or JIS.

7. Press "ENTER" to begin the test. Diagnosis results are displayed on the tester. Refer to [SC-8, "DIAGNOSTIC RESULT ITEM CHART"](#).

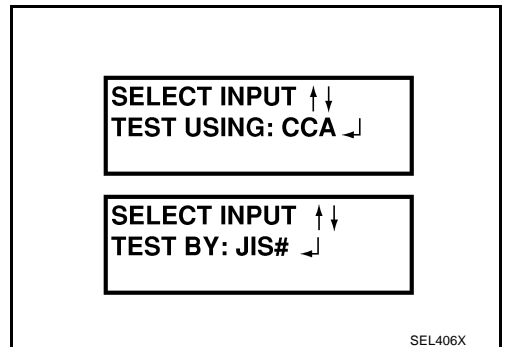

A
B
C
D
E
F
G
H
I
J
SC
L
M

BATTERY

8. Press "ENTER", then test output code is displayed. Record the test output code on the repair order.
9. Toggle back to the "DIAGNOSTIC SCREEN" for test results.

NOTE:

- If necessary, the tester will ask the user to determine if the battery has just been charged. Choose the appropriate selection by pressing the up or down arrow button and then press the "ENTER" button to make the selection.
- When testing a battery installed in a vehicle that has recently been driven, select "BEFORE CHANGE".
- If the battery has just been slow charged due to a "CHARGE & RETEST" decision by the tester, and the tester asks the user "BEFORE CHARGE/AFTER CHARGE", select "AFTER CHARGE".

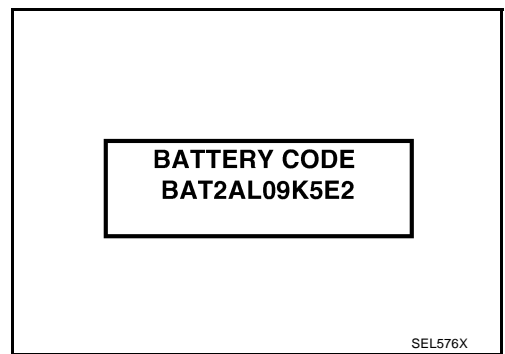

DIAGNOSTIC RESULT ITEM CHART

Diagnostic item	Service procedure
GOOD BATTERY	Battery is OK, go to "Trouble Diagnosis", "STARTING SYSTEM". Refer to SC-6. "Trouble Diagnosis with Battery/Starting/Charging System Tester" .
REPLACE BATTERY	Replace battery. Before replacing battery, clean the battery cable clamps and battery posts. Perform battery test again with Battery/Starting/Charging system tester. If second test result is "Replace Battery", then do so. Perform battery test again to confirm repair.
BAD CELL-REPLACE	Replace the battery. Perform battery test again with Battery/Starting/Charging system tester to confirm repair.
GOOD-RECHARGE	Perform the slow battery charging procedure. (Initial rate of charge is 10A for 12 hours.) Perform battery test again with Battery/Starting/Charging system tester.
CHARGE & RETEST	Perform the slow battery charging. (Initial rate of charge is 10A for 12 hours.) Perform battery test again with Battery/Starting/Charging system tester to confirm repair. NOTE: If the tester asks the user "BEFORE CHARGE/AFTER CHARGE", select "AFTER CHARGE".

Removal and Installation

REMOVAL

1. Disconnect negative battery cable and positive battery cable.
CAUTION:
When disconnecting, disconnect negative battery cable first.
2. Remove battery fix frame.
3. Remove battery case.
4. Remove battery.
5. Remove battery tray.

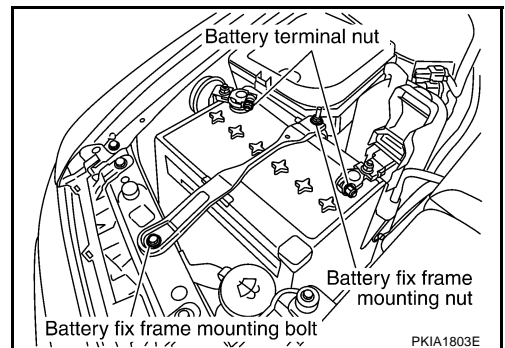

INSTALLATION

Install in the reverse order of removal.

CAUTION:

When connecting, connect positive battery cable first.

Battery fix frame mounting nut and bolt:

: 4.4 N·m (0.45 kg·m, 39 in·lb)

Battery terminal nut:

: 5.4 N·m (0.55 kg·m, 48 in·lb)

STARTING SYSTEM

STARTING SYSTEM

PFP:00011

System Description

AKS002EK

Power is supplied at all times

- through 50A fusible link (letter G, located in the fuse, fusible link and relay box)
- to ignition switch terminal 1.

With the ignition switch in the START position, power is supplied

- from ignition switch terminal 4
- to park/neutral position relay terminal 7.

Ground is supplied with the selector lever in the P or N position

- to TCM terminal 48 through park/neutral position relay terminals 1 and 2
- from body grounds E24 and E42.

Then park/neutral position switch is energized and power is supplied

- from park/neutral position relay terminal 6
- to starter motor terminal 1.

The starter motor plunger closes and provides a closed circuit between the battery and starter motor. The starter motor is grounded to the engine block. With power and ground supplied, cranking occurs and the engine starts.

A

B

C

D

E

F

G

H

I

J

SC

L

M

STARTING SYSTEM

Wiring Diagram — START —

AKS002EL

SC-START-01

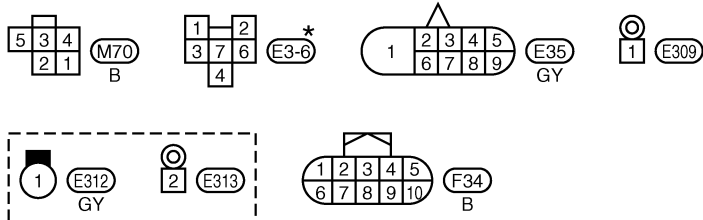
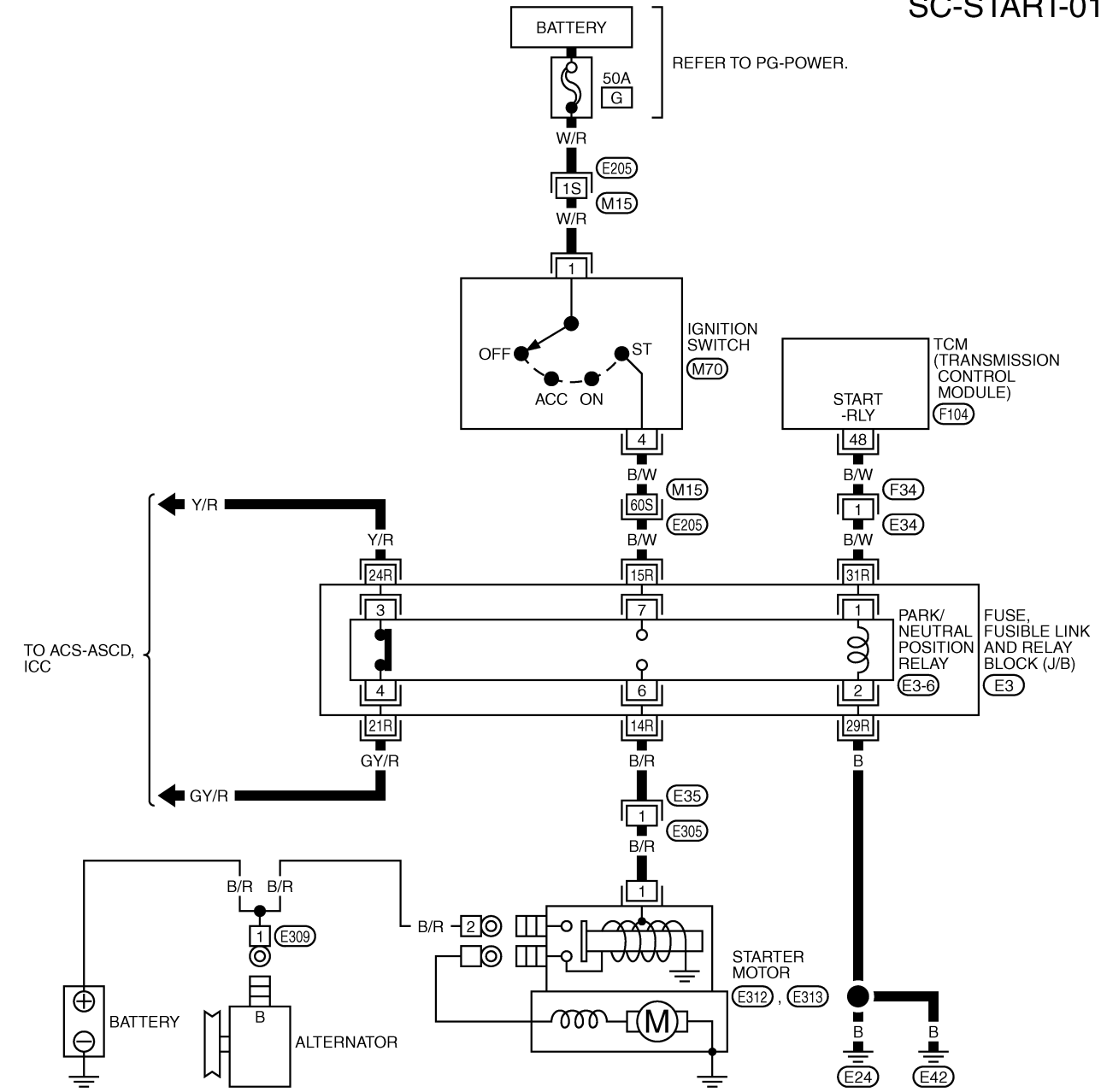

*: THIS CONNECTOR IS NOT SHOWN IN "HARNESS LAYOUT", PG SECTION.

REFER TO THE FOLLOWING.

- (E205) -SUPER MULTIPLE JUNCTION (SMJ)
- (E3) -FUSE, FUSIBLE LINK AND RELAY BLOCK (J/B)
- (F104) -ELECTRICAL UNITS

TKWA0514E

STARTING SYSTEM

Trouble Diagnosis with Battery/Starting/Charging System Tester

AKS002EM

NOTE:

To ensure a complete and thorough diagnosis, the battery, starter and alternator test segments must be done as a set from start to finish.

1. Turn off all loads on the vehicle electrical system.
2. Perform battery test with Battery/Starting/Charging system tester. Refer to [SC-6, "Trouble Diagnosis with Battery/Starting/Charging System Tester"](#).
3. Press "ENTER" to begin the starting system test.

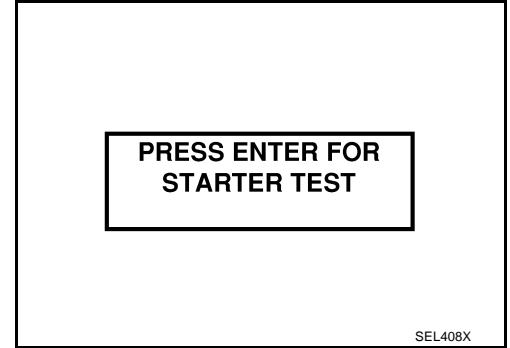

4. Start the engine.

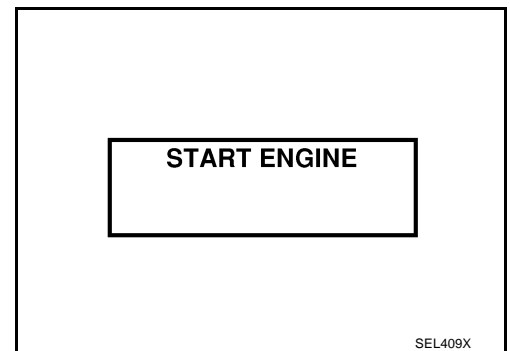

5. Diagnosis result is displayed on the tester. Refer to [SC-11, "DIAGNOSTIC RESULT ITEM CHART"](#).

NOTE:

- If the starter performs normally but the engine does not start, perform engine diagnosis.
- For intermittent "NO CRANK" or "NO STARTER OPERATION" incidents, refer to DIAGNOSTIC PROCEDURE 2.

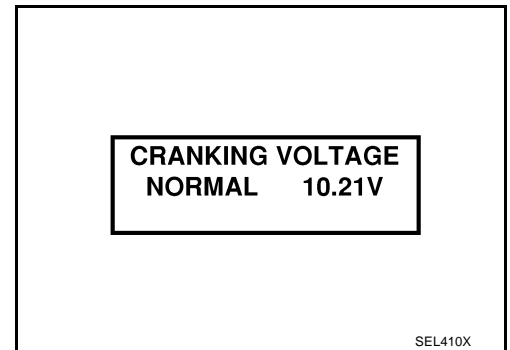

DIAGNOSTIC RESULT ITEM CHART

Diagnostic item	Service procedure
CRANKING VOLTAGE NORMAL	Go to SC-12, "WORK FLOW" .
CRANKING VOLTAGE LOW	Go to SC-12, "WORK FLOW" .
CHARGE BATTERY	Perform the slow battery charging procedure. (Initial rate of charge is 10A for 12 hours.) Perform battery test again with Battery/Starting/Charging system tester. Refer to SC-6, "Trouble Diagnosis with Battery/Starting/Charging System Tester" .
REPLACE BATTERY	Before replacing battery, clean the battery cable clamps and battery posts. Perform battery test again with Battery/Starting/Charging system tester. Refer to SC-6, "Trouble Diagnosis with Battery/Starting/Charging System Tester" . If second test result is "REPLACE BATTERY", then do so. Perform battery test again to confirm repair.

STARTING SYSTEM

WORK FLOW

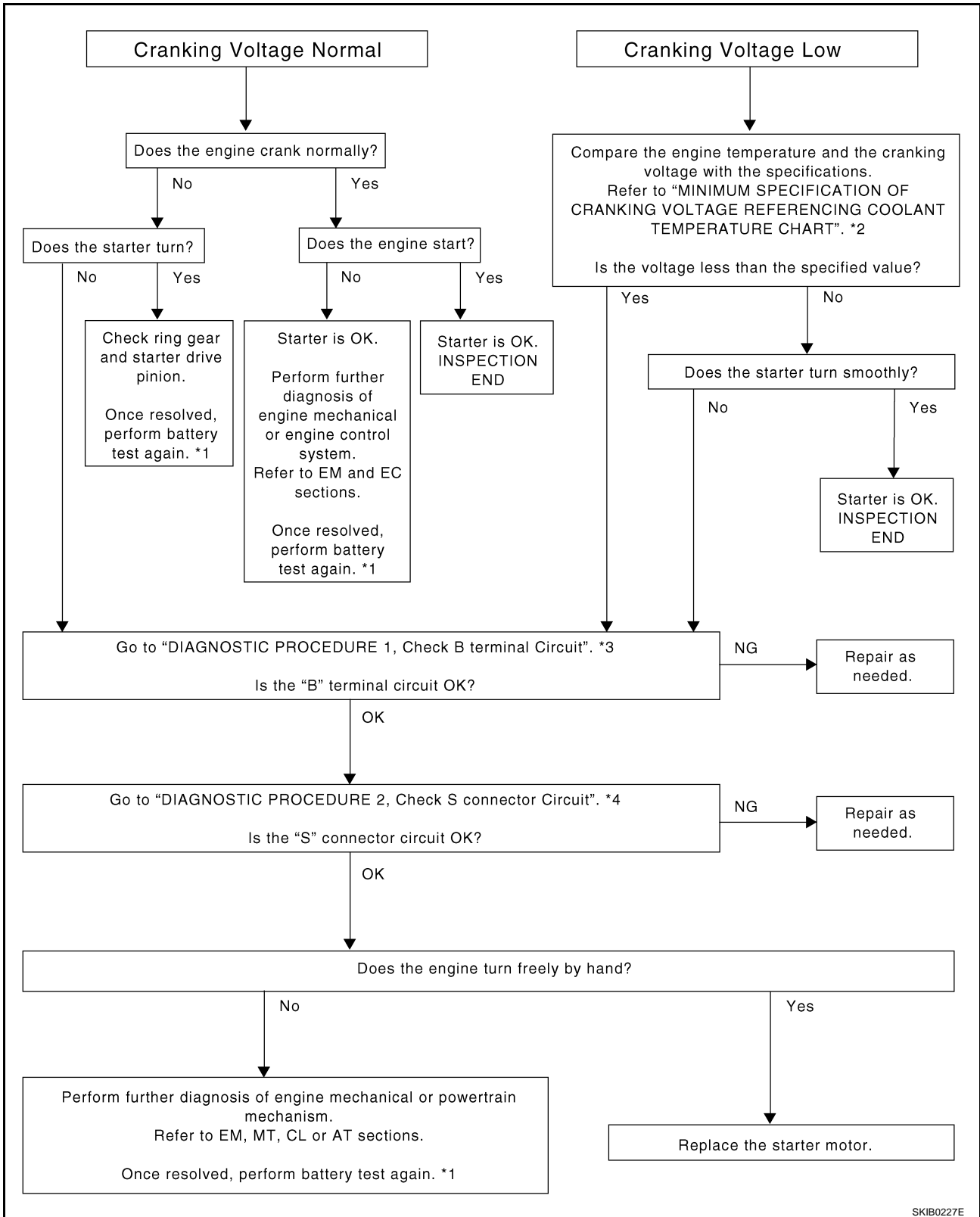

SKIB0227E

*1 [SC-6. "Trouble Diagnosis with Battery/Starting/Charging System Tester"](#)

*2 [SC-14. "MINIMUM SPECIFICATION OF CRANKING VOLTAGE REFERENCING COOLANT TEMPERATURE"](#)

*3 [SC-13. "DIAGNOSTIC PROCEDURE 1"](#)

*4 [SC-14. "DIAGNOSTIC PROCEDURE 2"](#)

STARTING SYSTEM

DIAGNOSTIC PROCEDURE 1

Check "B" Terminal Circuit

1. CHECK POWER SUPPLY FOR STARTER MOTOR "B" TERMINAL

1. Remove the fuel pump fuse.
2. Crank or start the engine (where possible) until the fuel pressure is released.
3. Turn the ignition switch OFF.
4. Make sure that the starter motor B terminal E313 terminal 2 (B/R) connection is clean and tight.
5. Check voltage between starter motor B terminal E313 terminal 2 (B/R) and ground using a digital circuit tester.

Battery voltage should exist.

OK or NG

OK >> GO TO 2.

NG >> Check harness between the battery and the starter motor for open circuit.

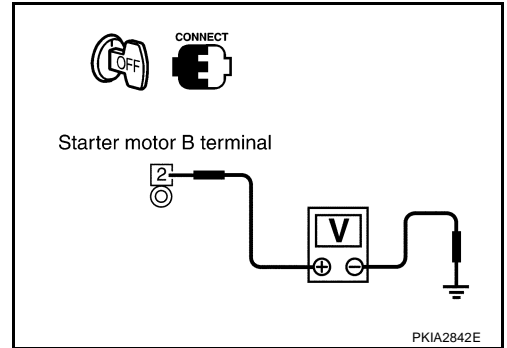

2. CHECK BATTERY CABLE CONNECTION QUALITY (VOLTAGE DROP TEST)

Check voltage between starter motor B terminal E313 terminal 2 (B/R) and battery positive terminal using a digital circuit tester.

**When the ignition switch is in START position,
Voltage: Less than 0.5V**

OK or NG

OK >> GO TO 3.

NG >> Check harness between the battery and the starter motor for poor continuity.

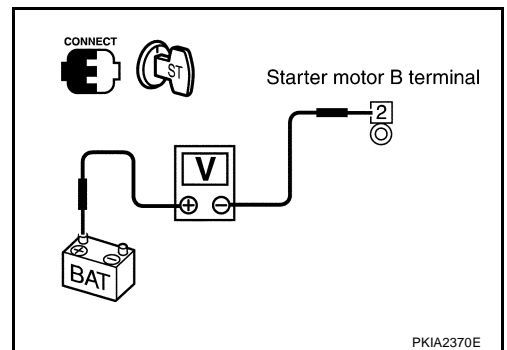

3. CHECK STARTER MOTOR GROUND CIRCUIT (VOLTAGE DROP TEST)

1. Turn ignition switch OFF.
2. Check voltage between starter motor case and battery negative terminal using a digital circuit tester.

**When the ignition switch is in START position,
Voltage: Less than 0.2V**

OK or NG

OK >> Starter motor "B" terminal circuit is OK. Further inspection necessary. Refer to [SC-12, "WORK FLOW"](#).

NG >> Check the starter motor case and ground for poor continuity.

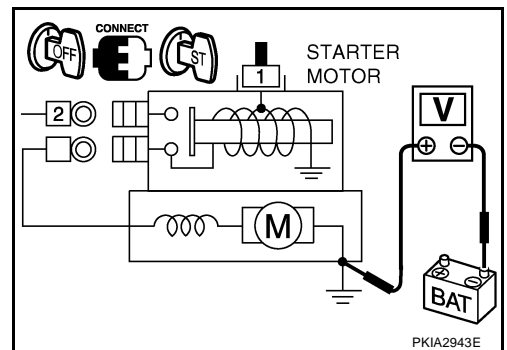

STARTING SYSTEM

DIAGNOSTIC PROCEDURE 2

Check "S" Connector Circuit

1. CHECK POWER SUPPLY FOR STARTER MOTOR "S" CONNECTOR

1. Remove the fuel pump fuse.
2. Crank or start the engine (where possible) until the fuel pressure is released.
3. Turn the ignition switch OFF.
4. Disconnect starter motor connector.
5. Check voltage between starter motor harness connector E312 terminal 1 (B/R) and ground using a digital circuit tester.

**When the ignition switch is in START position,
Battery voltage should exist.**

OK or NG

OK >> GO TO 2.

NG >> **Check the following.**

- 50A fusible link (letter **G** , located in fuse, fusible link and relay box)
- Ignition switch
- Park/neutral position relay
- Harness for open or short

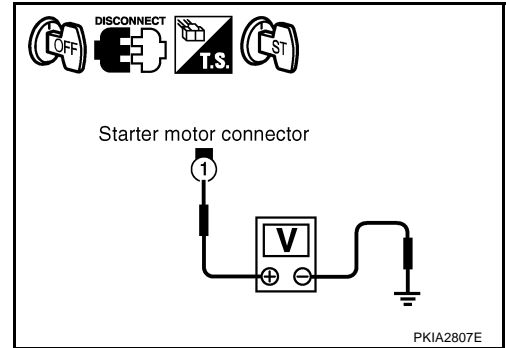

2. CHECK "S" TERMINAL CONNECTION QUALITY (VOLTAGE DROP TEST)

1. Turn ignition switch OFF.
2. Connect starter motor connector.
3. Check voltage between starter motor harness connector E312 terminal 1 (B/R) and battery positive terminal using a digital circuit tester.

**When the ignition switch is in START position,
Voltage: Less than 1V**

OK or NG

OK >> Starter motor "S" connector circuit is OK. Further inspection necessary. Refer to [SC-12, "WORK FLOW"](#) .

NG >> Check harness between the battery and the starter motor "S" connector for poor continuity.

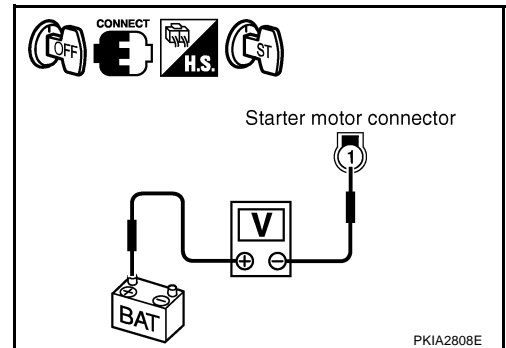

MINIMUM SPECIFICATION OF CRANKING VOLTAGE REFERENCING COOLANT TEMPERATURE

Engine coolant temperature	Voltage V
-30°C to -20°C (-22°F to -4°F)	8.4
-19°C to -10°C (-2°F to 14°F)	8.9
-9°C to 0°C (16°F to 32°F)	9.3
More than 1°C (More than 34°F)	9.7

STARTING SYSTEM

AKS002EN

Removal and Installation

REMOVAL

1. Disconnect negative battery cable.
2. Remove engine undercover, using power tools.
3. Disconnect S connector.
4. Remove B terminal nut.
5. Remove starter motor mounting bolt and nut.
6. Remove engine mounting insulator bottom nuts, and lift up of engine approximately 30mm (1.18in) by using mission jack.
7. Remove starter motor to the direction of under side the vehicle.

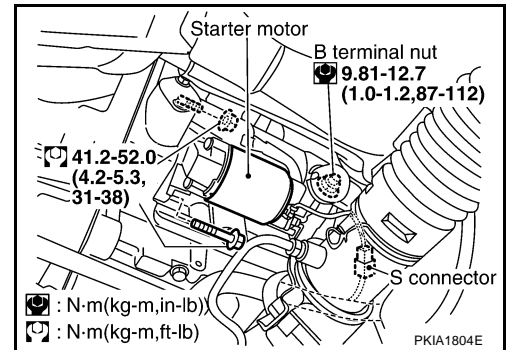

INSTALLATION

Install in the reverse order of removal.

CAUTION:

Be sure to tighten B terminal nut carefully.

A
B
C
D
E
F
G
H
I
J
SC
L
M

STARTING SYSTEM

Disassembly and Assembly

AKS002EO

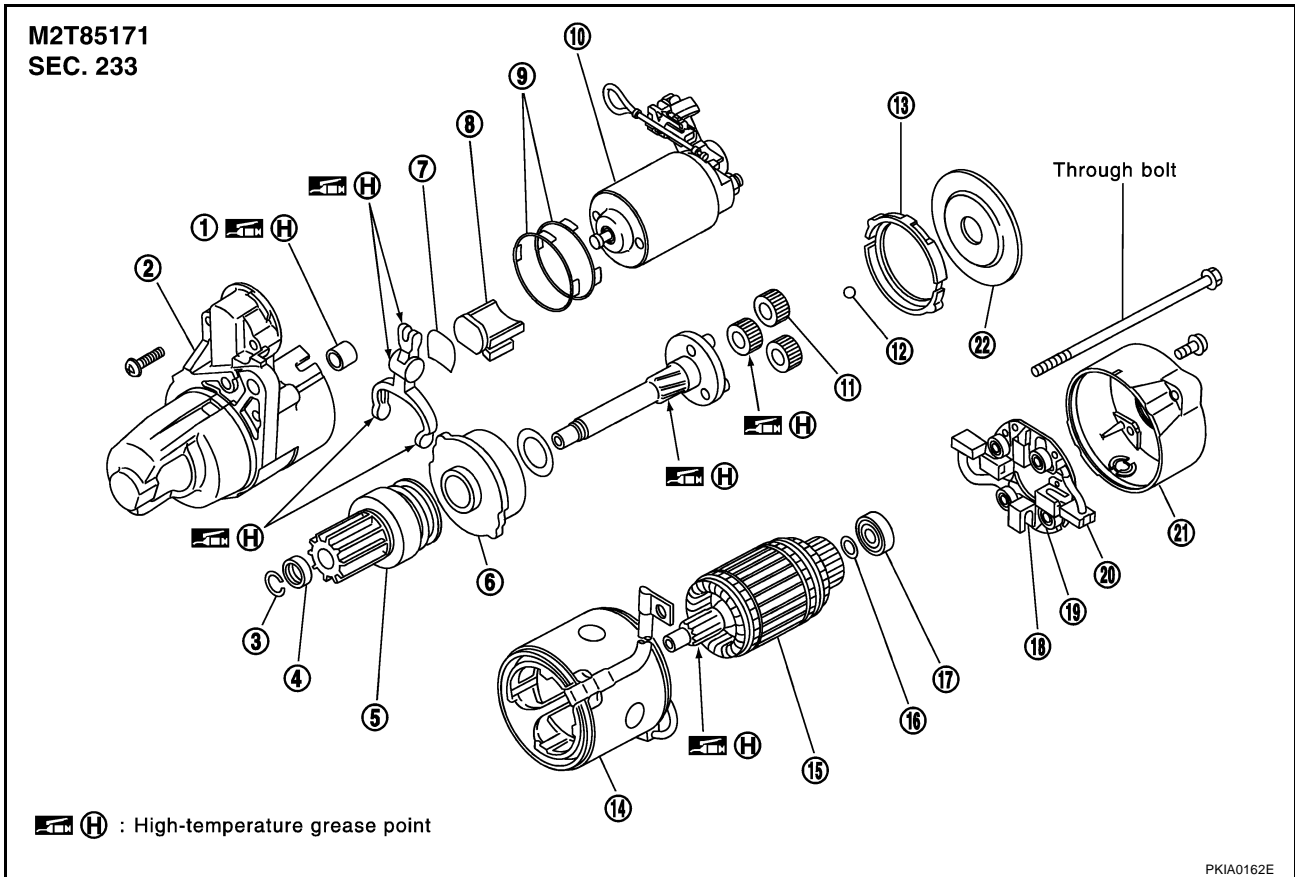

- | | | |
|------------------------------|--------------------|---------------------------|
| 1. Sleeve bearing | 2. Gear case | 3. Stopper clip |
| 4. Pinion stopper | 5. Pinion assembly | 6. Internal gear |
| 7. Plate | 8. Packing | 9. Adjusting plate |
| 10. Magnetic switch assembly | 11. Planetary gear | 12. Ball |
| 13. Packing | 14. Yoke | 15. Armature |
| 16. Washer | 17. Rear bearing | 18. Brush holder assembly |
| 19. Brush spring | 20. Brush (-) | 21. Rear cover |
| 22. Cover | | |

Through bolt:

: 5.6 - 10.4 N·m (0.57 - 1.06 kg-m, 49.5 - 92.0 in-lb)

Inspection After Disassembly PINION/CLUTCH CHECK

AKS002EP

1. Inspect pinion teeth.
 - Replace pinion if teeth are worn or damaged. (Also check condition of ring gear teeth.)
2. Inspect reduction gear teeth.
 - Replace reduction gear if teeth are worn or damaged. (Also check condition of armature shaft gear teeth.)
3. Check to see if pinion locks in one direction and rotates smoothly in the opposite direction.
 - If it locks or rotates in both directions, or unusual resistance is evident, replace.

CHARGING SYSTEM

CHARGING SYSTEM

PFP:00011

System Description

AKS002EF

The alternator provides DC voltage to operate the vehicle's electrical system and to keep the battery charged. The voltage output is controlled by the IC regulator.

Power is supplied at all times to alternator terminal 4 (S) through:

- 15A fuse [No. 56, located in the fuse, fusible link and relay block (J/B)].

Terminal B supplies power to charge the battery and operate the vehicle's electrical system. Output voltage is controlled by the IC regulator at terminal 4 (S) detecting the input voltage.

The alternator is grounded to the engine block.

With the ignition switch in the ON or START position, power is supplied

- 10A fuse [No. 9, located in the fuse block (J/B) No.1]
- to combination meter terminals 40 and 42 for the charge warning lamp.

Ground is supplied to combination meter terminal 64 through alternator terminal 3 (L). With power and ground supplied, the charge warning lamp will illuminate. When the alternator is providing sufficient voltage with the engine running, the ground is opened and the charge warning lamp will go off.

If the charge warning lamp illuminates with the engine running, a malfunction is indicated.

A

B

C

D

E

F

G

H

I

J

SC

L

M

CHARGING SYSTEM

Trouble Diagnosis with Battery/Starting/Charging System Tester

AKS002EH

NOTE:

To ensure a complete and thorough diagnosis, the battery, starter and alternator test segments must be done as a set from start to finish.

1. Turn off all loads on the vehicle electrical system.
2. Perform battery and starting system test with Battery/Starting/Charging system tester.
3. Press "ENTER" to begin the charging system test.
4. Start engine.

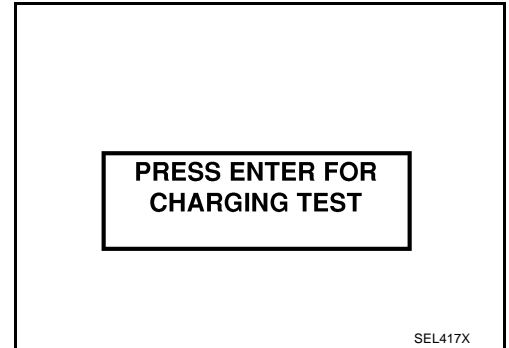

5. Press "ENTER" until "LOADS OFF REV ENGINE 5 SEC" is displayed.
6. Raise and hold the engine speed at 1,500 to 2,000 rpm for about 5 seconds, then return to the engine to idle. Once the increase in engine rpm is detected, press "ENTER" to continue.

NOTE:

- If after 30 seconds an increase in engine idle speed is not detected, "RPM NOT DETECTED" will display.
- Some engines may have a higher idle initially after starting, particularly when the engine is cold. The tester may detect this without any other action being taken. If this occurs, continue on with the testing process. The final results will not be affected.

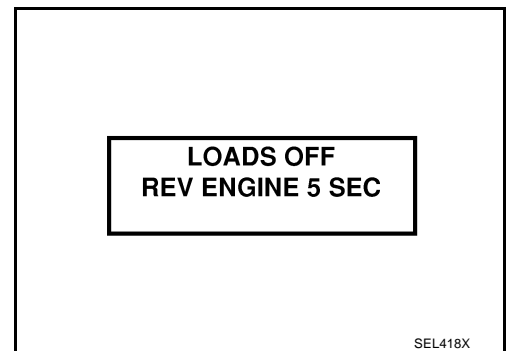

7. The tester now checks the engine at idle and performs the DIODE/RIPPLE check.
8. When complete, the tester will prompt you to turn on the following electrical loads.
 - Heater fan set to highest speed. Do not run the A/C or windshield defroster.
 - Headlamp high beam
 - Rear window defogger

NOTE:

Do not run the windshield wipers or any other cyclical loads.

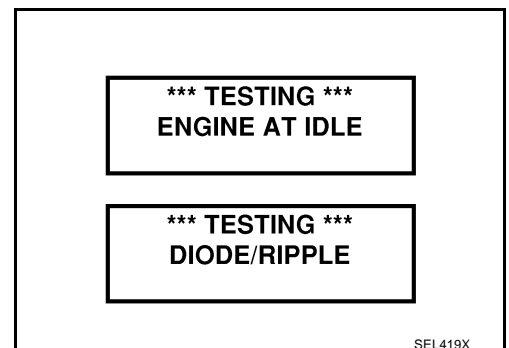

9. Press "ENTER" to continue.

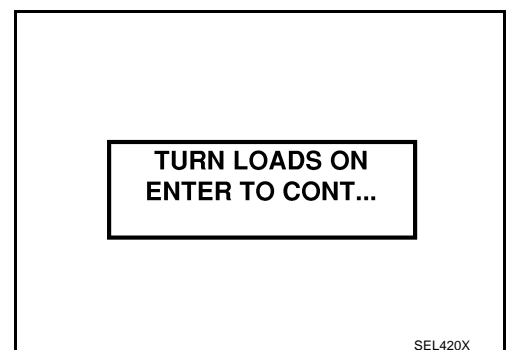

A
B
C
D
E
F
G
H
I
J
SC
L
M

CHARGING SYSTEM

10. Raise and hold the engine speed at 1,500 to 2,000 rpm for about 5 seconds, then return the engine to idle. Once the increase in engine rpm is detected, press "ENTER" to continue.

NOTE:

If after 30 seconds an increase in engine idle speed is not detected, "RPM NOT DETECTED" will be displayed. Press "ENTER" to restart the test.

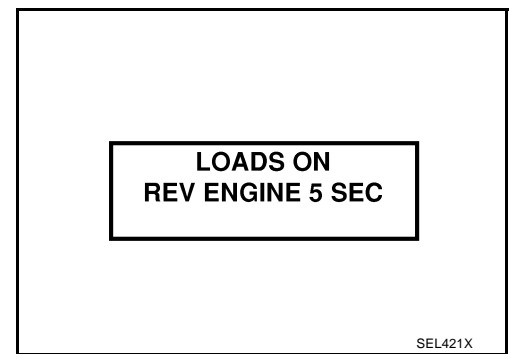

11. Diagnostic result is displayed on the tester. Refer to [SC-20, "DIAGNOSTIC RESULT ITEM CHART"](#) .

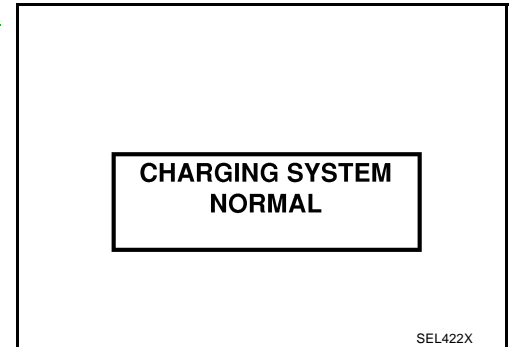

12. Press "ENTER" then test output code is displayed. Record the test output code on the repair order.
 13. Toggle back to the "DIAGNOSTIC SCREEN" for test results.

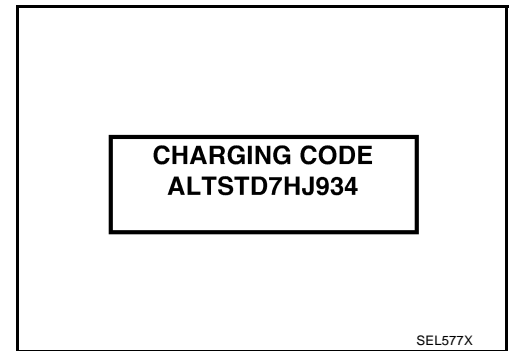

DIAGNOSTIC RESULT ITEM CHART

Diagnostic item	Service procedure
CHARGING SYSTEM NORMAL	Charging system is normal and will also show DIODE RIPPLE test result.
NO CHARGING VOLTAGE	Go to SC-21, "WORK FLOW" .
LOW CHARGING VOLTAGE	Go to SC-21, "WORK FLOW" .
HIGH CHARGING VOLTAGE	Go to SC-21, "WORK FLOW" .
DIODE RIPPLE NORMAL	Diode ripple is OK and will also show CHARGING VOLTAGE test result.
EXCESS RIPPLE DETECTED	Replace the alternator. Perform "DIODE RIPPLE" test again using Battery/Starting/Charging system tester to confirm repair.
DIODE RIPPLE NOT DETECTED	Go to SC-21, "WORK FLOW" .

CHARGING SYSTEM

WORK FLOW

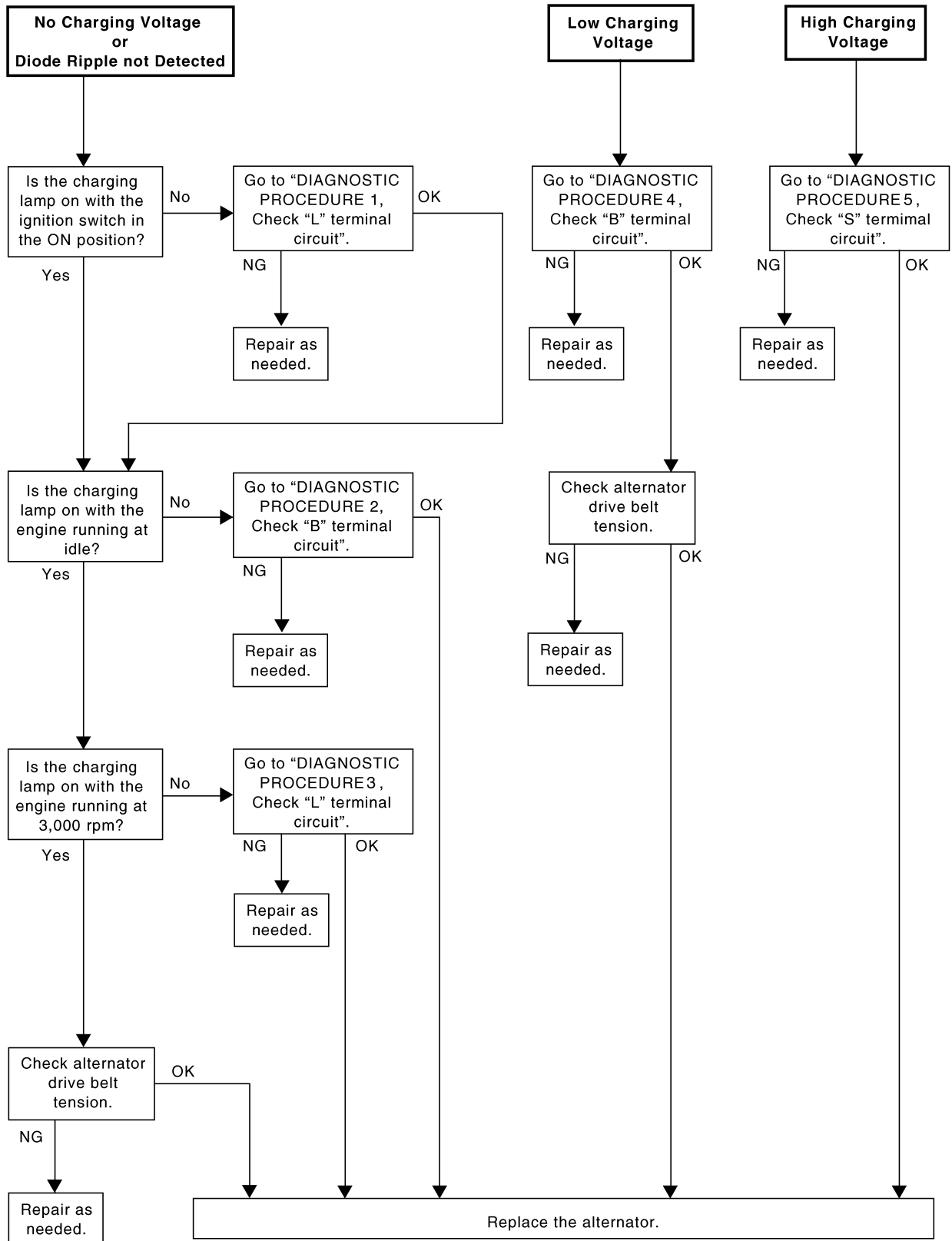

A
B
C
D
E
F
G
H
I
J
SC
L
M

PKIA2226E

CHARGING SYSTEM

DIAGNOSTIC PROCEDURE 1

Check "L" Terminal Circuit

1. CHECK "L" TERMINAL CONNECTION

1. Turn ignition switch OFF.
2. Check to see if "L" terminal is clean and tight.

OK or NG

OK >> GO TO 2.

NG >> Repair "L" terminal connection. Confirm repair by performing complete Battery/Starting/Charging system test.

2. CHECK "L" TERMINAL CIRCUIT

1. Disconnect alternator connector.
2. Apply ground to alternator harness connector E310 terminal 3 (W/R) with the ignition switch in the ON position.

CHARGE lamp should light up.

OK or NG

OK >> GO TO [SC-21, "WORK FLOW"](#).

NG >> **Check the following.**

- 10A fuse [No. 9, located in fuse block (J/B) No.1]
- CHARGE lamp
- Harness for open or short between combination meter and fuse
- Harness for open or short between combination meter and alternator

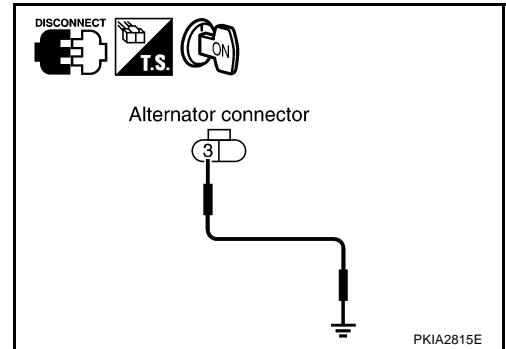

CHARGING SYSTEM

DIAGNOSTIC PROCEDURE 2

Check "B" Terminal Circuit

1. CHECK "B" TERMINAL CONNECTION

1. Turn ignition switch OFF.
2. Check to see if "B" terminal is clean and tight.

OK or NG

- OK >> GO TO 2. Confirm repair by performing complete Battery/Starting/Charging system test.
NG >> Repair "B" terminal connection.

2. CHECK ALTERNATOR "B" TERMINAL CIRCUIT

Check voltage between alternator B terminal E309 terminal 1 (B/R) and ground using a digital circuit tester.

Battery voltage should exist.

OK or NG

- OK >> GO TO 3.
NG >> Check harness for open or short between alternator and fusible link.

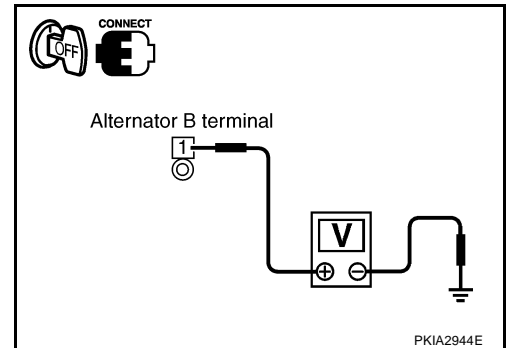

3. CHECK "B" TERMINAL CONNECTION QUALITY (VOLTAGE DROP TEST)

1. Start the engine.
2. When the engine running at idle and warm, check voltage between alternator B terminal E309 terminal 1 (B/R) and battery positive terminal using a digital tester.

Voltage: Less than 0.2 V

OK or NG

- OK >> Replace the alternator. Confirm repair by performing complete Battery/Starting/Charging system test.
NG >> Check harness between the battery and the alternator for poor continuity.

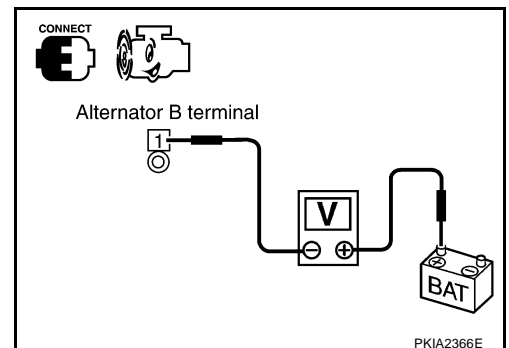

A
B
C
D
E
F
G
H
I
J
SC
L
M

CHARGING SYSTEM

DIAGNOSTIC PROCEDURE 3

Check "L" Terminal Circuit

1. CHECK "L" TERMINAL CONNECTION

1. Turn ignition switch OFF.
2. Check to see if "L" terminal is clean and tight.

OK or NG

OK >> GO TO 2.

NG >> Repair "L" terminal connection. Confirm repair by performing complete Battery/Starting/Charging system test.

2. CHECK "L" TERMINAL CIRCUIT

1. Disconnect alternator connector.
2. Apply ground to alternator harness connector E310 terminal 3 (W/R) with the ignition switch in the ON position.

CHARGE lamp should light up.

OK or NG

OK >> Replace the alternator. Confirm repair by performing complete Battery/Starting/Charging system test.

NG >> **Check the following.**

- 10A fuse [No. 9, located in fuse block (J/B) No.1]
- CHARGE lamp
- Harness for open or short between combination meter and fuse
- Harness for open or short between combination meter and alternator

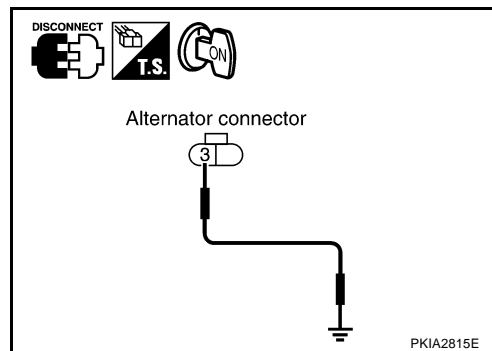

CHARGING SYSTEM

DIAGNOSTIC PROCEDURE 4

Check "B" Terminal Circuit

1. CHECK "B" TERMINAL CONNECTION

1. Turn ignition switch OFF.
2. Check to see if "B" terminal is clean and tight.

OK or NG

- OK >> GO TO 2. Confirm repair by performing complete Battery/Starting/Charging system test.
NG >> Repair "B" terminal connection.

2. CHECK ALTERNATOR "B" TERMINAL CIRCUIT

Check voltage between alternator B terminal E309 terminal 1 (B/R) and ground using a digital circuit tester.

Battery voltage should exist.

OK or NG

- OK >> GO TO 3.
NG >> Check harness for open or short between alternator and fusible link.

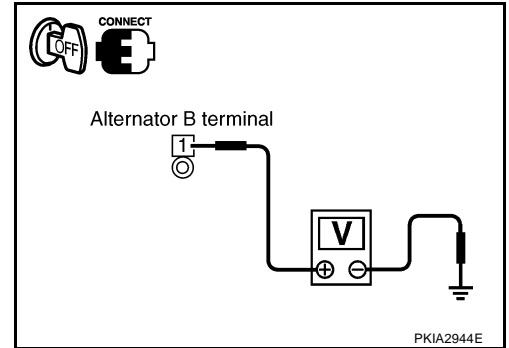

3. CHECK "B" TERMINAL CONNECTION QUALITY (VOLTAGE DROP TEST)

1. Start the engine.
2. When the engine running at idle and warm, check voltage between alternator B terminal E309 terminal 1 (B/R) and battery positive terminal using a digital circuit tester.

Voltage: Less than 0.2 V

OK or NG

- OK >> GO TO 4.
NG >> Check harness between the battery and the alternator for poor continuity.

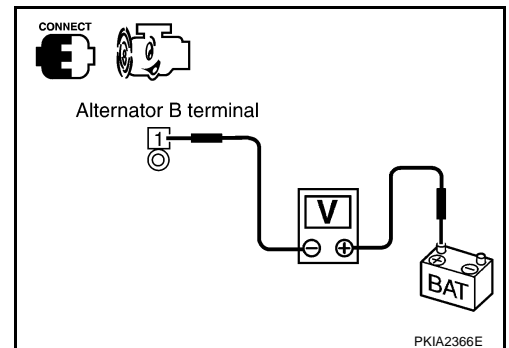

4. CHECK ALTERNATOR DRIVE BELT TENSION

1. Turn ignition switch OFF.
2. Check alternator drive belt tension. Refer to [EM-13, "Checking Drive Belts"](#) in "ENGINE MECHANICAL (EM)" section.

Does drive belt tension normal?

YES or NO

- YES >> Replace the alternator. Confirm repair by performing complete Battery/Starting/Charging system test.
NO >> Readjust belt tension. Refer to [EM-13, "Tension Adjustment"](#) in "ENGINE MECHANICAL (EM)" section.

CHARGING SYSTEM

DIAGNOSTIC PROCEDURE 5

Check "S" Terminal Circuit

1. CHECK "S" TERMINAL CONNECTION

1. Turn ignition switch OFF.
2. Check to see if "S" terminal is clean and tight.

OK or NG

OK >> GO TO 2.

NG >> Repair "S" terminal connection. Confirm repair by performing complete Battery/Starting/Charging system test.

2. CHECK ALTERNATOR "S" TERMINAL CIRCUIT

Check voltage between alternator harness connector E310 terminal 4 (Y/B) and ground using a digital circuit tester.

Battery voltage should exist.

OK or NG

OK >> GO TO 3.

NG >> **Check the following.**

- 15A fuse [No. 56, located in fuse, fusible link and relay block (J/B)]
- Harness for open or short between alternator and fuse

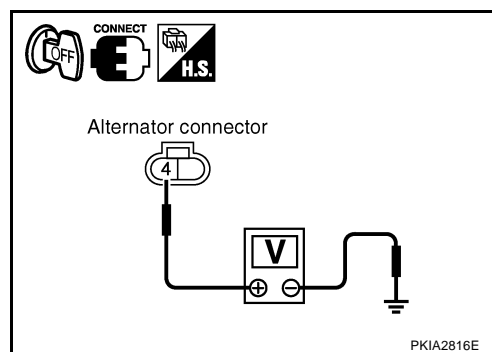

3. CHECK "S" TERMINAL CONNECTION QUALITY (VOLTAGE DROP TEST)

1. Start the engine.
2. When the engine running at idle and warm, check voltage between alternator connector E310 terminal 4 (Y/B) and battery positive terminal using a digital circuit tester.

Voltage: Less than 0.2 V

OK or NG

OK >> Replace the alternator. Confirm repair by performing complete Battery/Starting/Charging system test.

NG >> Check harness between the battery and the alternator for poor continuity.

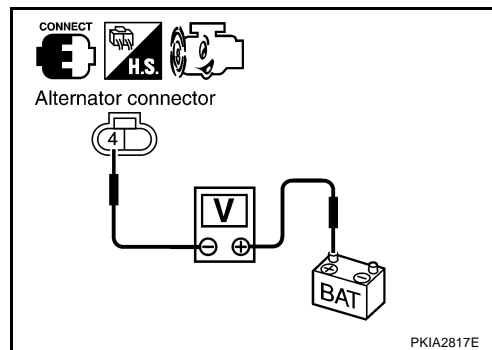

MALFUNCTION INDICATOR

The IC regulator warning function activates to illuminate "CHARGE" warning lamp, if any of the following symptoms occur while alternator is operating:

- Excessive voltage is produced.
- No voltage is produced.

CHARGING SYSTEM

Removal and Installation

AKS002E1

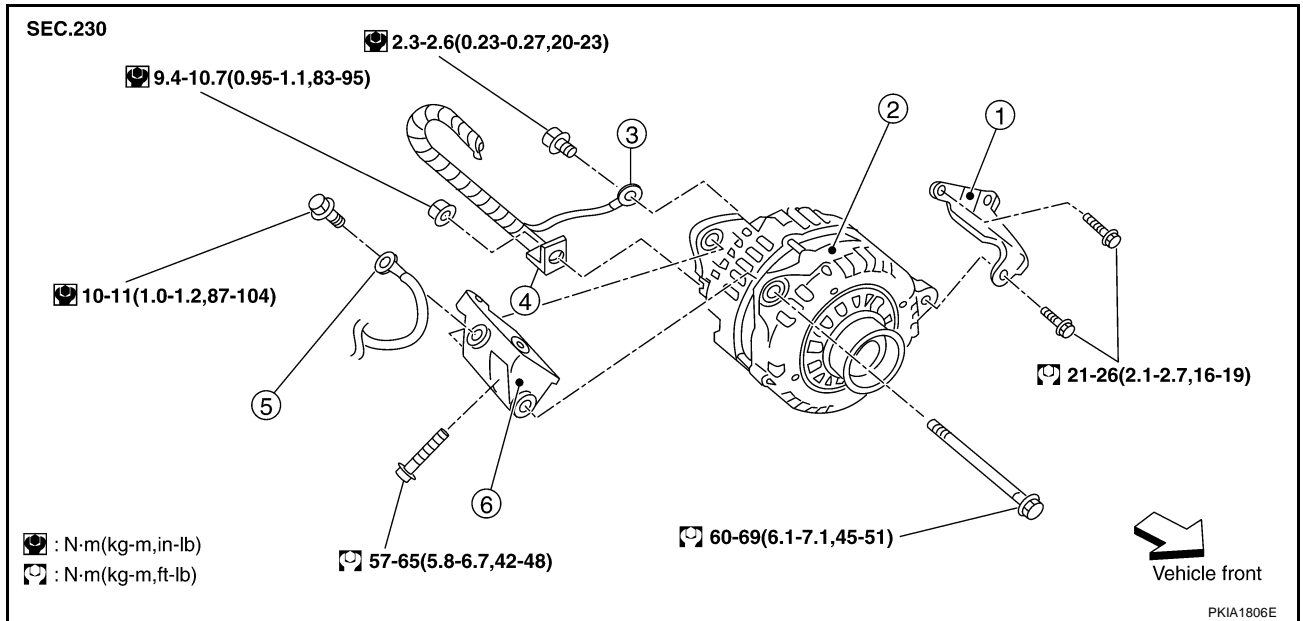

- | | | |
|--------------------------|---------------------------|------------------------------|
| 1. Alternator stay | 2. Alternator | 3. Alternator ground harness |
| 4. Alternator B terminal | 5. Battery ground harness | 6. Alternator bracket |

REMOVAL

- Remove battery. Refer to [SC-8, "Removal and Installation"](#).
- Remove air intake duct. Refer to [EM-16, "AIR CLEANER AND AIR DUCT"](#) in "ENGINE MECHANICAL (EM)" section.
- Remove alternator, water pump and A/C compressor belt. Refer to [EM-13, "Removal and Installation"](#) "ENGINE MECHANICAL (EM)" section.
- Remove power steering hose clamp mounting bolt.
- Remove alternator stay mounting bolts and alternator stay.
- Remove radiator reservoir tank and radiator reservoir tank bracket. Refer to [CO-12, "RADIATOR"](#) in "ENGINE COOLING SYSTEM (CO)" section.
- Remove battery ground harness mounting bolt.
- Remove engine room harness clip.

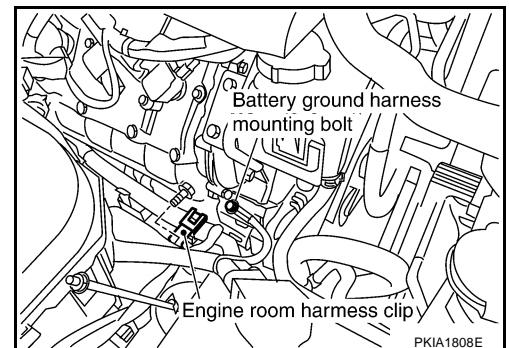
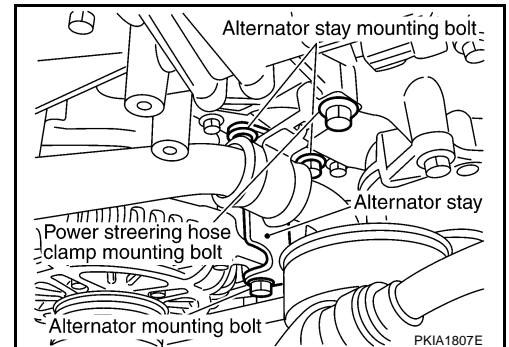

CHARGING SYSTEM

9. Remove alternator mounting bolt.
10. Remove alternator bracket mounting bolts and alternator bracket.
11. Remove B terminal nut.
12. Disconnect alternator connector.
13. Remove alternator ground harness mounting bolt.

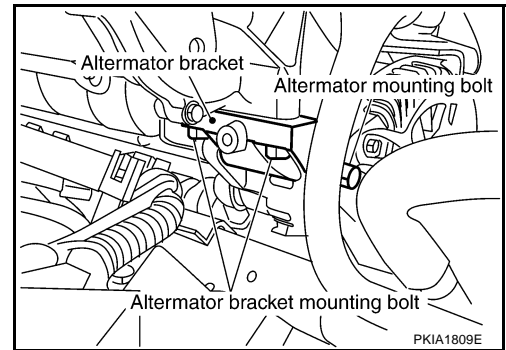

14. Remove power steering oil reservoir tank mounting bolts, then slide power steering oil reservoir tank.
15. Remove alternator assembly from vehicle upper side.

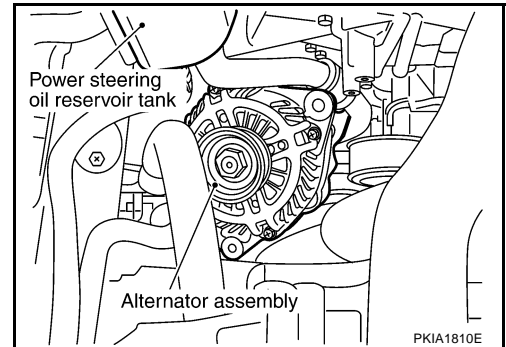

INSTALLATION

Install in the reverse order of removal, taking care of the following point.

- Install alternator, and check tension of belt. Refer to [MA-12, "Checking Drive Belts"](#) in "ENGINE MECHANICAL (EM)" section.

CAUTION:

Be sure to tighten B terminal mounting nut carefully.

CHARGING SYSTEM

Disassembly and Assembly

AKS002EJ

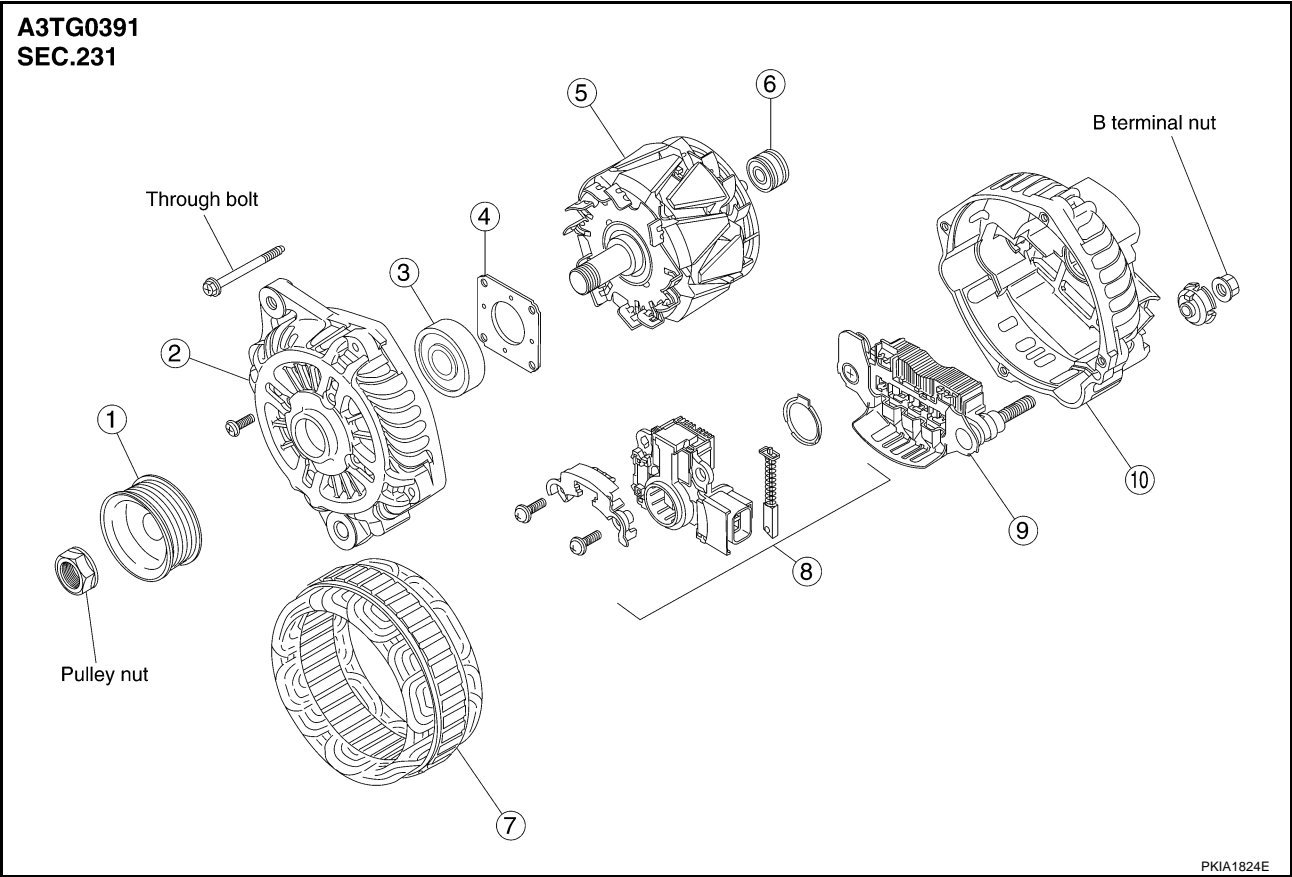

- | | | |
|----------------|----------------------------------|-------------------|
| 1. Pulley | 2. Front cover | 3. Front bearing |
| 4. Retainer | 5. Rotor | 6. Rear bearing |
| 7. Stator | 8. IC voltage regulator assembly | 9. Diode assembly |
| 10. Rear cover | | |

Through bolt:

: 3.5 - 5.3 N·m (0.36 - 0.54 kg-m, 31 - 47 in-lb)

Pulley nut:

: 99 - 137 N·m (10.1 - 14.0 kg-m, 73 - 101 ft-lb)

A
B
C
D
E
F
G
H
I
J
SC
L
M

SERVICE DATA AND SPECIFICATIONS (SDS)

SERVICE DATA AND SPECIFICATIONS (SDS)

PFP:00030

Battery

AKS002EO

Type	80D23R
Capacity	12V - 52AH
Cold cranking current (For reference value)	582A

Starter

AKS002ER

Type		M2T85171
		MITSUBISHI make
		Reduction gear type
System voltage		12V
No-load	Terminal voltage	11V
	Current	Less than 145A
	Revolution	More than 3,300 rpm
Minimum diameter of commutator		31.4 mm (1.236 in)
Minimum length of brush		11.0 mm (0.433 in)
Brush spring tension		30.9 - 37.7 N (3.15 - 3.85 kg, 6.95 - 8.47 lb)
Clearance between bearing metal and armature shaft		Less than 0.2 mm (0.008 in)
Clearance between pinion front edge and pinion stopper		0.5 - 2.0 mm (0.020 - 0.079 in)

Alternator

AKS002ES

Type		A3TG0391
		MITSUBISHI make
Nominal rating		12V - 110A
Ground polarity		Negative
Minimum revolution under no-load (When 13.5 V is applied)		Less than 1,000 rpm
Hot output current (When 13.5 V is applied)		More than 31A / 1,300 rpm More than 90A / 2,500 rpm More than 102A / 5,000 rpm
Regulated output voltage		14.1 - 14.7V
Minimum length of brush		More than 5.00 mm (0.197 in)
Brush spring pressure		4.8 - 6.1 N (490 - 610 g, 17.28 - 21.51 oz)
Slip ring minimum outer diameter		More than 22.1 mm (0.870 in)
Rotor (Field coil) resistance		1.7 - 2.1 Ω