

SECTION **PR**  
PROPELLER SHAFT

A  
B  
C

PR

CONTENTS

E

<b>PREPARATION</b> .....	2	APPEARANCE AND NOISE INSPECTION	4	F
Commercial Service Tools .....	2	Removal and Installation .....	5	
<b>NOISE, VIBRATION AND HARSHNESS (NVH)</b>		REMOVAL .....	5	
<b>TROUBLESHOOTING</b> .....	3	INSPECTION .....	6	G
NVH Troubleshooting Chart .....	3	INSTALLATION .....	6	
<b>REAR PROPELLER SHAFT</b> .....	4	<b>SERVICE DATA</b> .....	8	
On-Vehicle Service .....	4	General Specifications .....	8	H
PROPELLER SHAFT VIBRATION .....	4	Propeller Shaft Runout Limit .....	8	

I

J

K

L

M

# PREPARATION

---

## PREPARATION

PFP:00002

### Commercial Service Tools

---

ADS000AV

Power tool

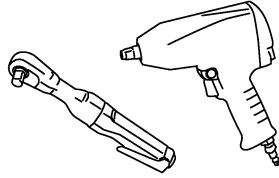

PBIC0190E

---

# NOISE, VIBRATION AND HARSHNESS (NVH) TROUBLESHOOTING

## NOISE, VIBRATION AND HARSHNESS (NVH) TROUBLESHOOTING

PPF:00003

### NVH Troubleshooting Chart

ADS0001V

Use the chart below to help you find the cause of the symptom. If necessary, repair or replace these parts.

Symptom		Possible cause and SUSPECTED PARTS													
		Uneven rotation torque	Center bearing improper installation	Excessive center bearing axial end play	Center bearing mounting (insulator) cracks, damage or deterioration	Excessive joint angle	Rotation imbalance	Excessive runout	DIFFERENTIAL	AXLE AND SUSPENSION	TIRES	ROAD WHEEL	DRIVE SHAFT	BRAKES	STEERING
PROPELLER SHAFT	Noise	x	x	x	x	x	x	x	x	x	x	x	x	x	x
	Shake		x			x				x	x	x	x	x	x
	Vibration	x	x	x	x	x	x	x	x	x		x			x
Reference page		—	Refer to <a href="#">PR-4</a> for details.	—	—	—	Refer to <a href="#">PR-4</a> for details.	—	Refer to NVH in RFD section for details.	Refer to NVH in FAX, RAX, FSU, and RSU section for details.	NVH in WT section for details.	NVH in WT section for details.			

x: Applicable

A  
B  
C  
**PR**  
E  
F  
G  
H  
I  
J  
K  
L  
M

# REAR PROPELLER SHAFT

## REAR PROPELLER SHAFT

PFP:37000

### On-Vehicle Service PROPELLER SHAFT VIBRATION

ADS0001W

#### CAUTION:

If vibration is present at high speed, check mounting between propeller shaft and companion flange. If vibration is present at high speed, inspect propeller shaft runout first.

1. Measure propeller shaft runout at several points by rotating final drive companion flange with hands.

**Runout limit :0.6 mm (0.024 in) or less**

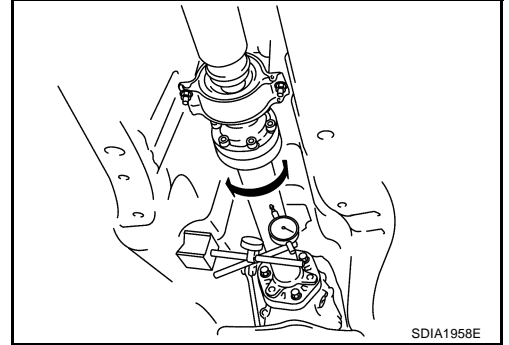

#### Propeller shaft runout measuring points:

Unit: mm (in)

Distance	A	B	C
A/T	162 (6.38)	160 (6.30)	185 (7.28)

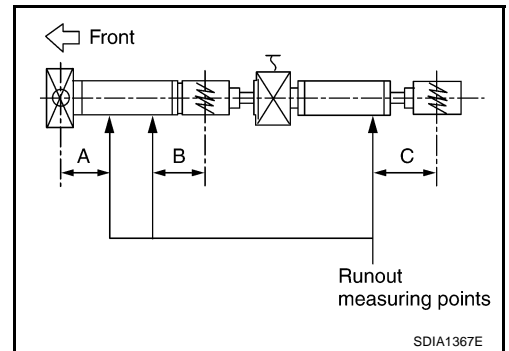

2. If runout still exceeds specifications, disconnect propeller shaft at final drive companion flange: then rotate companion flange 60, 120, 180, 240, 300 degrees and reconnect propeller shaft.
3. Check runout again. If runout still exceeds specifications, replace propeller shaft assembly.
4. Perform driving test to check.
5. If the runout exceeds the service limit, do the following:
  - Remove the propeller shaft from the final drive companion flange.
  - Turn the propeller shaft 60, 120, 180, 240, 300 degrees and reinstall the propeller shaft to the companion flange, then measure the runout again.
  - If the runout still exceeds the service limit, replace the propeller shaft assembly.
  - Check the vibration by driving the vehicle.

#### APPEARANCE AND NOISE INSPECTION

- Inspect propeller shaft tube surface for dents or cracks. If damaged, replace propeller shaft assembly.
- If center bearing is noisy or damaged, replace propeller shaft assembly.

# REAR PROPELLER SHAFT

## Removal and Installation

ADS0001X

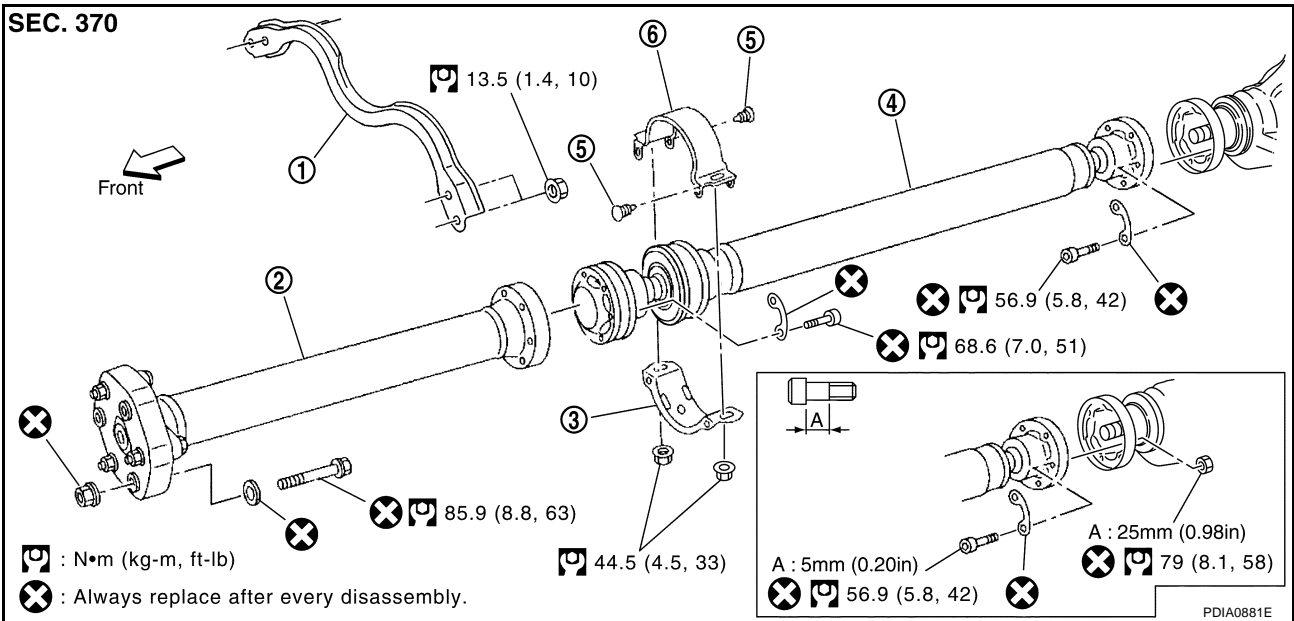

- |                        |                        |  |
|------------------------|------------------------|--|
| 1. Floor reinforcement | 2. 1st propeller shaft | 3. Center bearing mounting bracket (Lower) |
| 4. 2nd propeller shaft | 5. Clip                | 6. Center bearing mounting bracket (Upper) |

### REMOVAL

1. Move A/T select lever to N range position and release the parking brake.
2. Remove exhaust front tube and center muffler. Refer to [EX-3, "EXHAUST SYSTEM"](#) for details.
3. Remove floor reinforcement.

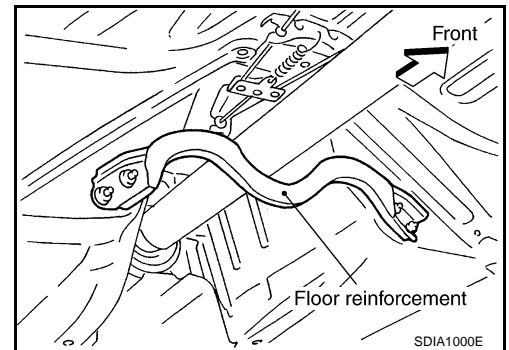

4. Loosen center bearing bracket fixing nuts with power tool.

**CAUTION:**  
Do not remove center bearing bracket fixing nuts.

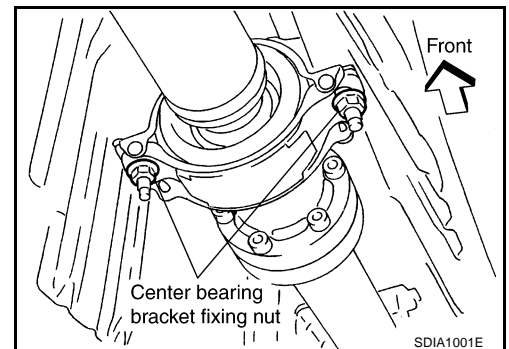

## REAR PROPELLER SHAFT

5. Put matching marks on flange and rear propeller shaft. (A/T side and final drive side)
6. Remove propeller shaft fixing bolts. (A/T side and final drive side)
7. Remove center bearing bracket fixing nuts.
8. Remove propeller shaft from vehicle.

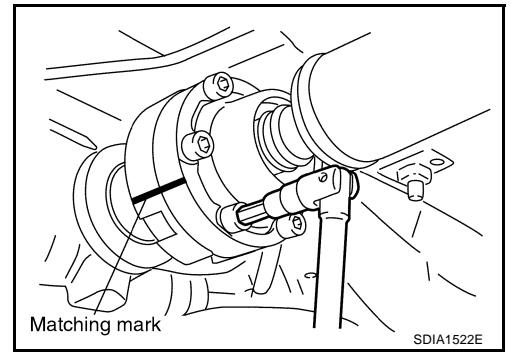

### INSPECTION

- Inspect propeller shaft runout. If runout exceeds specifications, replace propeller shaft assembly.

**Runout limit : 0.6 mm (0.024 in) or less**

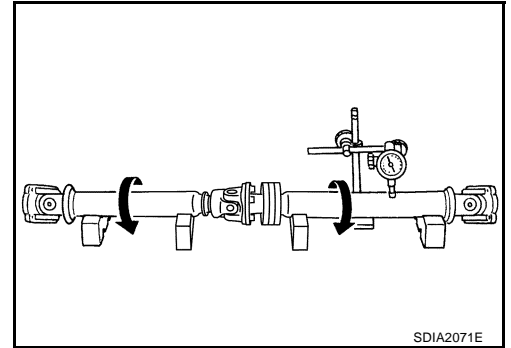

### Propeller shaft runout measuring points:

Unit: mm (in)

Distance	A	B	C
A/T	162 (6.38)	160 (6.30)	185 (7.28)

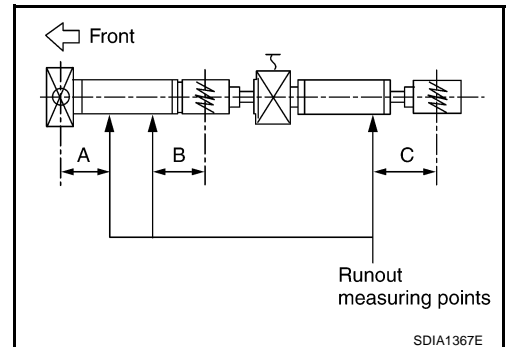

### INSTALLATION

1. Paying attention to following items, install in the reverse order of removal.
  - a. Install the propeller shaft onto the rear final drive companion flange while aligning the matching marks that are marked during removal.

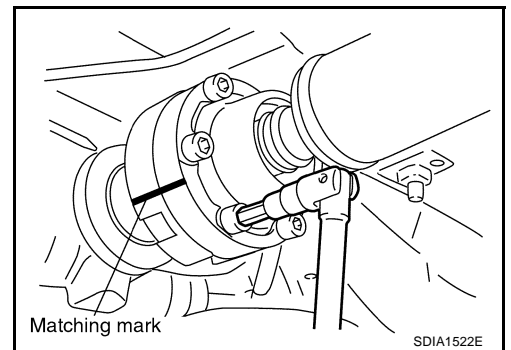

## REAR PROPELLER SHAFT

- b. Adjust position of the bearing cushion so as not to apply thrust play to the center bearing insulator.
- c. Position the bearing cushion overlap as shown in the figure.
- d. Install the center bearing bracket (upper) with its arrow mark facing forward.
- e. Tighten the center bearing mounting bracket (upper) fixing nuts to specified torque.

**CAUTION:**

**Do not reuse the nuts. Always replace the nuts with a new one.**

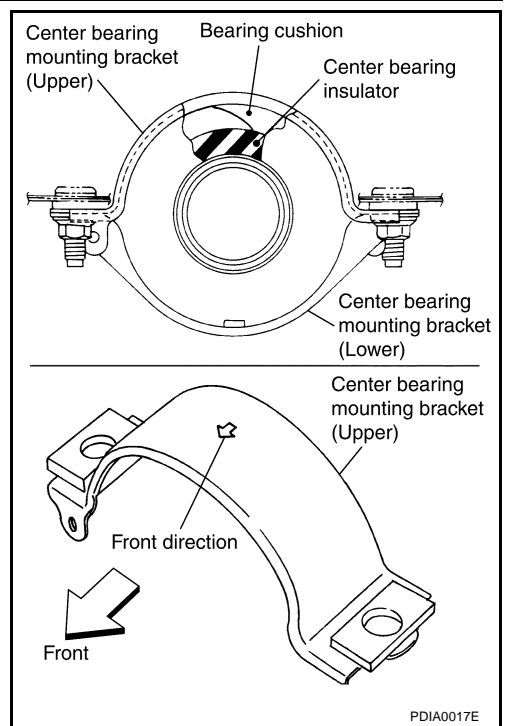

2. If companion flange has been removed, put new alignment matching mark B on it. Then, reassemble using the following procedure. Perform these steps when either of final drive and shaft is replaced with a new one.

- a. Erase original mark B from companion flange with suitable solvent.
- b. Measure companion flange vertical runout.
- c. Determine the position where maximum runout is read on dial indicator. Put mark (shown by B in figure) on flange perimeter corresponding to maximum runout position.

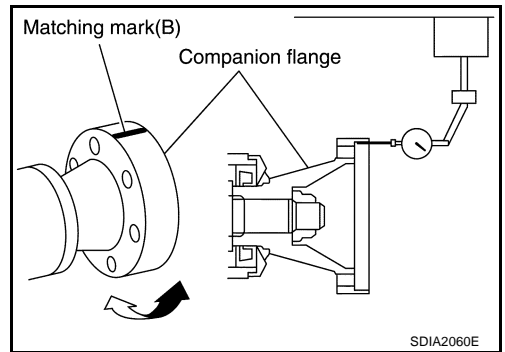

3. If the propeller shaft or final drive has been replaced, connect the propeller shaft and final drive as follows:

**NOTE:**

Avoid damaging the rebro joint boot, protect it with a shop towel or equivalent.

- Install the propeller shaft while aligning its matching mark A with the mark C on the joint as close as possible.
- Tighten the joint bolts/nuts to specified torque.

**CAUTION:**

**Do not reuse the bolts, and washers. Always replace them with new ones.**

- After installation, check the vibration by driving the vehicle. If the vibration is present, remove the propeller shaft from the final drive companion flange.
- Turn the propeller shaft 60, 120, 180, 240 or 300 degrees and reinstall the propeller shaft to the companion flange, then measure the runout again by driving the vehicle on each angle position.

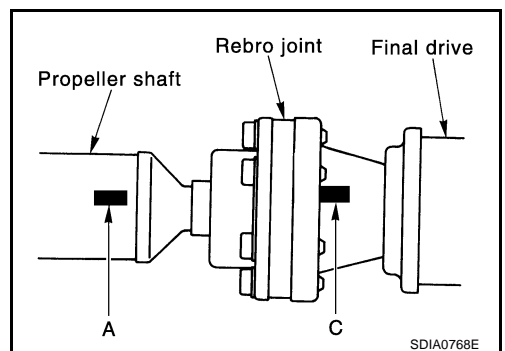

A  
B  
C  
PR  
E  
F  
G  
H  
I  
J  
K  
L  
M

# SERVICE DATA

## SERVICE DATA

PFP:00030

### General Specifications

ADS000CC

Applied model	VK45DE	
	A/T	
Propeller shaft model	3F-R-2VL107	
Number of joints	3	
Coupling method with transmission	Flange type	
Type of journal bearings	Shell type (Non-disassembly type)	
Distance between yokes	1st	115 mm (4.53 in)
	2nd	94 mm (3.70 in)
Shaft length (Joint to joint)	1st	553 mm (21.77 in)
	2nd	896 mm (35.28 in)
Shaft outer diameter	1st	63.5 mm (2.50 in)
	2nd	63.5 mm (2.50 in)

### Propeller Shaft Runout Limit

ADS0001Z

Model	3F-R-2VL107
Propeller shaft runout limit	0.6 mm (0.024 in) or less