

SECTION **AV**

AUDIO, VISUAL, NAVIGATION & TELEPHONE SYSTEM

CONTENTS

PRECAUTIONS	3	Removal and Installation of CD Auto Changer	30	A
Precautions for Supplemental Restraint System (SRS) "AIR BAG" and "SEAT BELT PRE-TENSIONER"	3	REMOVAL	30	B
Wiring Diagrams and Trouble Diagnosis	3	INSTALLATION	30	C
PREPARATION	4	Removal and Installation of Door Speaker	30	D
Commercial Service Tools	4	REMOVAL	30	E
AUDIO	5	INSTALLATION	30	F
System Description	5	Removal and Installation of Instrument Panel Speaker	31	G
AUDIO SYSTEM	5	REMOVAL	32	H
AV COMMUNICATION LINE	5	INSTALLATION	32	I
AUDIOPILOT™ SYSTEM	5	Removal and Installation of Woofer	32	J
Component Parts Location	6	REMOVAL	32	
Schematic	7	INSTALLATION	32	
Wiring Diagram—AUDIO—	8	Removal and Installation of BOSE Speaker Amplifier	32	
Wiring Diagram —REMOTE—	15	REMOVAL	32	
Wiring Diagram —CD AUTO CHANGER—	16	INSTALLATION	32	
Terminals and Reference Value for BOSE Speaker Amplifier	18	Removal and Installation of Microphone	33	
Terminals and Reference Value for Audio Unit	20	REMOVAL	33	
Terminals and Reference Value for CD Auto Changer	22	INSTALLATION	33	
Self-Diagnosis Function	23	Removal and Installation of Steering Wheel Switch	33	
DESCRIPTION	23	AUDIO ANTENNA	34	
DIAGNOSIS ITEM	23	Wiring Diagram —W/ANT—	34	
Self-Diagnosis Mode	23	Location of Antenna	35	
OPERATION PROCEDURE	23	Window Antenna Repair	35	
Trouble Diagnosis	23	ELEMENT CHECK	35	
MALFUNCTION WITH RADIO, TAPE AND CD..	24	ELEMENT REPAIR	36	
FOR RADIO ONLY	24	TELEPHONE (PRE WIRE)	37	
FOR CASSETTE PLAYER ONLY	25	Wiring Diagram — PHONE —	37	
FOR CD ONLY	25	NAVIGATION SYSTEM	38	
Noise Inspection	25	System Description	38	
TYPE OF NOISE AND POSSIBLE CAUSE	25	TRAVEL DISTANCE	38	
Power Supply Circuit Inspection	26	TRAVEL DIRECTION	38	
Audio System Does Not Turn On	27	MAP-MATCHING	38	
Steering Switch Does Not Operate	27	GPS (GLOBAL POSITIONING SYSTEM)	39	
Removal and Installation of Audio Unit	29	COMPONENT DESCRIPTION	40	
REMOVAL	29	BIRDVIEW™	40	
INSTALLATION	29	MAP DISPLAY	41	
		FUNCTION OF MULTIFUNCTION SWITCH	42	
		"VIEW" MODE	45	

A
B
C
D
E
F
G
H
I
J
AV
L
M

“GPS INFORMATION” MODE	46	RGB Screen is Rolling	91
“SAVE CURRENT LOCATION” MODE	46	Guide Sound is Not Heard	92
“QUICK STOP CUSTOMER SETTINGS” MODE ..	46	A/C is Inoperative (The Display for A/C is Not	
“AUTO RE-ROUTE” MODE	46	Shown)	93
“AVOID AREA SETTINGS” MODE	47	A/C is Inoperative (The Display for A/C is Shown)..	94
“TRACKING” MODE	47	No Fuel Information is Displayed/No Warning Mes-	
“EDIT ADDRESS BOOK” MODE	47	sage is Displayed	95
“HEADING” MODE	47	Vehicle Condition Setting is Not Possible	96
“NEARBY DISPLAY ICONS” MODE	48	Previous Conditions are Not Stored	97
“ADJUST CURRENT LOCATION” MODE	48	The Position of the Current-Location Mark is Not	
“SET AVERAGE SPEED” MODE	48	Correct	97
“CLEAR MEMORY” MODE	49	Radio Wave from the GPS Satellite is Not Received..	97
GUIDANCE VOLUME	49	Driving Test	97
Precautions for AV and NAVI Control Unit Replace-		Example of Symptoms Judged No Malfunction	99
ment	49	BASIC OPERATION	99
Component Parts Location	50	VEHICLE MARK	99
Location of Antenna	50	DESTINATION, PASSING POINTS, AND MENU	
Schematic	51	ITEMS CANNOT BE SELECTED/SET	100
Wiring Diagram —NAVI—	52	VOICE GUIDE	100
Schematic	59	ROUTE SEARCHING	101
Wiring Diagram — COMM —	60	EXAMPLES OF CURRENT-LOCATION MARK	
Terminals and Reference Value for AV and NAVI		DISPLACEMENT	102
Control Unit	64	THE CURRENT POSITION MARK SHOWS A	
On Board Self-Diagnosis Function (Without CON-		POSITION WHICH IS COMPLETELY WRONG. 105	
SULT-II)	68	THE CURRENT POSITION MARK JUMPS	105
DESCRIPTION	68	THE CURRENT LOCATION MARK IS IN A	
DIAGNOSIS ITEM	68	RIVER OR THE SEA	106
Self-Diagnosis Mode	69	WHEN DRIVING ON THE SAME ROAD, SOME-	
OPERATION PROCEDURE	69	TIMES THE CURRENT-LOCATION MARK IS IN	
SELF-DIAGNOSIS RESULT	71	THE RIGHT PLACE AND SOMETIMES IT IS THE	
Confirmation/Adjustment Mode	73	WRONG PLACE	106
OPERATION PROCEDURE	73	LOCATION CORRECTION BY MAP MATCHING	
DISPLAY DIAGNOSIS	74	IS SLOW	106
VEHICLE SIGNALS	75	ALTHOUGH THE GPS RECEIVING DISPLAY IS	
AUTO CLIMATE CONTROL	75	GREEN, THE VEHICLE MARK DOES NOT	
NAVIGATION	75	RETURN TO THE CORRECT LOCATION	106
HISTORY OF ERRORS	76	THE NAME OF THE CURRENT PLACE IS NOT	
DIAGNOSIS BY HISTORY OF ERRORS	77	DISPLAYED	106
CONSULT-II Function	79	CONTENTS OF THE DISPLAY DIFFER FOR	
OPERATION PROCEDURE	79	THE BIRDVIEW™ AND THE (FLAT) MAP	
SELF-DIAG RESULTS	80	SCREEN	106
DATA MONITOR (SIGNAL MONITOR)	81	Program Loading	107
VERSION	82	Removal and Installation of AV and NAVI Control	
Power Supply and Ground Circuit Check	83	Unit	108
Vehicle Speed Signal Check	84	REMOVAL	108
Illumination Control Signal Check	84	INSTALLATION	108
Ignition Signal Check	85	Removal and Installation of GPS Antenna	108
Reverse Signal Check	86	REMOVAL	108
RGB Screen is Not Shown	87	INSTALLATION	108
Color of RGB Image is Not Proper	88	Removal and Installation of Steering Wheel Switch 108	

PRECAUTIONS

PRECAUTIONS

PPF:00011

Precautions for Supplemental Restraint System (SRS) “AIR BAG” and “SEAT BELT PRE-TENSIONER”

AKS004FO

The Supplemental Restraint System such as “AIR BAG” and “SEAT BELT PRE-TENSIONER”, used along with a front seat belt, helps to reduce the risk or severity of injury to the driver and front passenger for certain types of collision. This system includes seat belt switch inputs and dual stage front air bag modules. The SRS system uses the seat belt switches to determine the front air bag deployment, and may only deploy one front air bag, depending on the severity of a collision and whether the front occupants are belted or unbelted. Information necessary to service the system safely is included in the SRS and SB section of this Service Manual.

WARNING:

- To avoid rendering the SRS inoperative, which could increase the risk of personal injury or death in the event of a collision which would result in air bag inflation, all maintenance must be performed by an authorized NISSAN/INFINITI dealer.
- Improper maintenance, including incorrect removal and installation of the SRS, can lead to personal injury caused by unintentional activation of the system. For removal of Spiral Cable and Air Bag Module, see the SRS section.
- Do not use electrical test equipment on any circuit related to the SRS unless instructed to in this Service Manual. SRS wiring harnesses can be identified by yellow and/or orange harnesses or harness connectors.

Wiring Diagrams and Trouble Diagnosis

AKS004FO

When you read wiring diagrams, refer to the following:

- Refer to [GI-14, "How to Read Wiring Diagrams"](#) in GI section
- Refer to [PG-2, "POWER SUPPLY ROUTING"](#) for power distribution circuit in PG section

When you perform trouble diagnosis, refer to the following:

- Refer to [GI-10, "HOW TO FOLLOW TEST GROUPS IN TROUBLE DIAGNOSES"](#) in GI section
- Refer to [GI-26, "How to Perform Efficient Diagnosis for an Electrical Incident"](#) in GI section

A
B
C
D
E
F
G
H
I
J
L
M

AV

PREPARATION

PREPARATION

PFP:00002

Commercial Service Tools

AKS003VC

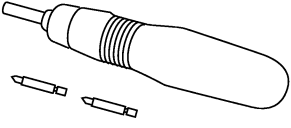
Tool name	Description
<p data-bbox="140 410 252 436">Power tool</p>  <p data-bbox="837 512 911 532">PBIC0191E</p>	<p data-bbox="997 310 1252 336">Loosening bolts and nuts</p>

AUDIO

PFP:28111

System Description AUDIO SYSTEM

AKS002NH

Refer to Owner's Manual for audio system operating instructions.

Power is supplied at all times

- through 15A fuse [No. 52, located in the fuse, fusible link and relay block (J/B)]
- to audio unit terminal 73
- to CD auto changer terminal 12
- through 20A fuse (No. 75, located in the fuse, fusible link and relay box)
- to BOSE speaker amp. terminal 11.

With the ignition switch in the ACC or ON position, power is supplied

- through 10A fuse [No. 21, located in the fuse block (J/B) No.1]
- to audio unit terminal 72 and BOSE speaker amp. terminal 34.
- to CD auto changer terminal 16.

Ground is supplied through the case of the audio unit.

Ground is also supplied to CD auto changer terminal 15 through body grounds M24 and M114.

Ground is also supplied to BOSE speaker amp. terminal 27 through body grounds B217 and B256.

Audio unit is connected to BOSE speaker amp. as communication line.

When the audio unit is turned to the ON position, audio sound signals are supplied.

- through audio unit terminals 12,11
- to BOSE speaker amp. terminals 5, 6.

When the audio unit is turned to the ON position, audio signals are supplied.

- through terminals 79, 80, 81 and 82 of audio unit
- to terminals 39, 40, 38 and 41 of the BOSE speaker amp.
- through terminals 18, 19, 21, 20, 23, 22, 28, 12, 16, 17, 25, 24, 30 and 14 of the BOSE speaker amp.
- to instrument panel speakers, front and rear door speakers and woofer terminals 1 and 2.

When steering switch pushed ON, signal is sent

- from steering switch terminal 2
- through combination switch (spiral cable) terminals 15 and 7
- to multi-function switch terminal 7, then
- to audio unit.

AV COMMUNICATION LINE

Audio system components (Audio unit, BOSE speaker amplifier, etc.) are connected by AV communication line and controlled by signals from the multi-function switch.

AUDIPILOT™ SYSTEM

AudioPilot™ is the sound improving system that picks up any noises or the sound of music coming into the vehicle by a microphone equipped with audio unit, and that the BOSE speaker amp. revises the frequency feature of music at real time in response to the frequency feature of the noise while driving and listening to music.

- If low frequency area noise from vehicle is loud, it adjusts low frequency element of music to be bigger than vehicle noise.
- If high frequency area noise from vehicle is loud, it adjusts high frequency element of music to be bigger than vehicle noise.
- If vehicle noise is smaller than the setting volume, correction is not performed.

This compensate vehicle noise when listening to music.

AUDIO

Component Parts Location

AKS004XR

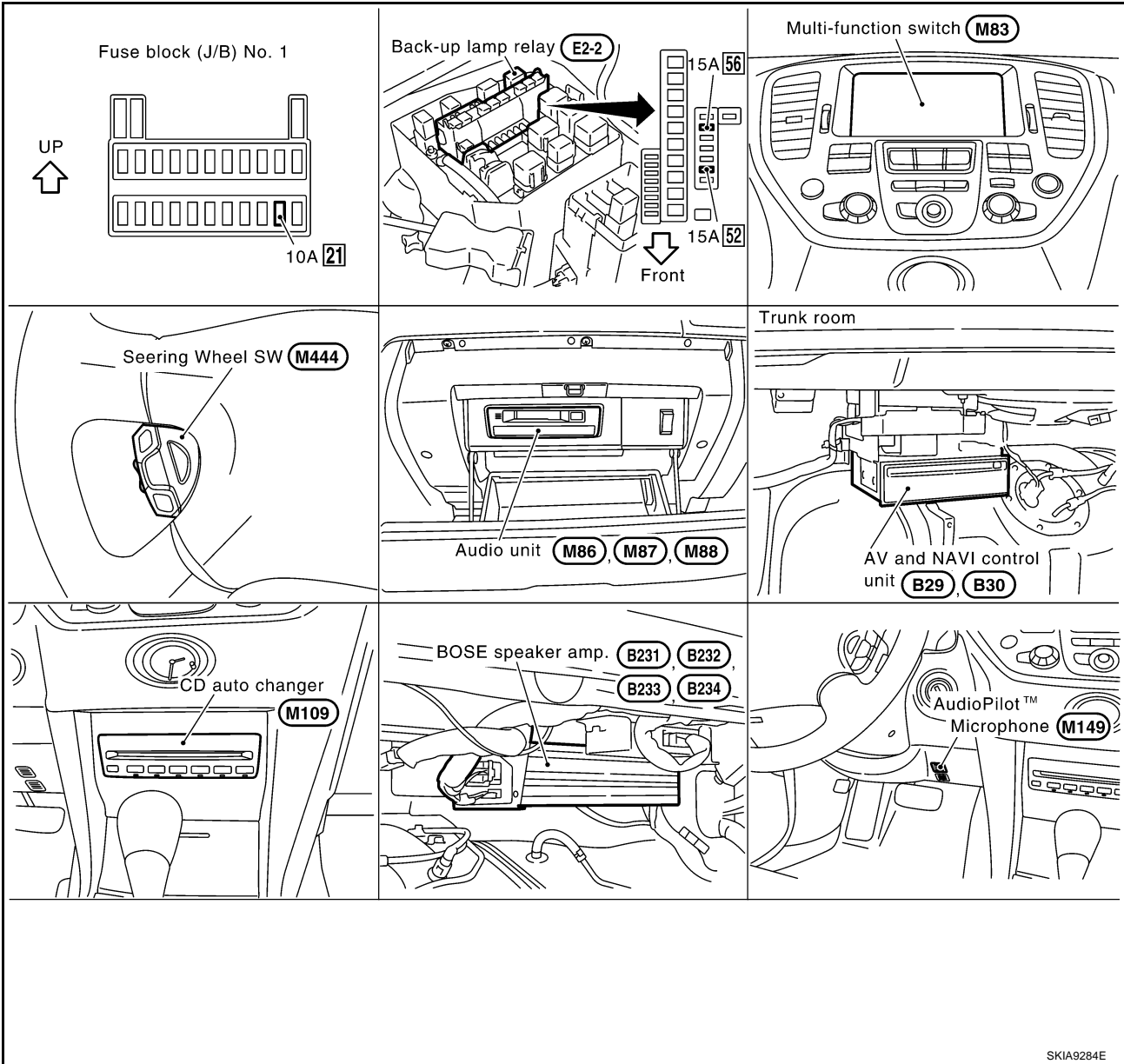

SKIA9284E

AUDIO

Schematic

AKS002NI

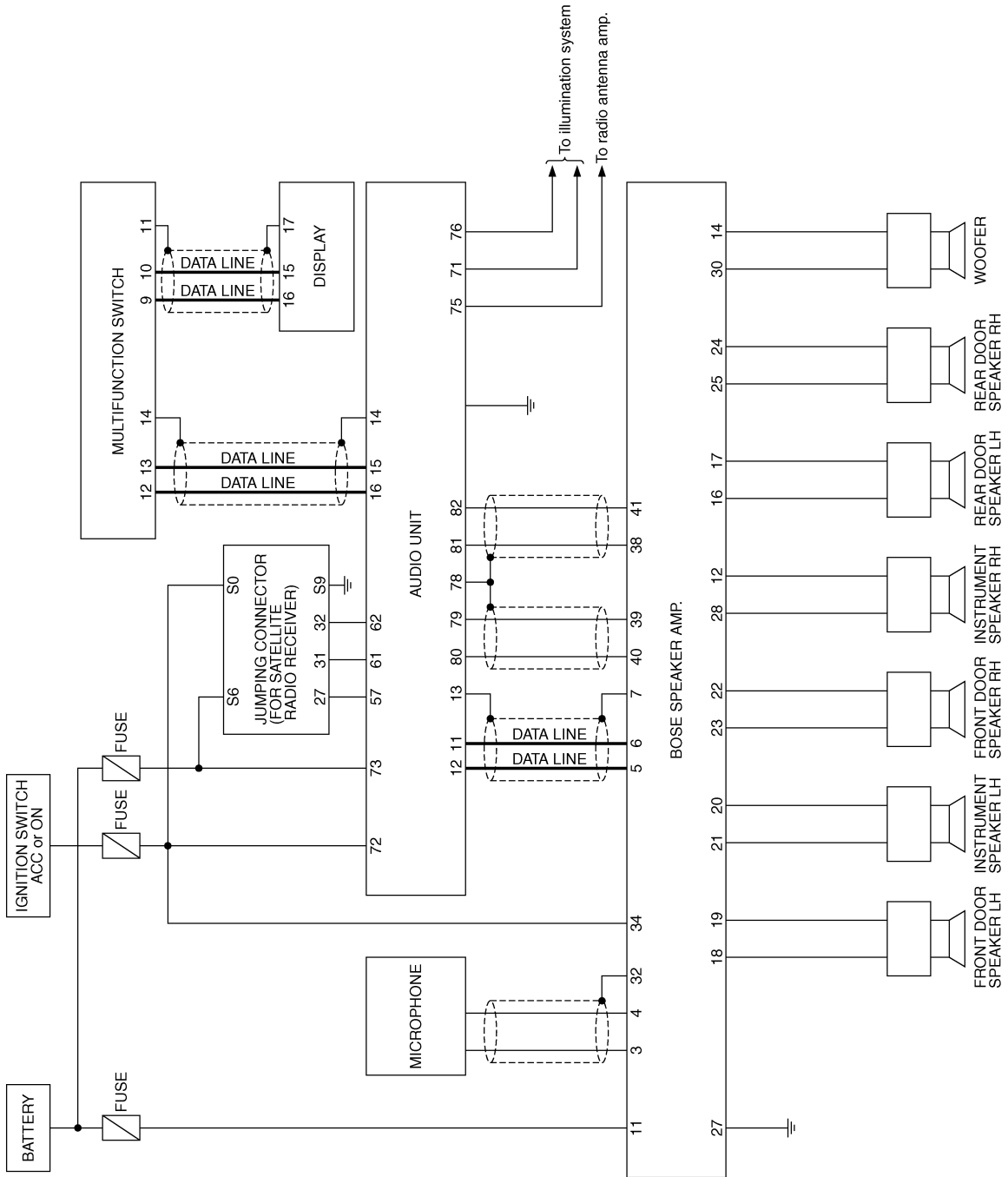

A
B
C
D
E
F
G
H
I
J
L
M

AV

TKWA1652E

AUDIO

AKS002NJ

Wiring Diagram—AUDIO—

AV-AUDIO-01

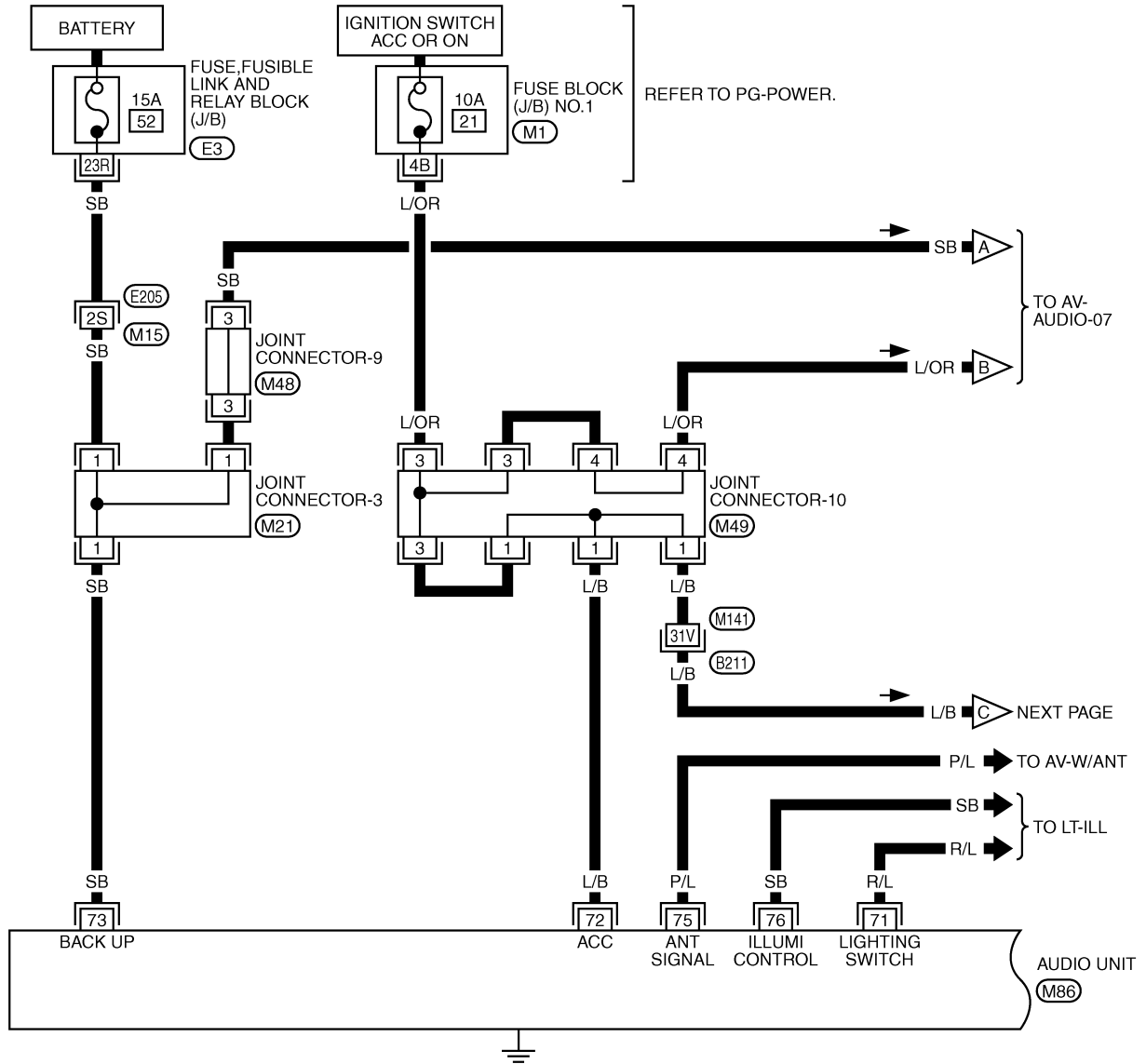

(M21)
GY

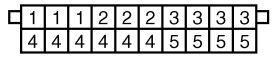

(M48)
B

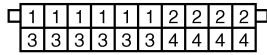

(M49)
L

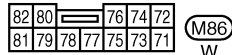

(M86)
W

REFER TO THE FOLLOWING.

(E205), (B211) -SUPER MULTIPLE JUNCTION (SMJ)

(M1) -FUSE BLOCK-JUNCTION BOX (J/B) NO.1

(E3) -FUSE, FUSIBLE LINK AND RELAY BLOCK (J/B)

TKWA1240E

AUDIO

AV-AUDIO-02

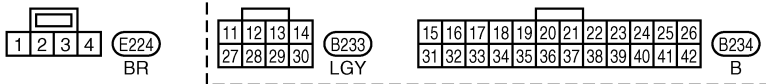
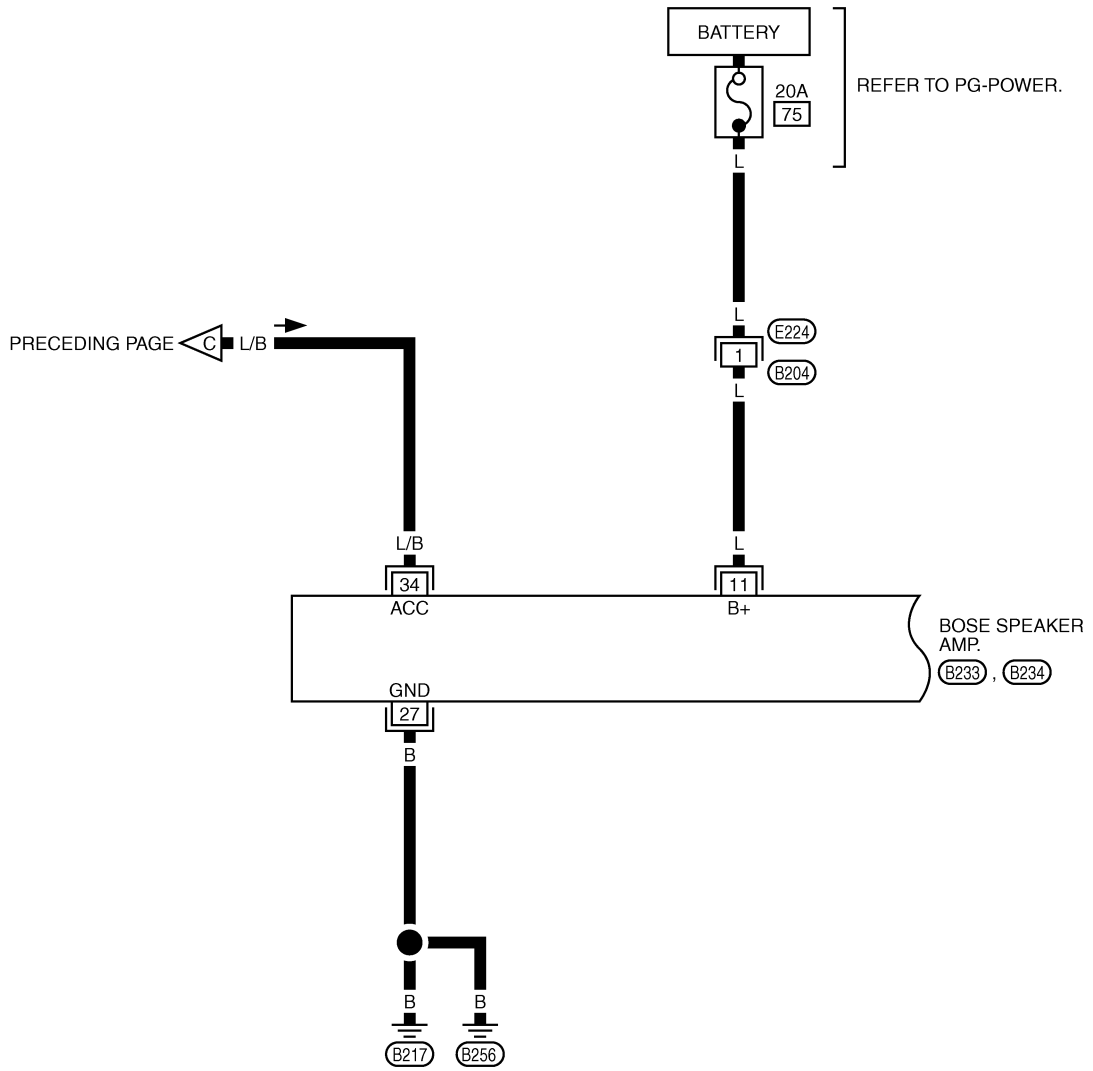

TKWA1241E

AUDIO

AV-AUDIO-03

▬ : DATA LINE

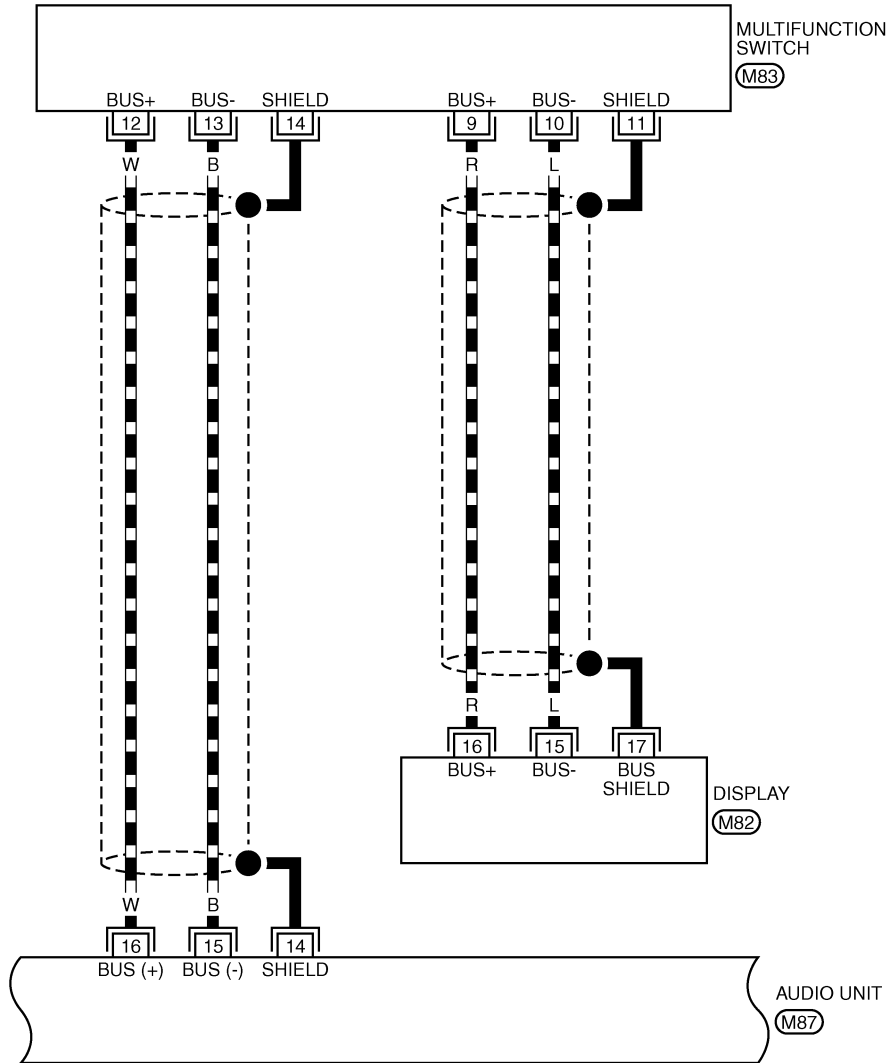

24	22	20	18	16	14	12	10	8	6	4	2
23	21	19	17	15	13	11	9	7	5	3	1

(M82)
GY

20	18	16	14	12	10	8	6	4	2	
19	17	15	13	11	10	9	7	5	3	1

(M83)
W

16	14	12	10	8	6	4	2	
15	13	11	10	9	7	5	3	1

(M87)
W

TKWA0651E

AUDIO

AV-AUDIO-04

▬ : DATA LINE

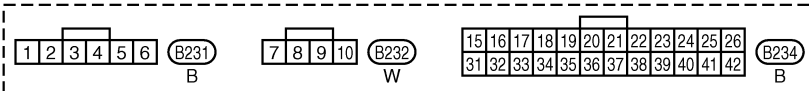
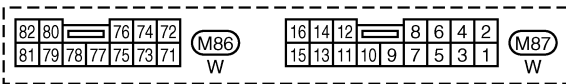
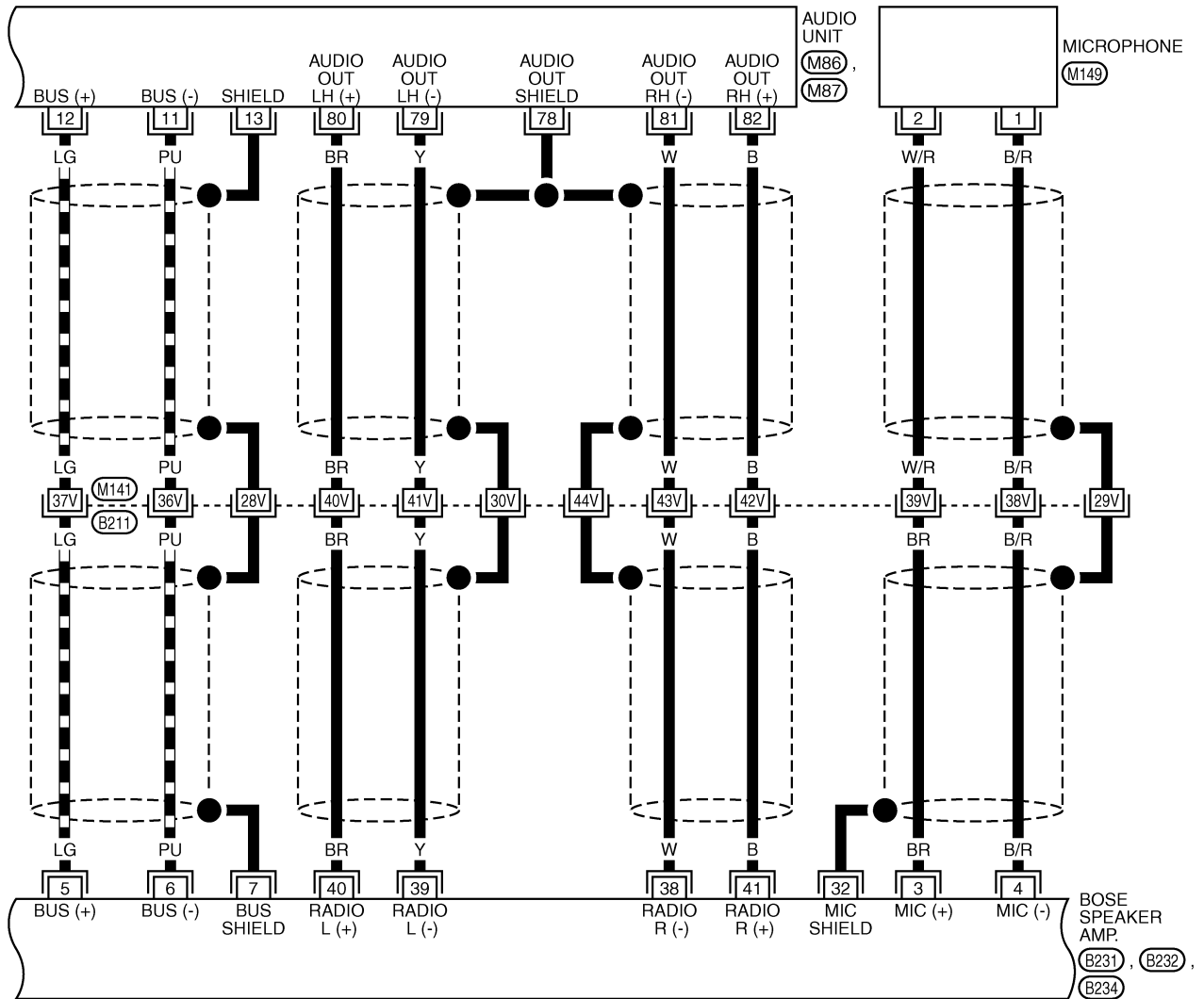

REFER TO THE FOLLOWING.

B211 -SUPER MULTIPLE JUNCTION (SMJ)

TKWA1653E

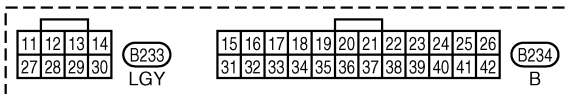
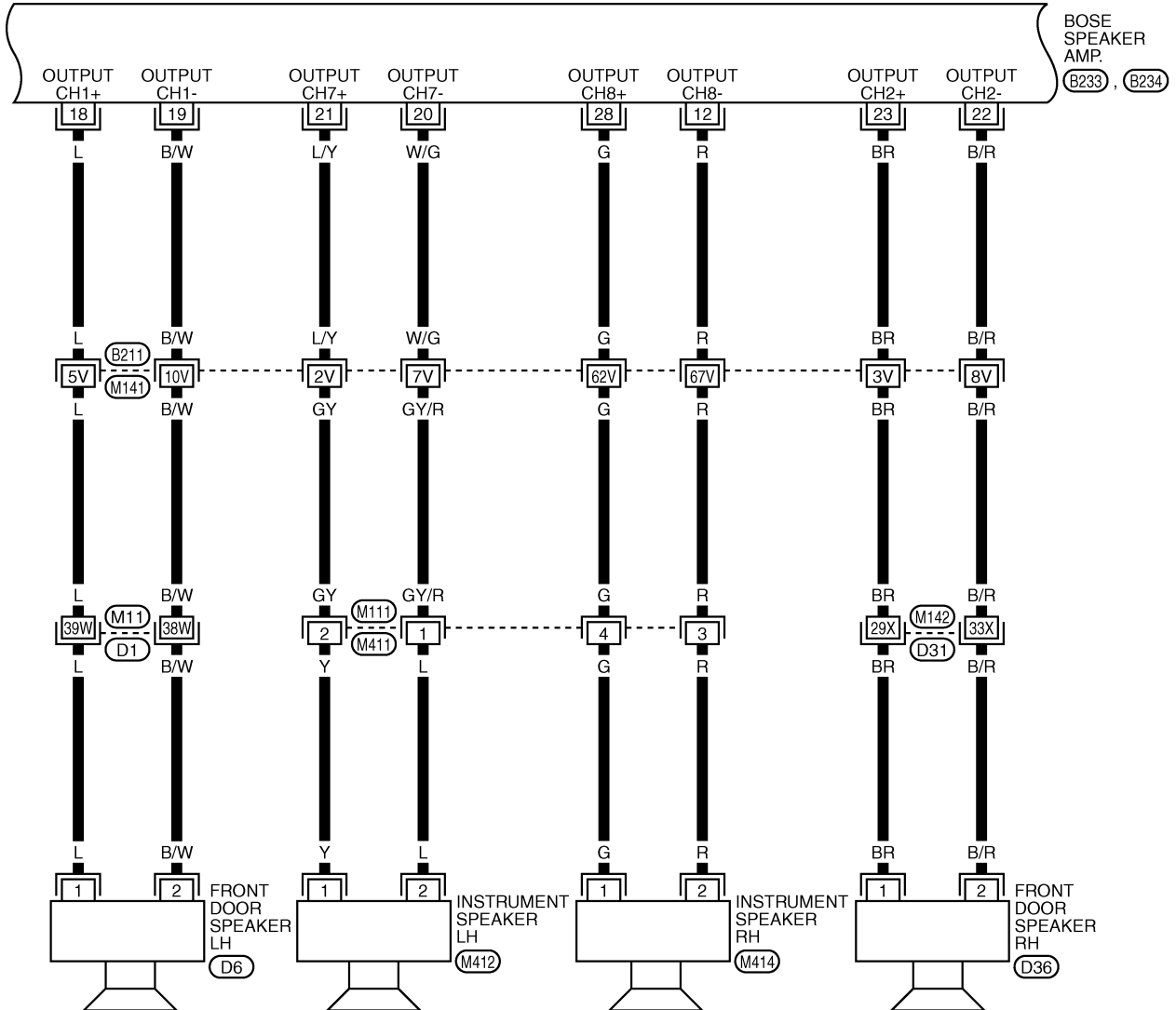

REFER TO THE FOLLOWING.
(B211) (D1) (D31) -SUPER
MULTIPLE JUNCTION (SMJ)

AUDIO

AV-AUDIO-06

A
B
C
D
E
F
G
H
I
J
AV
L
M

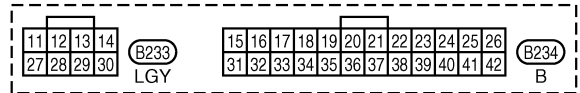
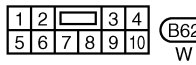
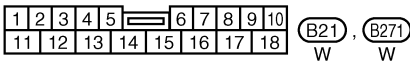
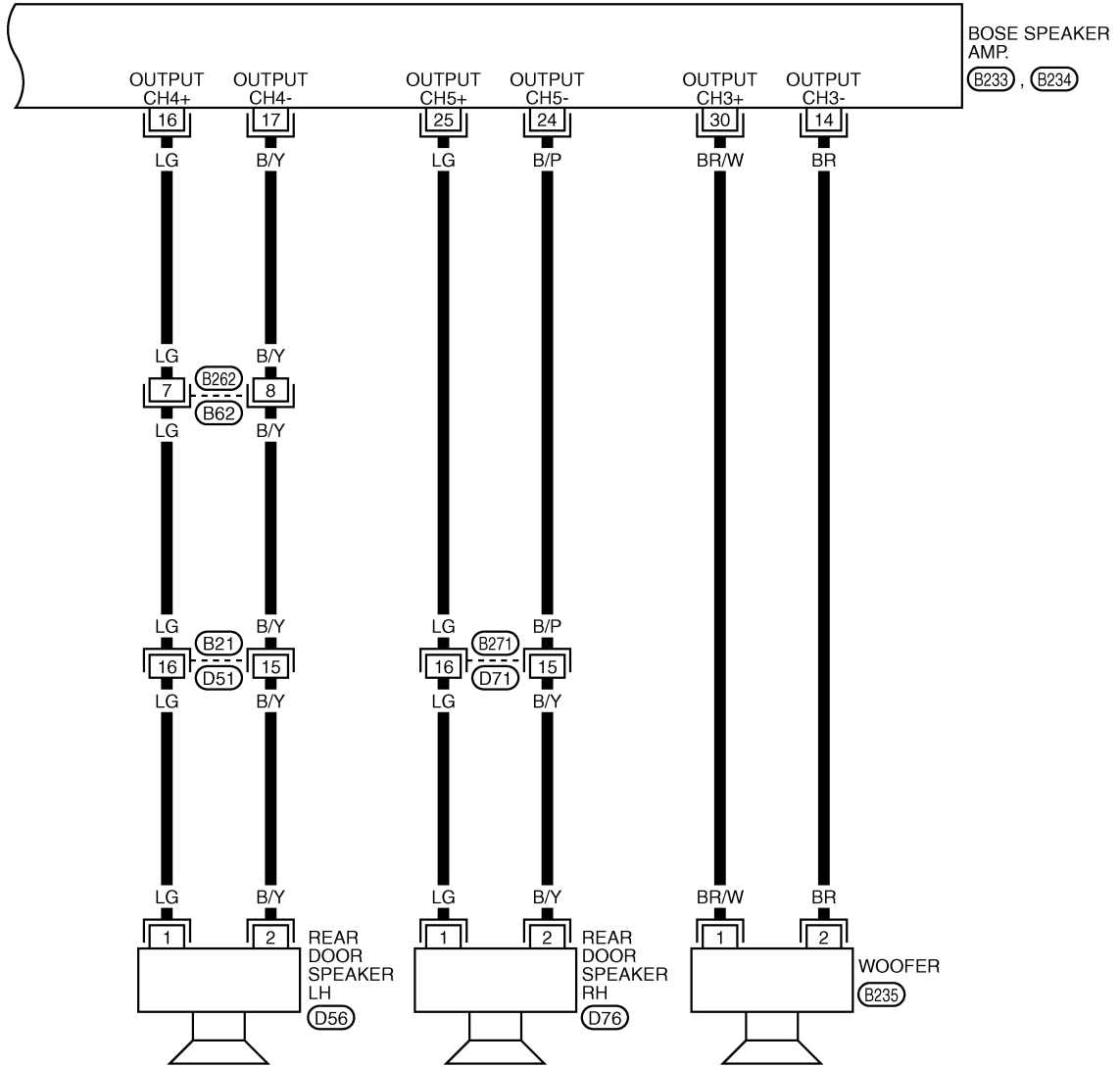

TKWA0654E

AUDIO

AV-AUDIO-07

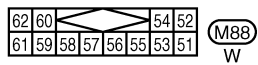
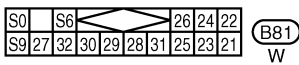
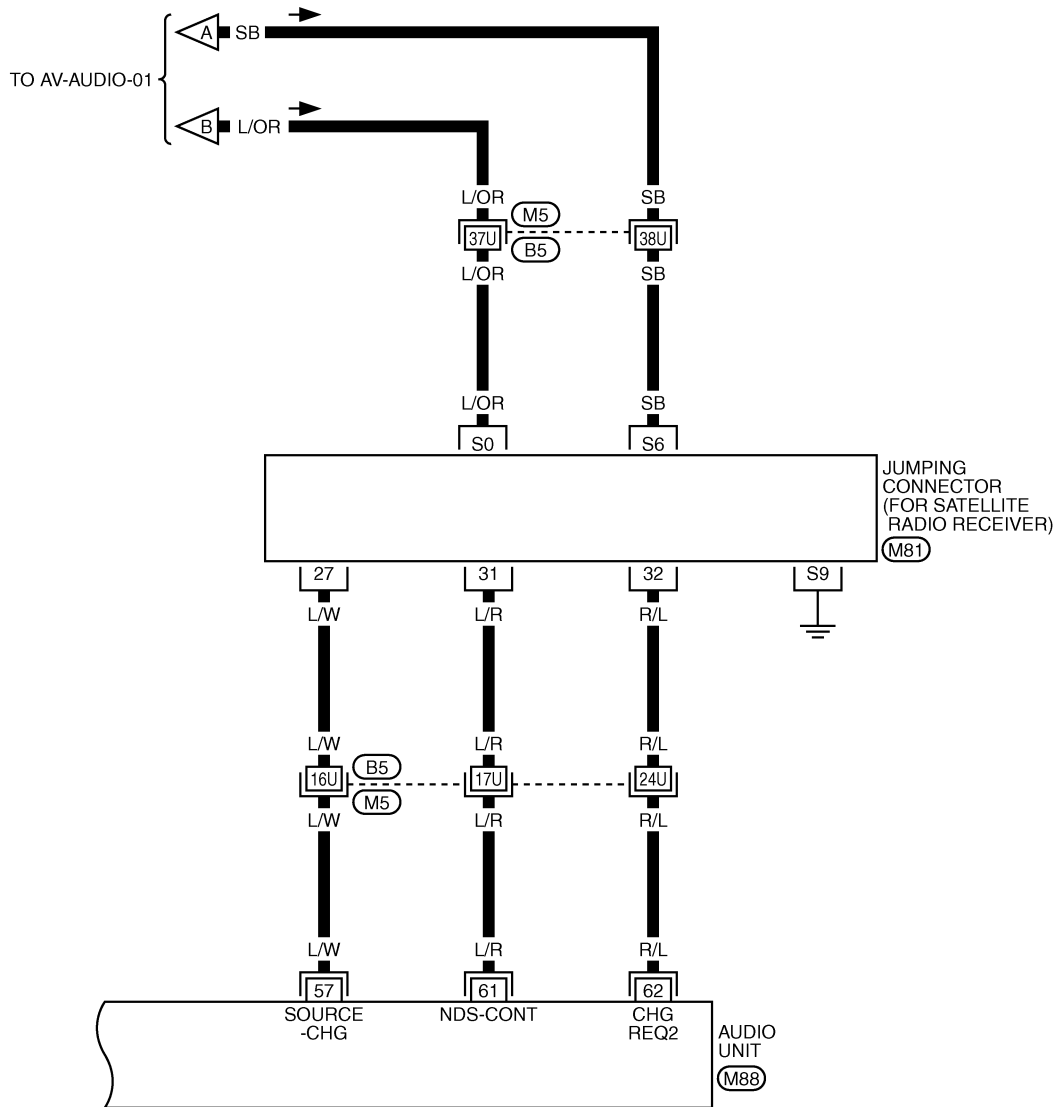

REFER TO THE FOLLOWING.
(M5) -SUPER MULTIPLE JUNCTION (SMJ)

TKWA1242E

AUDIO

Wiring Diagram —REMOTE—

AKS002NK

AV-REMOTE-01

▬ : DATA LINE

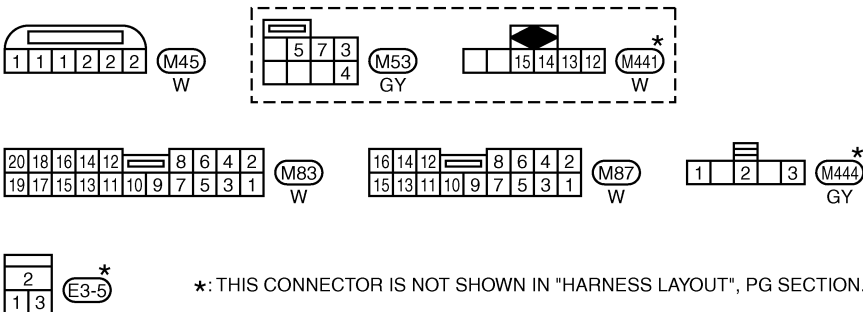
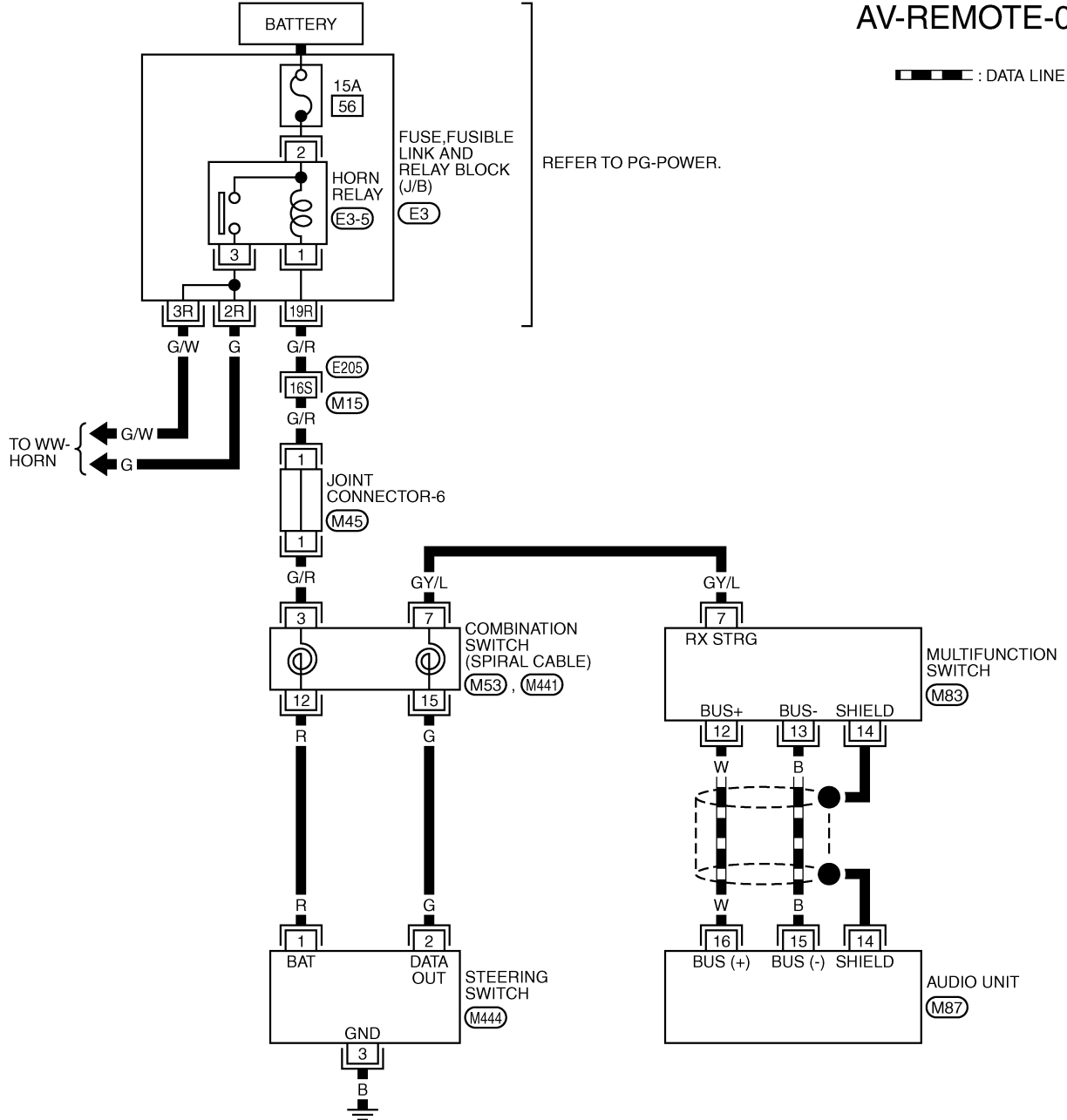

REFER TO THE FOLLOWING.

- (E205) -SUPER MULTIPLE JUNCTION (SMJ)
- (E3) -FUSE, FUSIBLE LINK AND RELAY BLOCK (J/B)

TKWA0658E

AUDIO

AKS002NL

Wiring Diagram —CD AUTO CHANGER—

AV-CD/CHG-01

▬ : DATA LINE

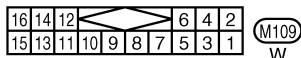
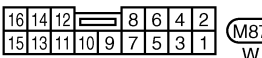
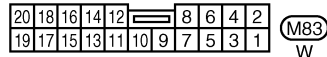
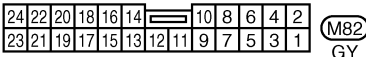
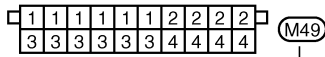
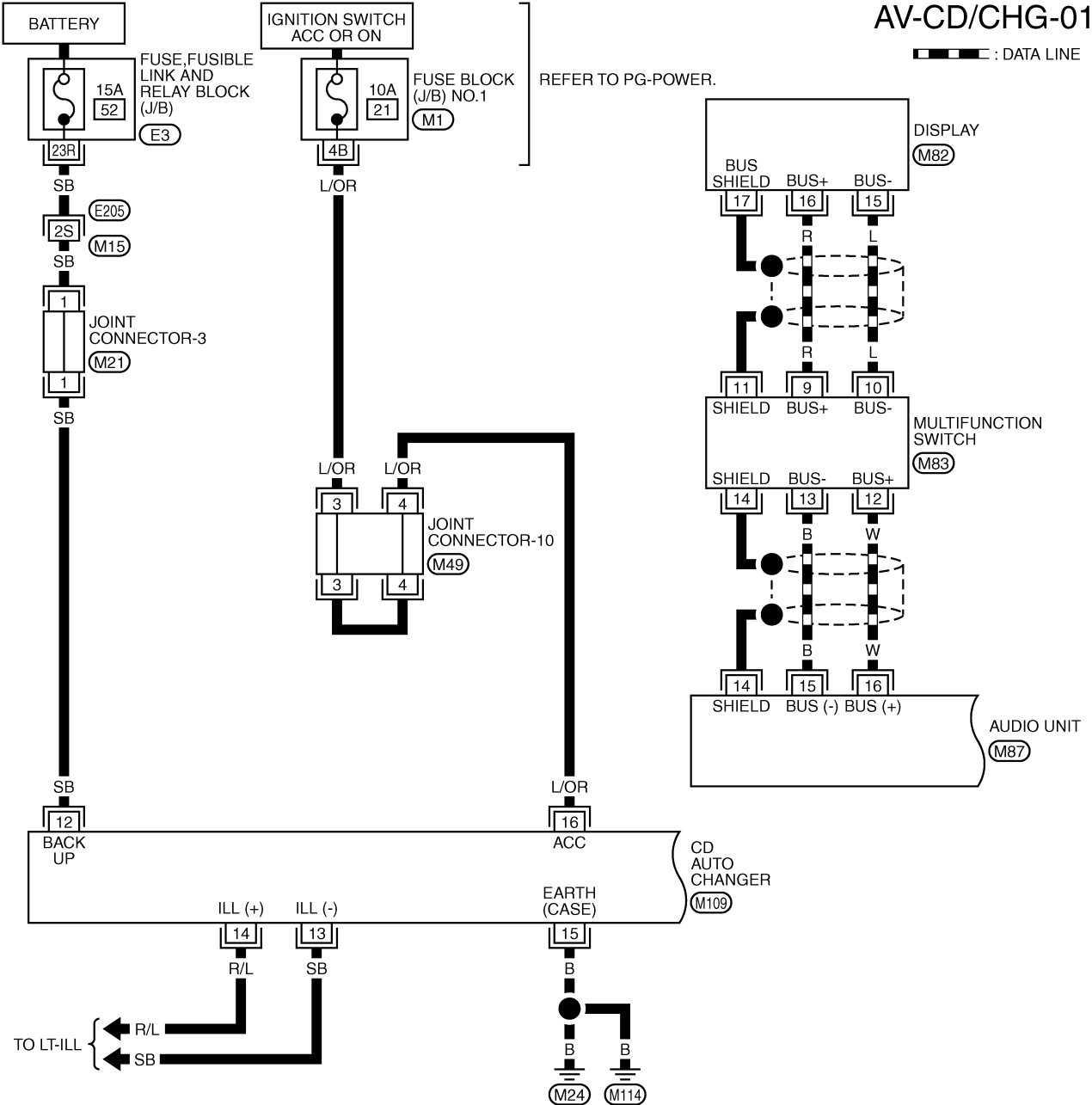

REFER TO THE FOLLOWING.

- (E205) -SUPER MULTIPLE JUNCTION (SMJ)
- (M1) -FUSE BLOCK-JUNCTION BOX (J/B) NO.1
- (E3) -FUSE,FUSIBLE LINK AND RELAY BLOCK (J/B)

TKWB0119E

AUDIO

AV-CD/CHG-02

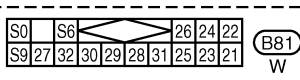
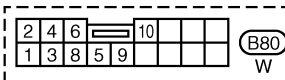
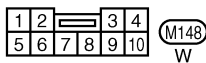
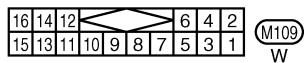
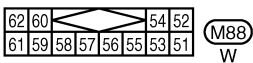
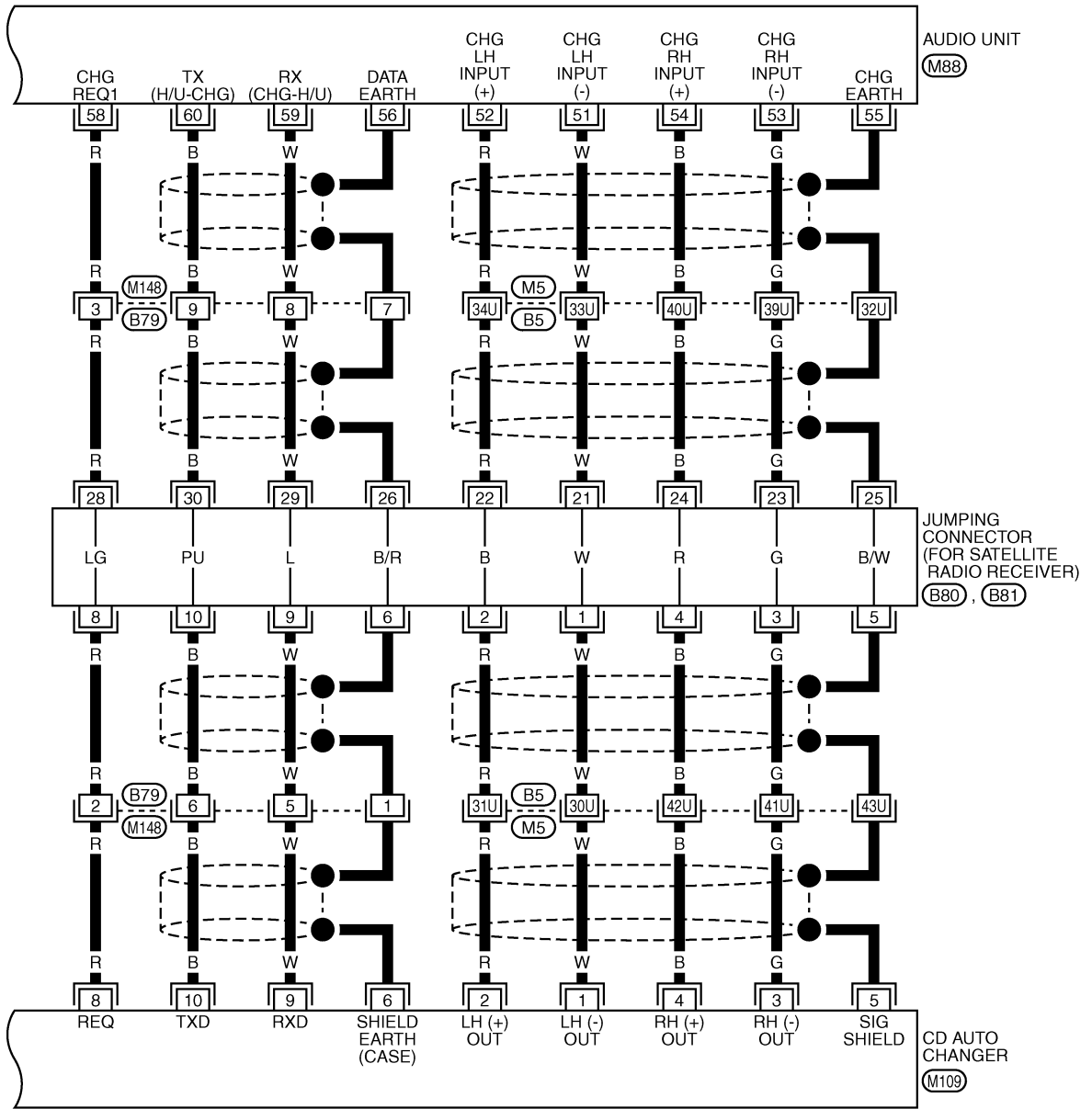

REFER TO THE FOLLOWING.

(M5) -SUPER MULTIPLE JUNCTION (SMJ)

A
B
C
D
E
F
G
H
I
J
AV
L
M

AUDIO

Terminals and Reference Value for BOSE Speaker Amplifier

AKS002NM

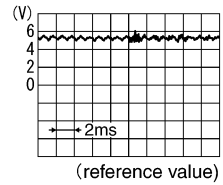
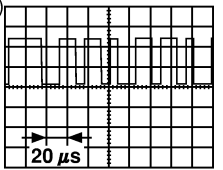
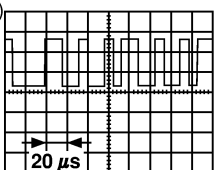
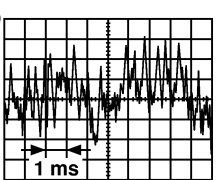
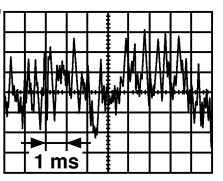
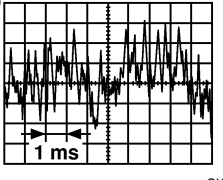
Terminal No. (wire color)		Item	Signal input/ output	Condition		Voltage	Example of symp- tom
+	-			Ignition switch	Operation		
3 (BR)	4 (B/R)	Microphone	Input	ON	-	 <p>(reference value) PKIA2104E</p>	Noise compensa- tion function does not operate.
5 (LG)	Ground	Communica- tion signal (+)	Input/ output	ON	-	 <p>SKIA0175E</p>	System does not work properly.
6 (PU)	Ground	Communica- tion signal (-)	Input/ output	ON	-	 <p>SKIA0176E</p>	System does not work properly.
7	-	Shield ground	-	-	-	-	-
11 (L)	Ground	Battery power	Input	OFF	-	Battery voltage	System does not operate.
16 (LG)	17 (B/Y)	Rear door speaker LH output	Output	ON	Receive radio broadcast	 <p>SKIA0177E</p>	No sound from rear door speaker LH.
18 (L)	19 (B/W)	Front door speaker LH output	Output	ON	Receive radio broadcast	 <p>SKIA0177E</p>	No sound from front door speaker LH.
21 (L/Y)	20(W/G)	Instrument speaker LH output	Output	ON	Receive radio broadcast	 <p>SKIA0177E</p>	No sound from Instrument speaker LH.

AUDIO

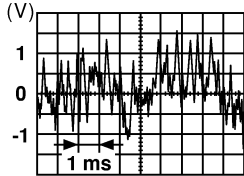
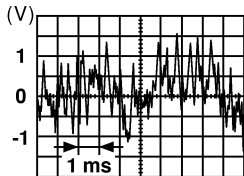
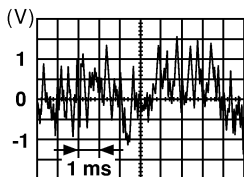
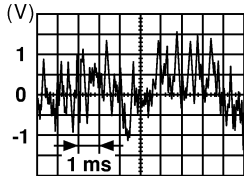
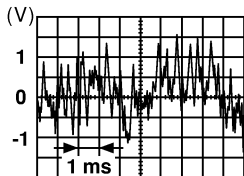
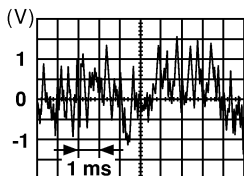
Terminal No. (wire color)		Item	Signal input/ output	Condition		Voltage	Example of symp- tom
+	-			Ignition switch	Operation		
23 (BR)	22 (B/R)	Front door speaker RH output	Output	ON	Receive radio broadcast	 SKIA0177E	No sound from front door speaker RH.
25 (LG)	24 (B/P)	Rear door speaker RH output	Output	ON	Receive radio broadcast	 SKIA0177E	No sound from rear door speaker RH.
27(B)	Ground	Ground	-	ON	-	Approx. 0V	-
28 (G)	12 (R)	Instrument speaker RH output	Output	ON	Receive radio broadcast	 SKIA0177E	No sound from Instrument speaker RH.
30 (BR/W)	14 (BR)	Woofers output	Output	ON	-	 SKIA0177E	No sound from Woofers.
32	-	Shield	-	-	-	-	-
34 (L/B)	Ground	ACC power	Input	ACC	-	Battery voltage	AV functions do not operate.
40 (BR)	39 (Y)	Audio sound signal (LH)	Input	ON	Play cassette tape.	 SKIA0177E	Audio sound not heard from LH speaker.
41 (B)	38 (W)	Audio sound signal (RH)	Input	ON	Play cassette tape.	 SKIA0177E	Audio sound not heard from RH speaker.

A
B
C
D
E
F
G
H
I
J

AV

L
M

AUDIO

Terminals and Reference Value for Audio Unit

AKS002NN

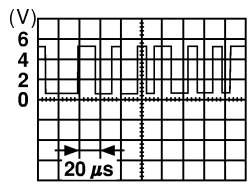
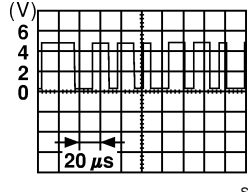
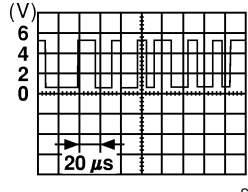
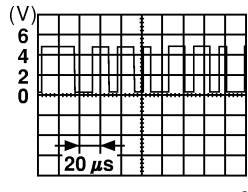
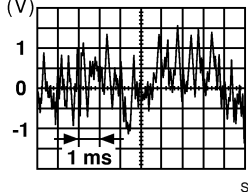
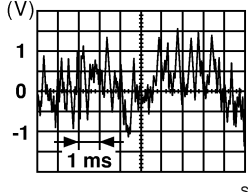
Terminal No.		Item	Signal input/output	Condition		Voltage	Example of symptom
+	-			Ignition switch	Operation		
11 (PU)	Ground	Communication signal (-)	Input/output	ON	-	 <p style="text-align: right; font-size: small;">SKIA0176E</p>	System does not work properly.
12 (LG)	Ground	Communication signal (+)	Input/output	ON	-	 <p style="text-align: right; font-size: small;">SKIA0175E</p>	System does not work properly.
13	-	Shield ground	-	-	-	-	-
14	-	Shield ground	-	-	-	-	-
15 (B)	Ground	Communication signal (-)	Input/output	ON	-	 <p style="text-align: right; font-size: small;">SKIA0176E</p>	System does not work properly.
16 (W)	Ground	Communication signal (+)	Input/output	ON	-	 <p style="text-align: right; font-size: small;">SKIA0175E</p>	System does not work properly.
52 (R)	51 (W)	CD sound signal (LH)	Input	ON	Play CD.	 <p style="text-align: right; font-size: small;">SKIA0177E</p>	CD sound is not heard from speaker LH.
54 (B)	53 (G)	CD sound signal (RH)	Input	ON	Play CD.	 <p style="text-align: right; font-size: small;">SKIA0177E</p>	CD sound is not heard from speaker RH.
55	-	Shield ground (signal)	-	-	-	-	-
56	-	Shield ground (signal)	-	-	-	-	-

AUDIO

Terminal No.		Item	Signal input/output	Condition		Voltage	Example of symptom
+	-			Ignition switch	Operation		
58 (R)	Ground	Communication signal (CHG REQ)	Input	ON	Insert/eject magazine.	 SKIA0196E	CD auto changer operation is not possible.
59 (W)	Ground	Communication signal (CHG-H/U)	Input	ON	Insert/eject magazine.	 SKIA0197E	CD auto changer operation is not possible.
60 (B)	Ground	Communication signal (H/U-CHG)	Output	ON	Press the CD switch.	 SKIA0198E	CD auto changer operation is not possible.
71 (R/L)	Ground	Illumination signal	Input	OFF	Lighting switch is ON (1st position).	Battery voltage	Audio unit illumination does not come on when lighting switch is ON (1st position).
					Turn lighting switch OFF.	Approx. 0V	
72 (L/B)	Ground	ACC power	Input	ACC	-	Battery voltage	Audio unit operation is not possible.
73 (SB)	Ground	Battery power	Input	OFF	-	Battery voltage	Cassette tape player operation is not possible.
75 (P/L)	Ground	Radio antenna amp. ON signal	Output	ON	-	Approx. 10V or more	Receiving status of radio broadcast becomes bad.
76 (SB)	Ground	Illumination control signal	Input	ON	Illumination control switch is operated by lighting switch in 1st position.	Changes between approx. 0 and approx. 12V.	Audio unit illumination cannot be controlled.
78	-	Shield (Audio sound signal)	-	-	-	-	-

A
B
C
D
E
F
G
H
I
J
L
M

AV

AUDIO

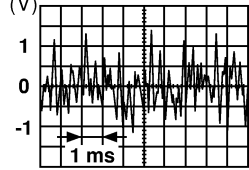
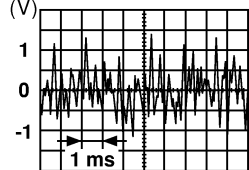
Terminal No.		Item	Signal input/output	Condition		Voltage	Example of symptom
+	-			Ignition switch	Operation		
80 (BR)	79 (Y)	Audio sound signal (LH)	Output	ON	Play cassette tape.	 <small>SKIA0195E</small>	Audio sound is not heard from speaker LH.
82 (B)	81 (W)	Audio sound signal (RH)	Output	ON	Play cassette tape.	 <small>SKIA0195E</small>	Audio sound is not heard from speaker RH.

Terminals and Reference Value for CD Auto Changer

AKS002NO

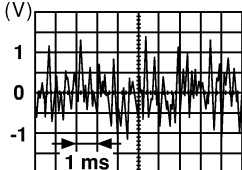
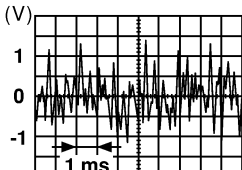
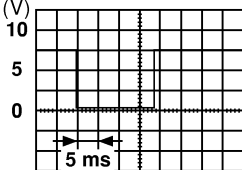
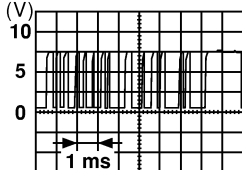
Terminal No.		Signal name	Signal input/output	Condition		Voltage	Example of symptom
+	-			Ignition switch	Operation		
2 (L)	1 (P)	CD sound signal (LH)	Output	ON	Play CD.	 <small>SKIA0195E</small>	CD sound is not heard from speaker LH.
4 (LG)	3 (PU)	CD sound signal (RH)	Output	ON	Play CD.	 <small>SKIA0195E</small>	CD sound is not heard from speaker RH.
6	-	Shield (CD sound signal)	-	-	-	-	-
8 (R)	Ground	Communication signal (REQ)	Output	ON	Insert/eject magazine.	 <small>SKIA0196E</small>	CD auto changer operation is not possible.
9 (W)	Ground	Communication signal (TXD)	Output	ON	Insert/eject magazine.	 <small>SKIA0197E</small>	CD auto changer operation is not possible.

AUDIO

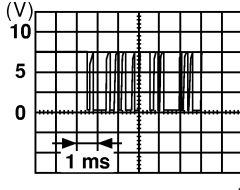
Terminal No.		Signal name	Signal input/output	Condition		Voltage	Example of symptom
+	-			Ignition switch	Operation		
10 (B)	Ground	Communication signal (RXD)	Input	ON	Press the CD switch.		CD auto changer operation is not possible.
12 (SB)	Ground	Battery power	Input	OFF	-	Battery voltage	CD auto changer operation is not possible.
13 (SB)	Ground	Illumination signal (-)	Input	OFF	Illumination control switch is operated by lighting switch in 1st position.	Changes between approx. 0V and approx. 12V.	CD auto changer illumination does not come on when lighting switch is ON (1st position).
14 (R/L)	Ground	Illumination signal (+)	Input	OFF	Lighting switch ON (1st position).	Approx. 12V	CD auto changer illumination cannot be controlled.
					Lighting switch OFF.	Approx. 0V	
15 (B)	Ground	Ground	-	ON	-	Approx. 0V	-
16 (L/OR)	Ground	ACC power	Input	ACC	-	Battery voltage	CD auto changer operation is not possible.

Self-Diagnosis Function DESCRIPTION

AKS002NQ

- Diagnosis function consists of the self-diagnosis mode, and the "CONFIRMATION/ADJUSTMENT" mode.
- Self-diagnosis mode checks for connection among audio unit, and CD auto changer and analyzes each unit, then displays the results.

DIAGNOSIS ITEM

Mode	Description
Self-diagnosis	<ul style="list-style-type: none"> ● Check connection among AV and NAVI control unit or AV control unit and audio unit and CD auto changer. ● Perform the unit diagnosis of audio unit and CD auto changer.

Self-Diagnosis Mode OPERATION PROCEDURE

AKS002NR

- To start the self-diagnosis mode and to check the diagnosis result, refer to [AV-69, "Self-Diagnosis Mode"](#) for models with navigation system, and [DI-113, "Self-Diagnosis Mode"](#) for vehicles without navigation system.

Trouble Diagnosis

AKS002NT

- The majority of the audio troubles are the result of outside causes (bad CD/cassette, electromagnetic interference, etc.). Check the inspection items below to diagnose the malfunction.

AUDIO

MALFUNCTION WITH RADIO, TAPE AND CD

Symptom	Check items	Possible cause
Inoperative	<ul style="list-style-type: none"> ● Make sure the ignition switch is in the ACC position. 	<ul style="list-style-type: none"> ● Audio unit ● Audio unit power supply circuit. Refer to AV-26, "Power Supply Circuit Inspection"
No sound	<ul style="list-style-type: none"> ● Make sure the volume is not turned down. ● Make sure the balance and fader control knobs are centered. 	<ul style="list-style-type: none"> ● Audio unit ● Audio unit power supply circuit. Refer to AV-26, "Power Supply Circuit Inspection" ● Speaker ● Sound signal circuit between speaker and audio unit
Poor sound	<ul style="list-style-type: none"> ● Make sure the bass and treble adjustment knobs are centered. 	<ul style="list-style-type: none"> ● audio unit ● CD auto changer ● Speaker ● BOSE speaker amp.
Noisy	-	<ul style="list-style-type: none"> ● Audio unit ● CD auto changer ● Each electrical equipment ● BOSE speaker amp.

FOR RADIO ONLY

Symptom	Check items	Possible cause
No sound	<ul style="list-style-type: none"> ● Make sure the radio is tuned to a station's frequency. 	<ul style="list-style-type: none"> ● Audio unit ● Antenna feeder ● Antenna amplifier ● Glass antenna
Noisy	<ul style="list-style-type: none"> ● Make sure the radio is tuned to a station's frequency. ● Make sure the signal of the received station is not weak. ● Make sure no mirror-type window film nor any metal object (after-market antenna, etc.) is attached on the rear window glass (Note 1). ● Check whether or not the malfunction occurs only in a particular area. (Note 2) 	<ul style="list-style-type: none"> ● Audio unit ● Antenna feeder ● Antenna amplifier ● window antenna ● Noise prevention parts ● Each electrical equipment ● Wire harness of each piece of electrical equipment
Selected radio stations stored in memory are deleted	-	<ul style="list-style-type: none"> ● Audio unit ● Audio unit power supply circuit. Refer to AV-26, "Power Supply Circuit Inspection"

NOTE:

1. The cause is a reduction in the receiving sensitivity of the window antenna.
2. This is noise resulting from variations in field strength, such as fading noise and multi-path noise, or external noise from trains and other sources. It is not a malfunction.
 - Fading noise: This noise occurs because of variations in the field strength in a narrow range due to mountains or buildings blocking the signal.
 - Multi-path noise: This noise results from the waves sent directly from the broadcast station arriving at the antenna at a different time from the waves which reflect off of mountains or buildings.

AUDIO

FOR CASSETTE PLAYER ONLY

Symptom	Check items	Possible cause
Cassette tape cannot be inserted.	<ul style="list-style-type: none"> ● Make sure a cassette tape is not already inserted. ● Make sure the cassette has no deformation or other malfunction. 	Audio unit Audio unit power supply circuit. Refer to AV-26, "Power Supply Circuit Inspection"
Cassette tape cannot be ejected.	<ul style="list-style-type: none"> ● Make sure the cassette has no deformation or other malfunction. ● Make sure the cassette tape does not sag. 	
Auto reverse does not work, or the tape direction changes in the middle of play.	<ul style="list-style-type: none"> ● There is a malfunction with tape winding. Make sure there is no slack or other malfunction. ● Make sure an old cassette tape is not being used. 	Audio unit
There is much noise.	<ul style="list-style-type: none"> ● Make sure the cassette tape itself does not have a lot of noise, or that the tape does not have a low recording level. 	
The sound is not clear.	<ul style="list-style-type: none"> ● Make sure the tune is recorded on tape with Dolby B NR OFF and played with Dolby B NR ON. ● Make sure the sound quality of the cassette tape itself is not poor. 	
Sound fluctuates/tape speed not correct	<ul style="list-style-type: none"> ● Make sure there is no tape winding malfunction, sagging, stretching, or other malfunction. ● Make sure there is no malfunction with the recording speed of the cassette tape. 	
No sound.	<ul style="list-style-type: none"> ● Make sure the cassette tape has been recorded on. 	

FOR CD ONLY

Symptom	Check items	Possible cause
The CD cannot be played.	<ul style="list-style-type: none"> ● Make sure the CD is not upside down. ● Make sure there is no dirt, damage, or water on the disc. 	CD auto changer
The sound skips, stops suddenly, or is distorted.	<ul style="list-style-type: none"> ● Make sure there is no dirt, damage, or water on the disc. ● Make sure the trouble is not due to strong vibration. 	

Noise Inspection

AKS002NU

The vehicle itself can be a source of noise if noise prevention parts or electrical equipment is malfunction. Check if noise is caused and/or changed by engine rotation, ignition switch turned to each position, and operation of each piece of electrical equipment, and determine the cause.

NOTE:

The source of the noise can be found easily by listening to the noise while removing the fuses of electrical components, one by one.

TYPE OF NOISE AND POSSIBLE CAUSE

Occurrence condition	Possible cause	
Occurs only when engine is ON.	A continuous growling noise occurs. The speed of the noise varies with changes in the engine speed.	<ul style="list-style-type: none"> ● Malfunction with the ignition condenser.
	A whistling noise occurs while the engine speed is high. A booming noise occurs while the engine is running and the lighting switch is ON.	<ul style="list-style-type: none"> ● Malfunction with the alternator
The occurrence of the noise is linked with the operation of the fuel pump.	<ul style="list-style-type: none"> ● Malfunction with the fuel pump condenser 	
Noise only occurs when various electrical components are operating.	A cracking or snapping sound occurs with the operation of various switches.	<ul style="list-style-type: none"> ● Relay malfunction, radio malfunction
	The noise occurs when various motors are operating.	<ul style="list-style-type: none"> ● Malfunction with the motor case ground ● Malfunction with the motor

AUDIO

Occurrence condition	Possible cause
The noise occurs constantly, not just under certain conditions.	<ul style="list-style-type: none"> ● Rear window defogger coil malfunction ● Open circuit in printed heater ● Poor ground of antenna amplifier or antenna feeder line ● Mirror type film is attached on the rear window glass. ● After-market TV antenna and/or electrical accessories such as radio are attached on the rear window glass.
A cracking or snapping sound occurs while the vehicle is being driven, especially when it is vibrating excessively.	<ul style="list-style-type: none"> ● Malfunction with the ground wire of body parts ● Malfunction with ground due to part installation malfunction. ● Malfunction with wiring connections or a short circuit.

Power Supply Circuit Inspection

AKS002NV

1. CHECK FUSE

- Make sure the following fuses of the BOSE speaker amplifier, audio unit and CD auto changer are not blown. Refer to [PG-62, "FUSE BLOCK - JUNCTION BOX \(J/B\) NO.1"](#) . [PG-64, "FUSE, FUSIBLE LINK AND RELAY BLOCK \(J/B\)"](#) . [PG-65, "FUSE, FUSIBLE LINK AND RELAY BOX"](#) .

Unit	Terminals		Signal name	Fuse No.	
	(+)				(-)
	Connector	Terminal (wire color)			
BOSE speaker amplifier	B233	11(L)	Ground	Battery power	75
	B234	34(L/B)	Ground	ACC power	21
Audio unit	M86	73(SB)	Ground	Battery power	52
	M86	72(L/B)	Ground	ACC power	21
CD auto changer	M109	12(SB)	Ground	Battery power	52
	M109	16(L/OR)	Ground	ACC power	21

OK or NG

OK >> GO TO 2.

NG >> If fuse is blown be sure to eliminate cause of malfunction before installing new fuse. Refer to [PG-2, "POWER SUPPLY ROUTING"](#) .

AUDIO

2. POWER SUPPLY CIRCUIT CHECK

Disconnect the each unit connector. Check voltage between the following harness connector terminal (+) and body ground (-).

Unit	Terminal No.			Power Source	Ignition switch	Reference voltage (V)
	(+)		(-)			
	Connector	Terminal (wire color)				
BOSE speaker amplifier	B233	11 (L)	Ground	Battery power	OFF	Battery voltage
	B234	34 (L/B)	Ground	ACC power	ACC	Battery voltage
Audio unit	M86	73 (SB)	Ground	Battery power	OFF	Battery voltage
	M86	72 (L/B)	Ground	ACC power	ACC	Battery voltage
CD Auto changer	M109	12 (SB)	Ground	Battery power	OFF	Battery voltage
	M109	16 (L/OR)	Ground	ACC power	ACC	Battery voltage

OK or NG

- OK >> Inspection end.
 NG >> Repair or replace harness between each unit and fuse or fusible link.

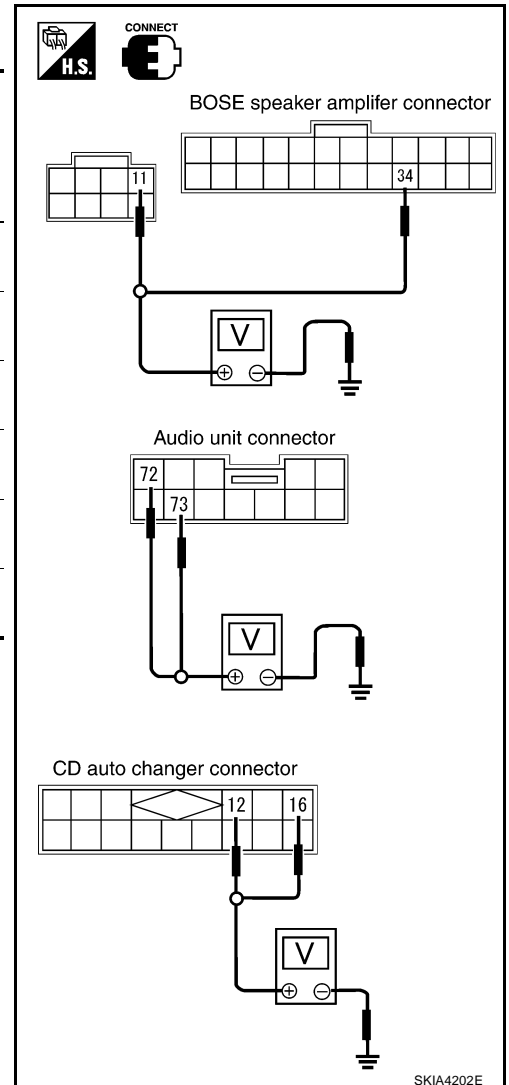

Audio System Does Not Turn On

1. SELF-DIAGNOSIS

1. Perform self-diagnosis. Refer to [AV-69, "Self-Diagnosis Mode"](#) for models with navigation system and [DI-113, "Self-Diagnosis Mode"](#) for models without navigation system.

OK or NG

- OK >> Replace Audio unit.
 NG >> Check the malfunctioned area according to the self-diagnosis result.

Steering Switch Does Not Operate

1. SELF-DIAGNOSIS MODE OF MULTIFUNCTION SWITCH

1. Carry out the self-diagnosis mode in the self-diagnosis function.
2. Push steering switch.

Beep sound should operate.

OK or NG

- OK >> GO TO 2.
 NG >> GO TO 3.

AUDIO

2. SELF-DIAGNOSIS MODE OF AV COMMUNICATION LINE

1. Carry out the self-diagnosis mode in the self-diagnosis function. Refer to [AV-69, "Self-Diagnosis Mode"](#) (with navigation system) or refer to [DI-113, "Self-Diagnosis Mode"](#).

Dose self-diagnosis start?

- YES >> With self-diagnosis results, check the malfunction part.
- NO >> ● Check multifunction switch of power supply and ground circuit check. Refer to [DI-83, "Power Supply and Ground Circuit Inspection for Multifunction Switch"](#). [DI-122, "Inspection of Multifunction Switch for Power Supply and Ground Circuit"](#).
- Check harness between multifunction switch and AV and NAVI control unit or AV control unit.

3. CHECK STEERING SWITCH CIRCUIT

1. Turn the ignition switch OFF.
2. Disconnect steering switch connector and multifunction switch connector.
3. Check the following.
 - Continuity between steering switch harness connector M444 terminal 2 (G) and multifunction switch harness connector M83 terminal 7 (GY/L).
 - Continuity between steering switch harness connector M444 terminal 2 (G) and ground.

Terminals				Continuity
(+) (+)		(-) (-)		
Connector	Terminal (Wire color)	Connector	Terminal (Wire color)	
M444	2 (G)	M83	7 (GY/L)	Yes
M444	2 (G)	Ground		No

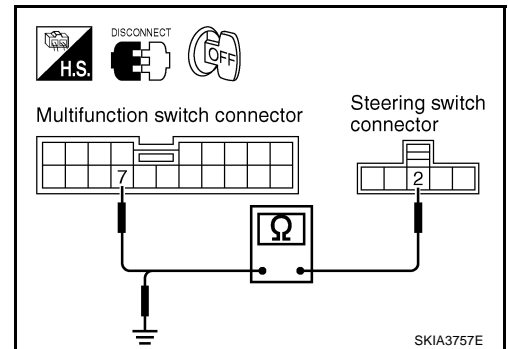

OK or NG

- OK >> GO TO 4.
- NG >> Check the following.
- Harness between for open or short steering switch and spiral cable.
 - Connector housing terminal for disconnection and looseness.

4. CHECK HORN OPERATION

1. Check horn operation.

Horn should operate.

OK or NG

- OK >> GO TO 5.
- NG >> Check horn system.

5. POWER SUPPLY CIRCUIT CHECK

1. Connect steering switch connector.
2. Turn the ignition switch ON.
3. Check harness between steering switch harness connector M444 terminal 1 (R) and ground.

1 (R) - Ground : Battery voltage should exist.

OK or NG

- OK >> GO TO 6
- NG >> Check harness for open or short between steering switch and horn relay [located in fuse, fusible link and relay block (J/B)]

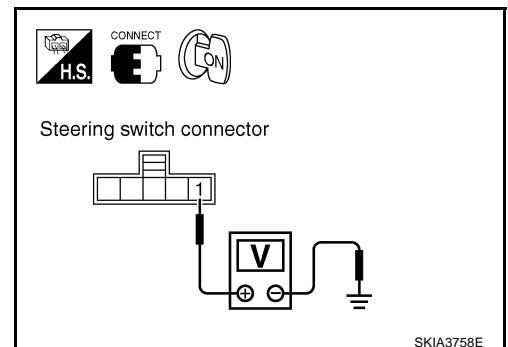

AUDIO

6. STEERING SWITCH GROUND CIRCUIT CHECK

1. Disconnect steering switch connector.
2. Check harness between steering switch harness connector M444 terminal 3(B) and ground.

3 (B) - Ground : Continuity should exist.

OK or NG

- OK >> Replace steering switch.
NG >> Repair or replace harness.

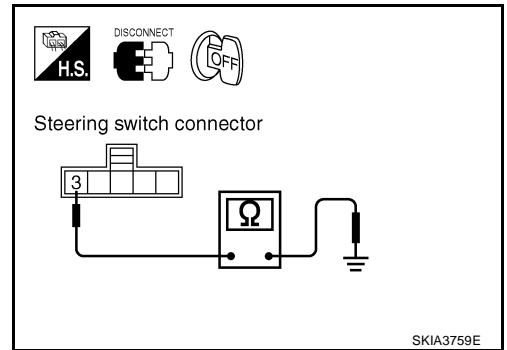

Removal and Installation of Audio Unit REMOVAL

1. Remove glove box assembly. Refer to [IP-11, "Removal and Installation"](#).
2. Remove screws (3), and remove audio unit.

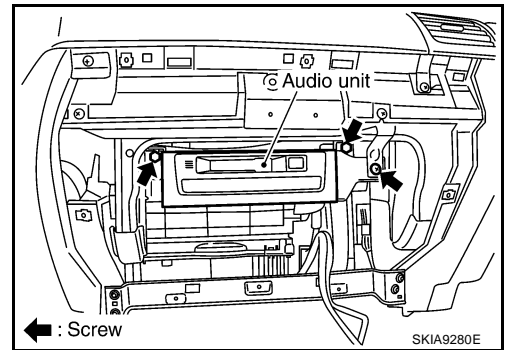

3. Remove screws (4), and remove bracket.

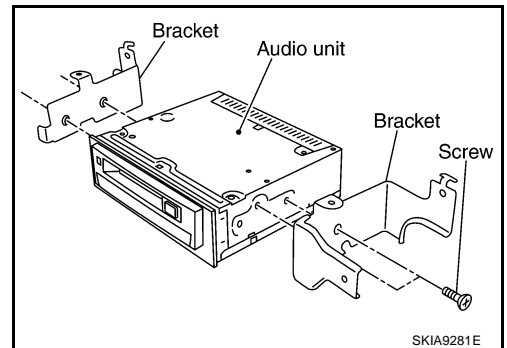

INSTALLATION

Install in the reverse order of removal.

AUDIO

Removal and Installation of CD Auto Changer

AKS00200

REMOVAL

1. Remove console upper finisher. Refer to [IP-10, "Component Parts Drawing"](#) .
2. Remove screws (4), and remove CD auto changer.

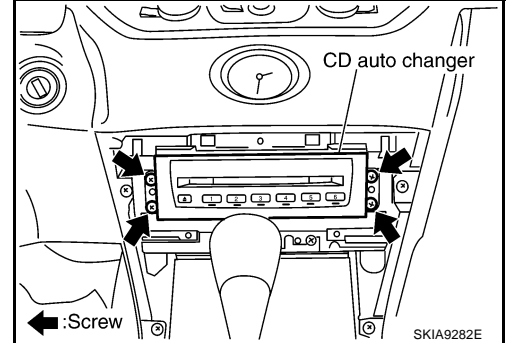

3. Remove screws (4), and remove bracket.

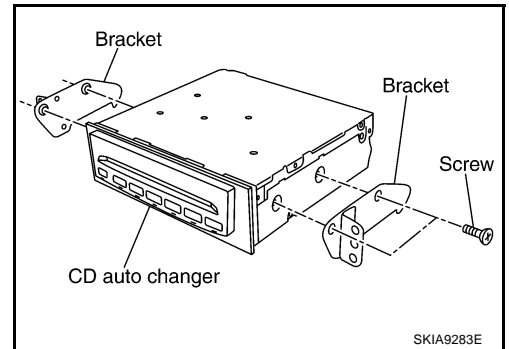

INSTALLATION

Install in the reverse order of removal.

Removal and Installation of Door Speaker

AKS00201

REMOVAL

1. Remove door finisher. Refer to [EI-31, "DOOR FINISHER"](#)
2. Remove screws (3), and remove speaker.

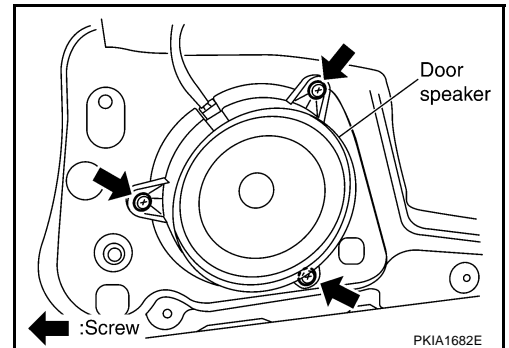

INSTALLATION

Install in the reverse order of removal.

AUDIO

Removal and Installation of Instrument Panel Speaker

AKS002.02

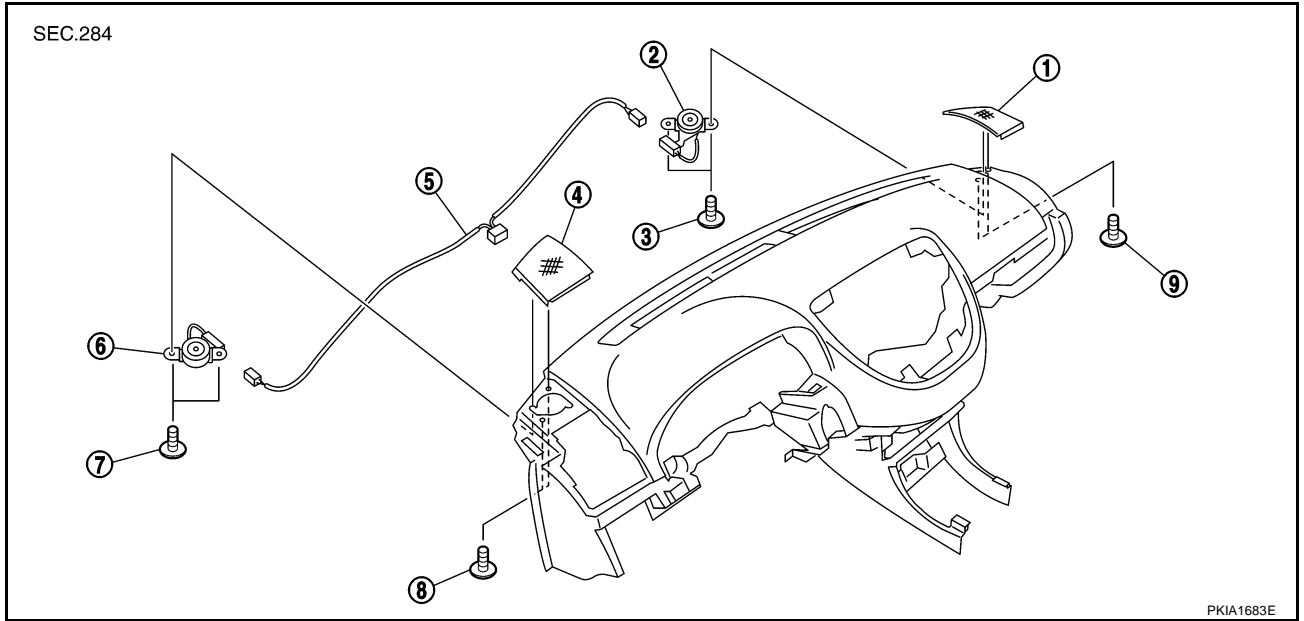

- | | | |
|-------------------|------------------------|-------------------|
| 1. Grille (right) | 2. Speaker (right) | 3. Screws |
| 4. Grille (left) | 5. Speaker sub-harness | 6. Speaker (left) |
| 7. Screws | 8. Screws | 9. Screws |

A
B
C
D
E
F
G
H
I
J
L
M

AV

AUDIO

REMOVAL

1. Remove instrument panel. Refer to [IP-10, "Component Parts Drawing"](#).
2. Remove screws (2), and remove instrument panel speaker.

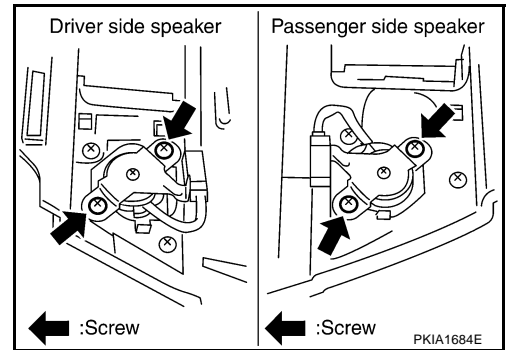

INSTALLATION

Install in the reverse order of removal.

Removal and Installation of Woofer

REMOVAL

1. Remove trunk front finisher, and disconnect woofer harness connector. Refer to [EI-42, "Removal and Installation"](#).
2. Remove rear parcel shelf finisher. Refer to [EI-37, "REAR PARCEL SHELF FINISHER"](#).
3. Remove screws (4), and remove woofer.

AKS00203

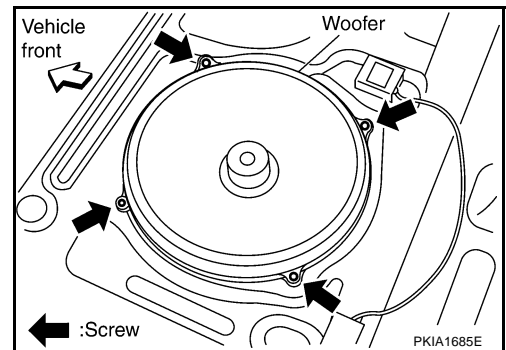

INSTALLATION

Install in the reverse order of removal.

Removal and Installation of BOSE Speaker Amplifier

REMOVAL

1. Remove trunk front finisher. Refer to [EI-42, "Removal and Installation"](#).
2. Remove rear parcel shelf finisher. Refer to [EI-37, "REAR PARCEL SHELF FINISHER"](#).
3. Remove screws (4), and remove BOSE speaker amplifier from the trunk room side.

AKS00204

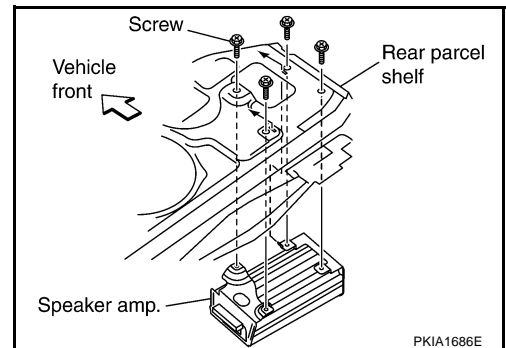

INSTALLATION

Install in the reverse order of removal.

AUDIO

Removal and Installation of Microphone

AKS00ABT

REMOVAL

1. Remove instrument lower driver panel. Refer to [IP-11, "Removal and Installation"](#) .
2. Remove screws (2), and microphone.

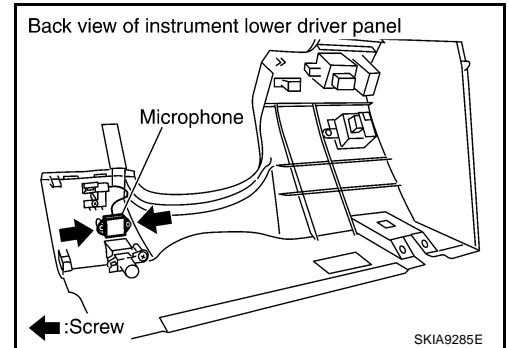

INSTALLATION

Install in the reverse order of removal.

Removal and Installation of Steering Wheel Switch

AKS00205

Refer to [SRS-38, "DRIVER AIR BAG MODULE"](#) .

A
B
C
D
E
F
G
H
I
J
AV
L
M

AUDIO ANTENNA

PFP:28200

AUDIO ANTENNA

Wiring Diagram —W/ANT—

AKS00207

AV-W/ANT-01

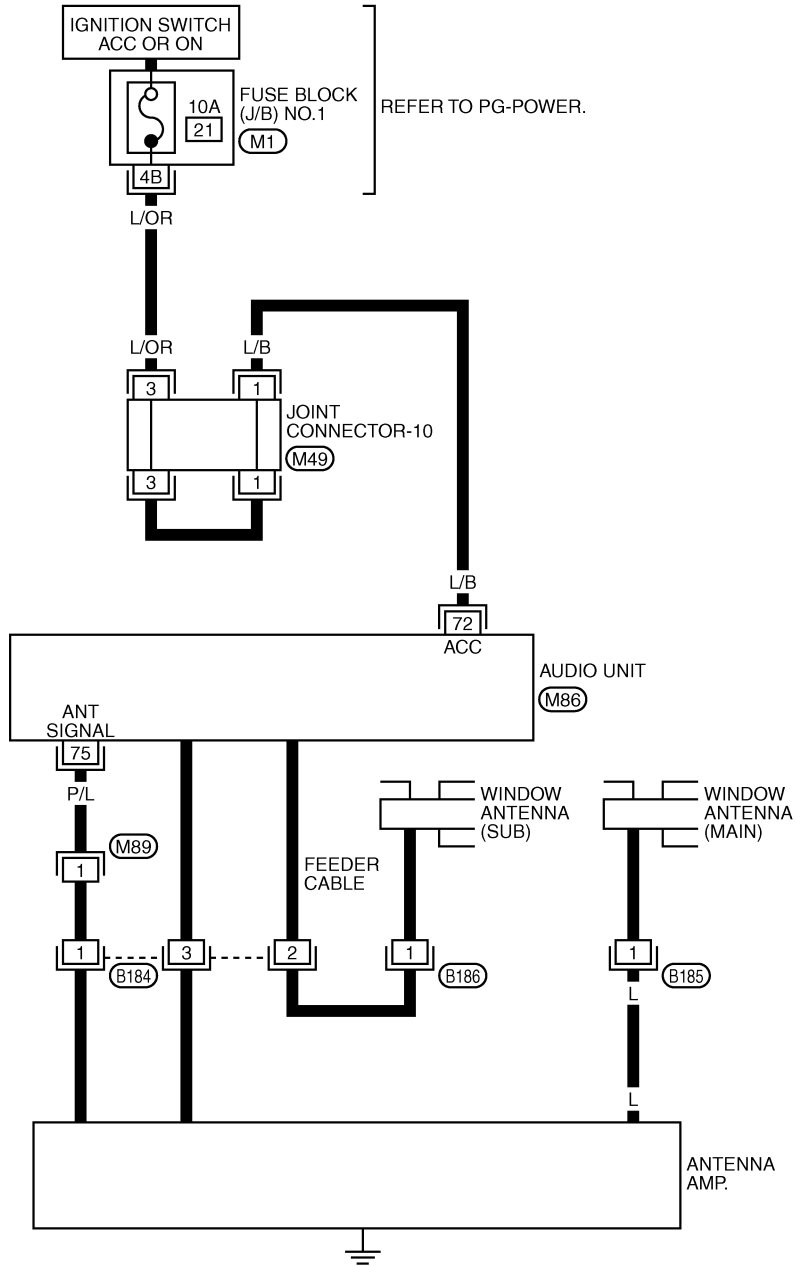

REFER TO PG-POWER.

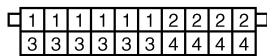

(M49)
L

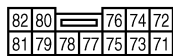

(M86)
W



(M89)
BR

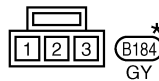

(B184)
GY*

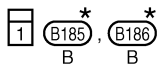

*: THIS CONNECTOR IS NOT SHOWN IN "HARNESS LAYOUT", PG SECTION.

REFER TO THE FOLLOWING.
(M1) - FUSE BLOCK-JUNCTION BOX (J/B) NO.1

AUDIO ANTENNA

Location of Antenna

AKS00208

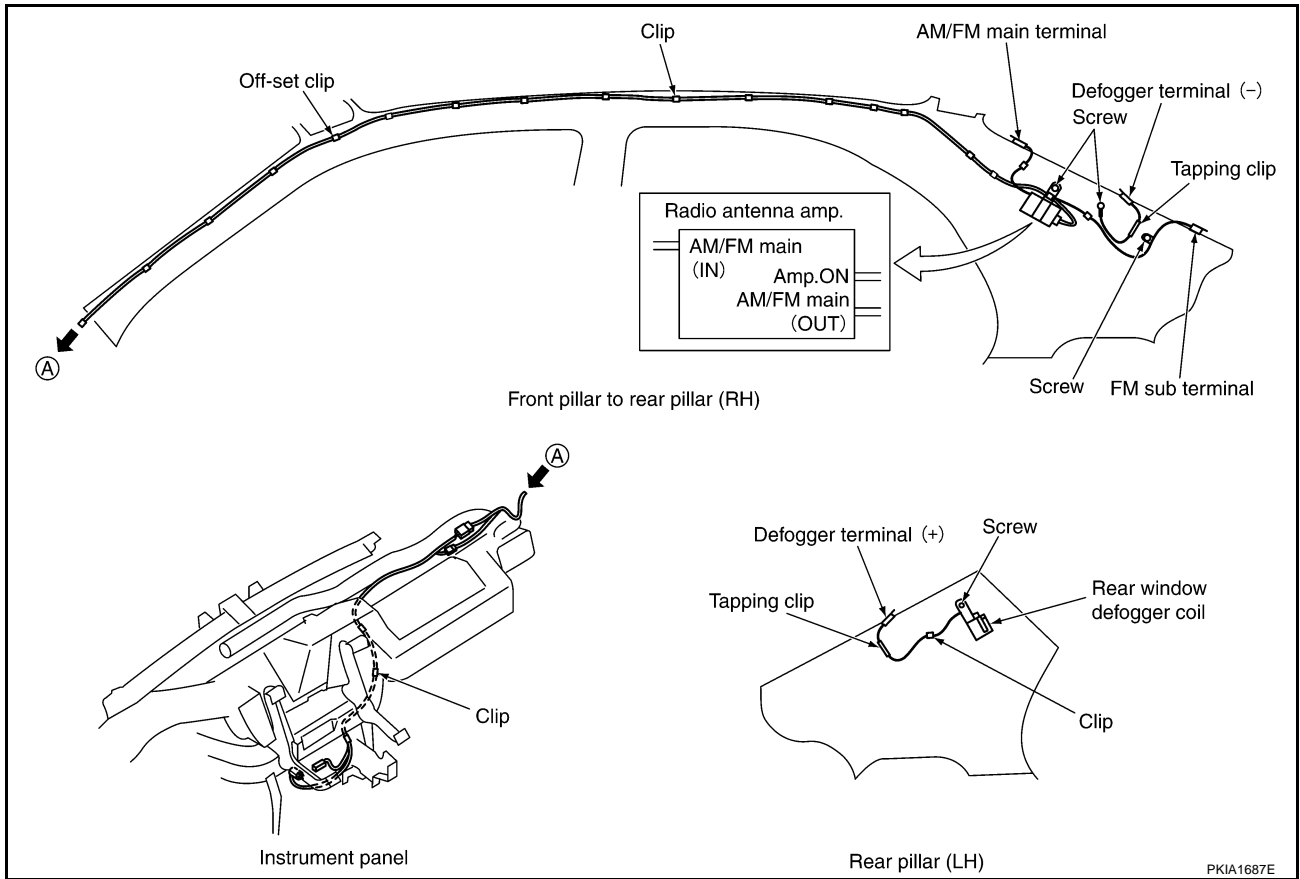

A
B
C
D
E
F
G
H
I

Window Antenna Repair ELEMENT CHECK

AKS00209

1. Attach probe circuit tester (ohm setting) to antenna terminal on each side.

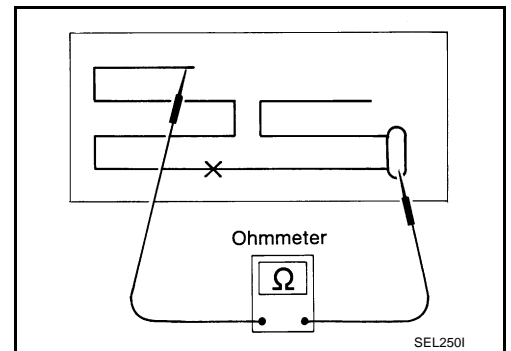

AV
L
M

- When measuring continuity, wrap tin foil around the top of probe. Then, press the foil against the wire with your finger.

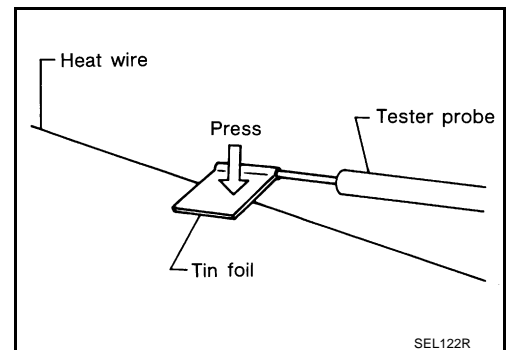

AUDIO ANTENNA

2. If an element is broken, no continuity will exist.

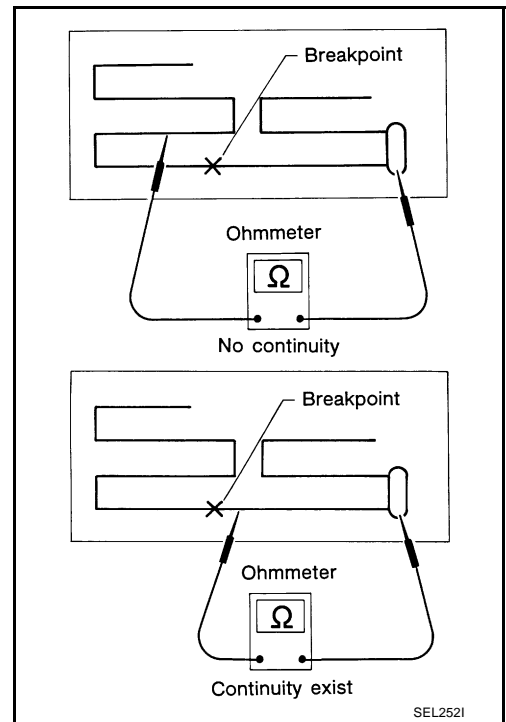

3. To locate a break, move probe along element. Tester needle will swing abruptly when probe passes the broken point.

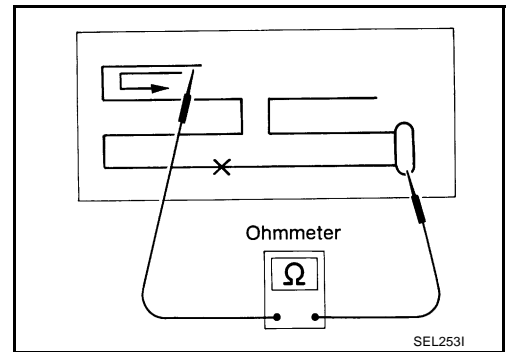

ELEMENT REPAIR

Refer to [GW-76, "Filament Repair"](#) .

TELEPHONE (PRE WIRE)

PFP:28342

A
B
C
D
E
F
G
H
I
J
AV
L
M

TELEPHONE (PRE WIRE) Wiring Diagram — PHONE —

AV-PHONE-01

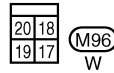
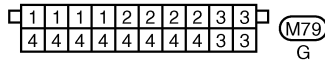
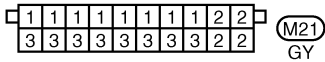
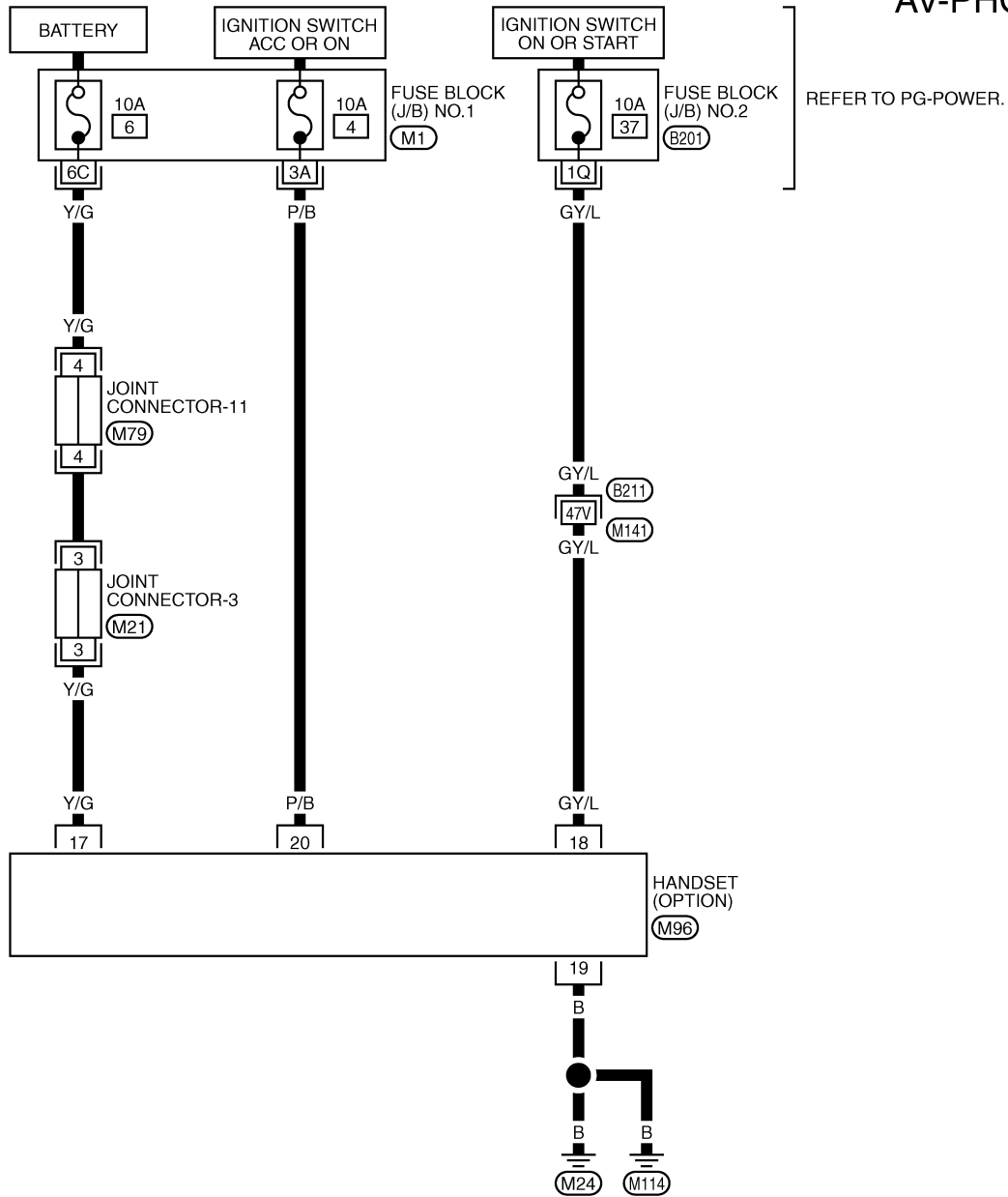

REFER TO THE FOLLOWING.
 (B211) -SUPER MULTIPLE JUNCTION (SMJ)
 (M1) -FUSE BLOCK-JUNCTION BOX (J/B) NO.1
 (B201) -FUSE BLOCK-JUNCTION BOX (J/B) NO.2

NAVIGATION SYSTEM

PFP:25915

System Description

AKS003XC

The navigation system periodically calculates the vehicle's current position according to the following three signals: Travel distance of the vehicle as determined by the vehicle speed sensor, turning angle of the vehicle as determined by the gyroscope (angular velocity sensor), and the direction of vehicle travel as determined by the GPS antenna (GPS information).

The current position of the vehicle is then identified by comparing the calculated vehicle position with map data read from the map DVD-ROM, which is stored in the DVD-ROM drive (map-matching), and indicated on the screen with a current-location mark.

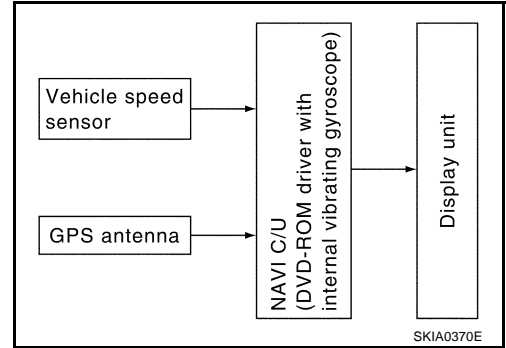

By comparing the vehicle position detection results found by the GPS and by map-matching, more accurate vehicle position data can be used.

The current vehicle position will be calculated by detecting the distance the vehicle moved from the previous calculation point and its direction.

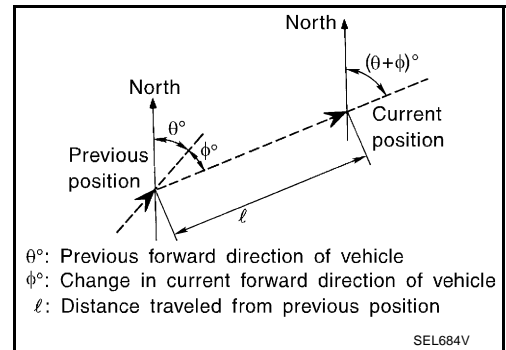

TRAVEL DISTANCE

Travel distance calculations are based on the vehicle speed sensor input signal. Therefore, the calculation may become incorrect as the tires wear down. To prevent this, an automatic distance fine adjustment function has been adopted.

TRAVEL DIRECTION

Change in the travel direction of the vehicle is calculated by a gyroscope (angular velocity sensor) and a GPS antenna (GPS information). As the gyroscope and GPS antenna have both merit and demerit, input signals from them are prioritized in each situation. However, this order of priority may change in accordance with more detailed travel conditions so that the travel direction is detected more accurately.

Type	Advantage	Disadvantage
Gyroscope (angular velocity sensor)	<ul style="list-style-type: none"> Can detect the vehicle's turning angle quite accurately. 	<ul style="list-style-type: none"> Direction errors may accumulate when the vehicle is driven for long distances without stopping.
GPS antenna (GPS information)	<ul style="list-style-type: none"> Can detect the vehicle's travel direction (North/South/East/West). 	<ul style="list-style-type: none"> Correct direction cannot be detected when the vehicle speed is low.

MAP-MATCHING

Map-matching is a function that repositions the vehicle on the road map when a new location is judged to be the most accurate. This is done by comparing the current vehicle position, calculated by the method described in the position detection principle, with the road map data around the vehicle, read from the map DVD-ROM stored in the DVD-ROM drive.

Therefore, the vehicle position may not be corrected after the vehicle is driven over a certain distance or time in which GPS information is hard to receive. In this case, the current-location mark on the display must be corrected manually.

CAUTION:

The road map data is based on data stored in the map DVD-ROM.

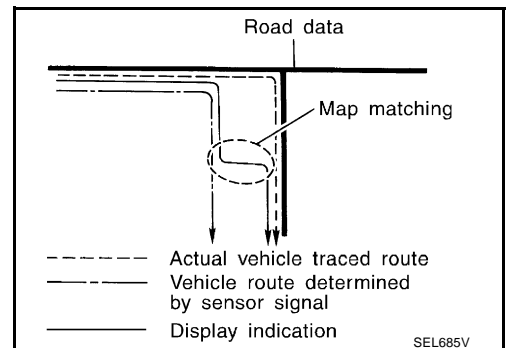

NAVIGATION SYSTEM

- In map-matching, alternative routes to reach the destination will be shown and prioritized, after the road on which the vehicle is currently driven has been judged and the current-location mark has been repositioned.
If there is an error in distance and/or direction, the alternative routes will be shown in different order of priority, and the wrong road can be avoided.
If two roads are running in parallel, they are of the same priority. Therefore, the current-location mark may appear on either of them alternately, depending on maneuvering of the steering wheel and configuration of the road.

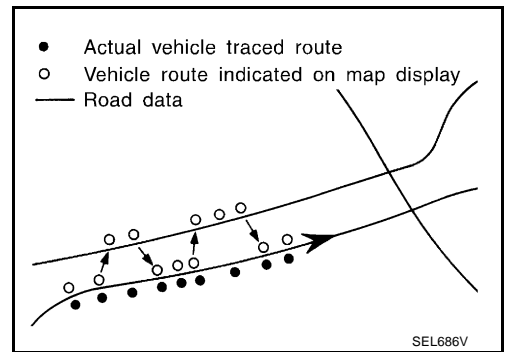

- Map-matching does not function correctly when the road on which the vehicle is driving is new and not recorded in the map DVD-ROM, or when the road pattern stored in the map data and the actual road pattern are different due to repair.
When driving on a road not present in the map, the map-matching function may find another road and position the current-location mark on it. Then, when the correct road is detected, the current-location mark may leap to it.
- Effective range for comparing the vehicle position and travel direction calculated by the distance and direction with the road data read from the map DVD-ROM is limited. Therefore, when there is an excessive gap between the current vehicle position and the position on the map, correction by map-matching is not possible.

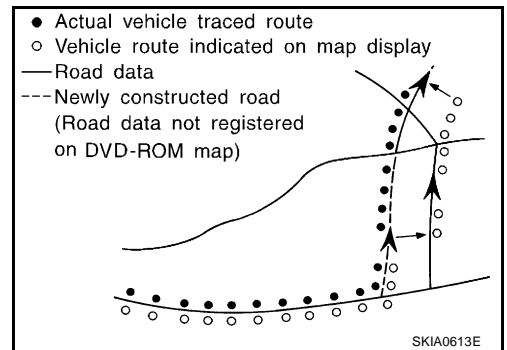

GPS (GLOBAL POSITIONING SYSTEM)

GPS (Global Positioning System) has been developed and controlled by the US Department of Defense. The system utilizes GPS satellite (NAVSTAR), sending out radio waves while flying on an orbit around the earth at the height of approx. 21,000 km (13,000 miles). The GPS receiver calculates the vehicle's position in three dimensions (latitude/longitude/altitude) according to the time lag of the radio waves received from four or more GPS satellites (three-dimensional positioning). If radio waves were received only from three GPS satellites, the GPS receiver calculates the vehicle's position in two dimensions (latitude/longitude), utilizing the altitude data calculated previously by using radio waves from four or more GPS satellites (two-dimensional positioning).

Accuracy of the GPS will deteriorate under the following conditions.

- In two-dimensional positioning, the GPS accuracy will deteriorate when the altitude of the vehicle position changes.
- There may be an error of approximately 10 m(30 ft) in position detected by three-dimensional positioning, which is more accurate than two-dimensional positioning. The accuracy can be even lower depending on the arrangement of the GPS satellites utilized for the positioning.
- Position detection is not possible when the vehicle is in an area where radio waves from the GPS satellite do not reach, such as in a tunnel, parking lot in a building, and under an elevated highway. Radio waves from the GPS satellites may not be received when some object is located over the GPS antenna.
- Position correction by GPS is not available while the vehicle is stopped.

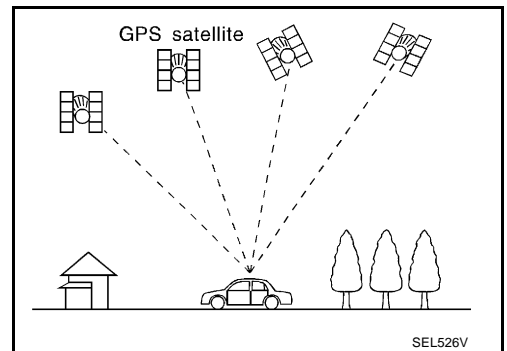

NAVIGATION SYSTEM

COMPONENT DESCRIPTION

AV and NAVI Control Unit

- The gyro (angular speed sensor) and the DVD-ROM drive are built-in units that control the navigation functions.
- Signals are received from the gyro, the vehicle speed sensor, and the GPS antenna. Vehicle location is determined by combining this data with the data contained in the DVD-ROM map. Locational information is shown on liquid crystal display panel.

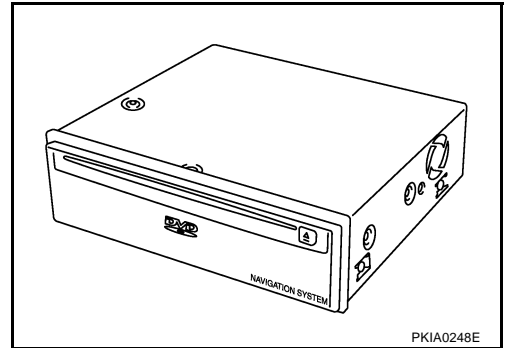

DVD-ROM Drive

Maps, traffic control regulations, and other pertinent information can be easily read from the DVD-ROM disc.

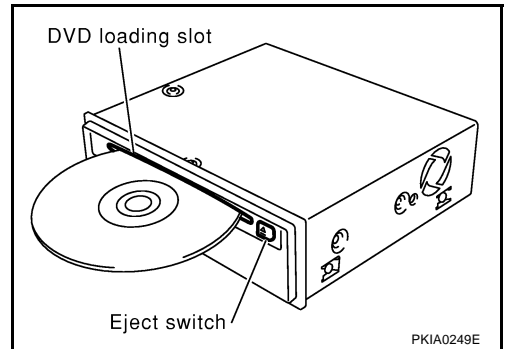

Map DVD-ROM

- The map DVD-ROM has maps, traffic control regulations, and other pertinent information.
- To improve DVD-ROM map matching and route determination functions, the DVD-ROM uses an exclusive Nissan format. Therefore, the use of a DVD-ROM provided by other manufacturers cannot be used.

Gyro (Angular Speed Sensor)

- The oscillator gyro sensor is used to detect changes in vehicle steering angle.
- The gyro is built into the navigation (NAVI) control unit.

BIRDVIEW™

The BIRDVIEW™ provides a detailed and easily seen display of road conditions covering the vehicle's immediate to distant area.

- MAP DISPLAY

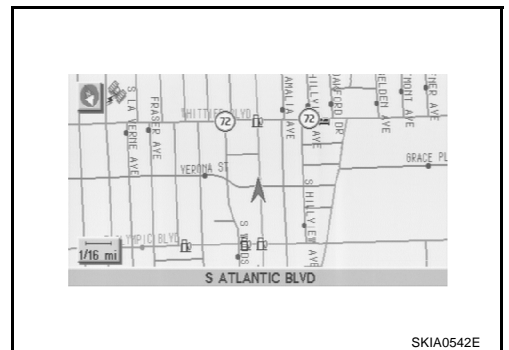

NAVIGATION SYSTEM

- BIRDVIEW™

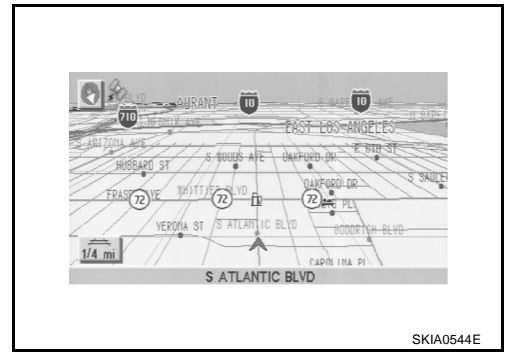

Description

- Display area: Trapezoidal representation showing approximate distances (W_n , D , and W_d).
- Ten horizontal grid lines indicate display width while six vertical grid lines indicate display depth and direction.
- Drawing line area shows open space, depth, and immediate front area. Each area is to a scale of approximately 5:6:25.
- Pushing the “ZOOM IN” button during operation displays the scale change and the view point height on the left side of the screen.
The height of the view point increases or decreases when “ZOOM” or “WIDE” is selected with the joystick.

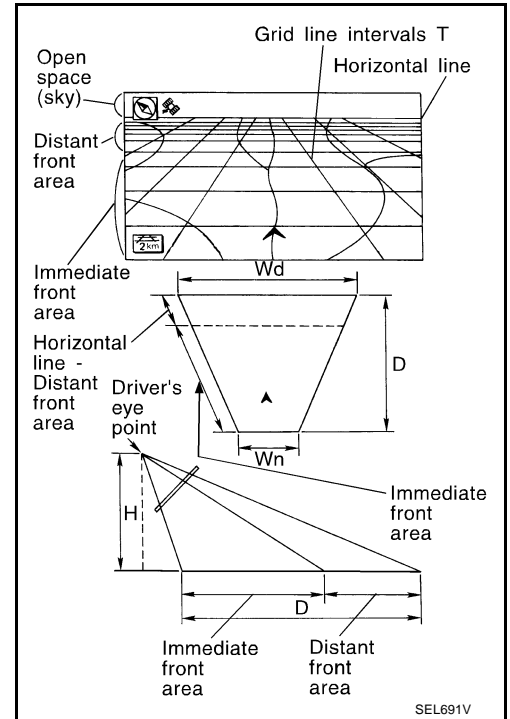

MAP DISPLAY

Function of each icon is as follows:

1. Azimuth indication.
2. Position marker.
 - The tip of the arrow shows the current position. The shaft of the arrow indicates the direction in which the vehicle is traveling.
3. GPS reception signal (indicates current reception conditions).
4. Distance display (shows the distance in a reduced scale).

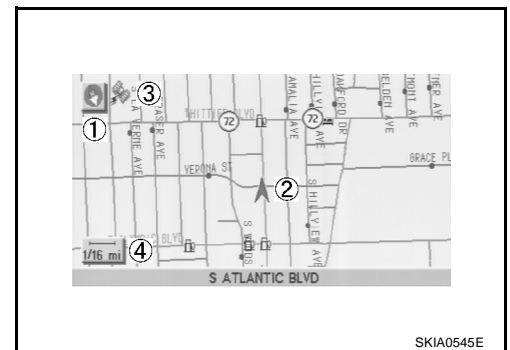

A
B
C
D
E
F
G
H
I
J
K
L
M

AV

NAVIGATION SYSTEM

FUNCTION OF MULTIFUNCTION SWITCH

Display with Pushed "DEST" Switch

- Easy Mode

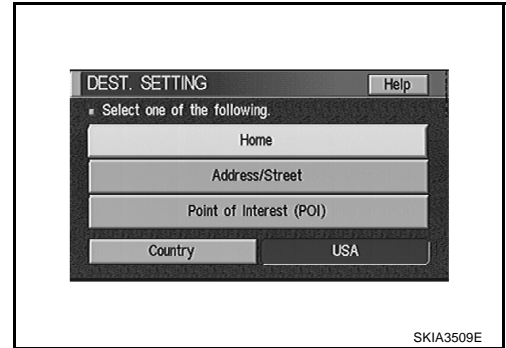

- Expert Mode

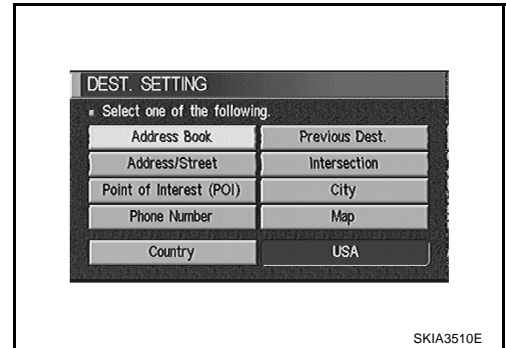

The function of each icon is as follows:

Icon	MODE		Description
	Easy	Expert	
Address Book		×	Favorite place can be saved to memory.
Address/Street	×	×	The destination can be searched from the address.
Point of Interest (POI)	×	×	The destination of favorite facility can be searched.
Phone Number		×	When two or more countries are included in one DVD-ROM, the destination can be searched for under the country name.
Previous Dest.		×	The previous ten destinations stored in memory are displayed.
Intersection		×	The destination can be searched from the intersection.
City		×	The destination can be searched from city name.
Map		×	The destination can be searched from the map.
Home	×		Sets the home as a destination.
Help	×		Explanation of navigational functions appear on the display.
Country	×	×	Select country (USA, CANADA)

NAVIGATION SYSTEM

Display with Pushed "ROUTE" Switch

- Easy Mode

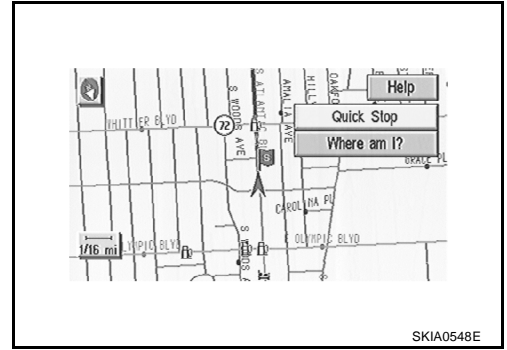

- Expert Mode

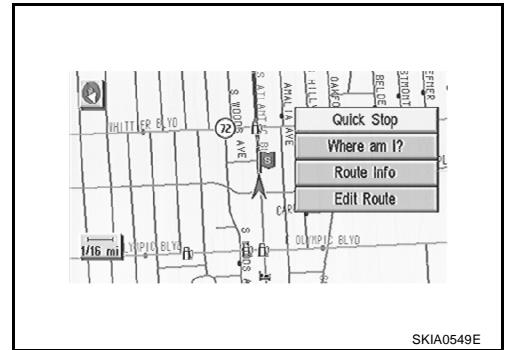

The function of each icon is as follows:

Icon	MODE		Description
	Easy	Expert	
Quick Stop	×	×	The selected facility is set as the destination or waypoint. (Route guidance has been turned OFF or the destination has been reached)
Where am I?	×	×	Next, current and previous street names can be displayed.
Route Info.*		×	The following items can be set. <ul style="list-style-type: none"> ● Complete Route ● Turn List ● Route Simulation (Displayed only when the destination area has been set.)
Edit Route*		×	Change the destination or add the transit points of the route set in the route guide. (Displayed only when the automatic reroute function has been turned OFF and the recommended route is not followed.)
Help	×		Explanation of navigational functions appear on the display.

*: When destinations have been entered, route guidance has been turned OFF or destination has been reached, "Route Info." and "Edit Route" are not displayed.

NAVIGATION SYSTEM

Display with Pushed “SETTING” Switch

The function of each icon is as follows:

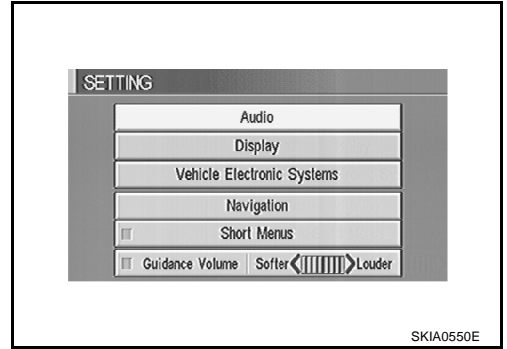

Icon	Description
Audio	Sound quality can be adjusted, and also ON/OFF setting of switch beep sound can be performed. Noise compensation ON/OFF setting can be performed.
Display	Settings of display can be performed.
Vehicle Electronic Systems	Settings of vehicle electrical equipment can be performed.
Navigation	Settings and adjusting of navigation can be performed.
Short Menus	Easy Mode and Expert Mode can be switched.
Guidance Volume	The volume and/or on/off of voice prompt can be controlled by the joystick.
Help (only easy mode)	Explanation of navigational functions appear on the display.

NAVIGATION SYSTEM

Navigation Setting

How To Perform Navigation Setting

1. Start the engine.
2. Push "SETTING" switch.
3. Select "NAVIGATION".

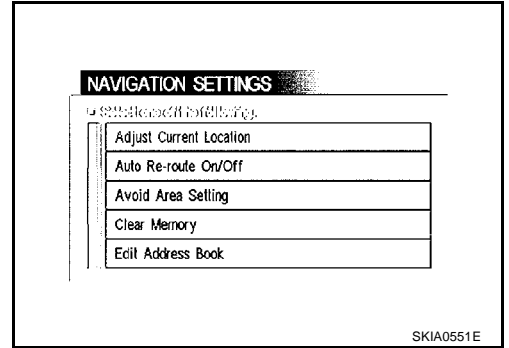

Application Items

Icon	Description	Reference page
View	Map display mode can be switched.	AV-45
Heading	Heading of the map display can be customized for either north heading or the actual driving direction of the vehicle.	AV-47
Nearby Display Icons	Icons of facilities can be displayed. Facilities to be displayed can be selected from the variety selections.	AV-48
Save Current Location	Current vehicle location can be registered in Address Book.	AV-46
Adjust Current Location	Current location of position marker can be adjusted. Direction of position marker also can be calibrated when heading direction of the vehicle on the display is not matched with the actual direction.	AV-48
Auto Re-route ON/OFF	ON/OFF of Auto Re-route can be switched.	AV-46
Avoid Area Setting	A particular area can be avoided when routing.	AV-47
Clear Memory	Address book, previous destination or avoid area can be deleted.	AV-49
Edit Address Book	Address book can be edited.	AV-47
GPS Information	The GPS data includes longitude, latitude and altitude (distance above sea level) of the present vehicle position, and current date and time for the area in which the vehicle is being driven. Also indicated are the GPS reception conditions and the GPS satellite position.	AV-46
Quick Stop Customer Setting	One facility of your selection can be added to your Quick Stop.	AV-46
Set Average Speed for Estimated Journey Time	Average vehicle speed can be set to calibrate estimated journey time for the destination.	AV-48
Tracking	Tracking to the present vehicle position can be displayed.	AV-47

"VIEW" MODE

1. Select "BIRDVIEW™" or "Plan View" icon.
 - To open the map screen display with BIRDVIEW™, select "BIRDVIEW™".
 - To open the map screen display with Plan View, select "Plan View".

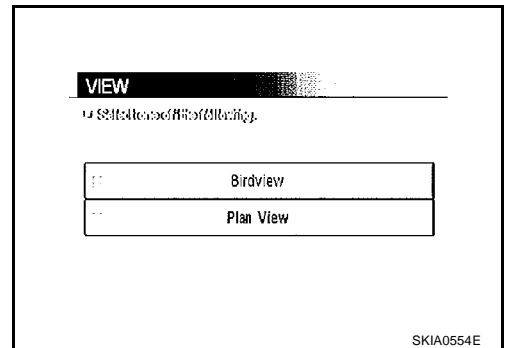

NAVIGATION SYSTEM

“GPS INFORMATION” MODE

- Latitude, longitude, altitude, astrometric state, and satellite location are displayed as GPS information.

NOTE:

Altitude is displayed only in three-dimensional status.

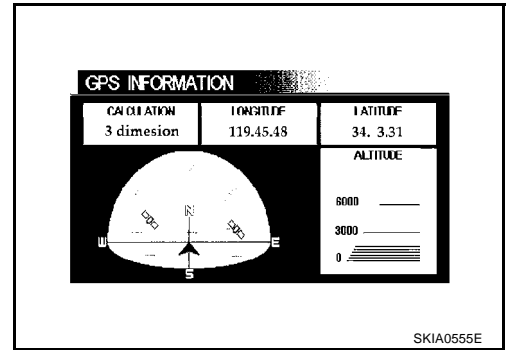

“SAVE CURRENT LOCATION” MODE

- The current vehicle location can be registered in “Address Book”.

NOTE:

“Address Book” can store 50 items max.

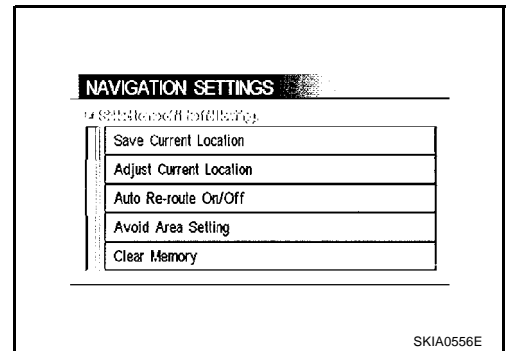

“QUICK STOP CUSTOMER SETTINGS” MODE

- Select a category for the “Quick Stop” menu.

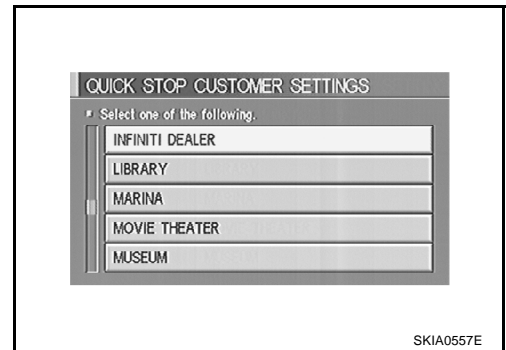

“AUTO RE-ROUTE” MODE

- To activate “AUTO RE-ROUTE” mode, select “On”.
- To deactivate “AUTO RE-ROUTE” mode, select “Off”.

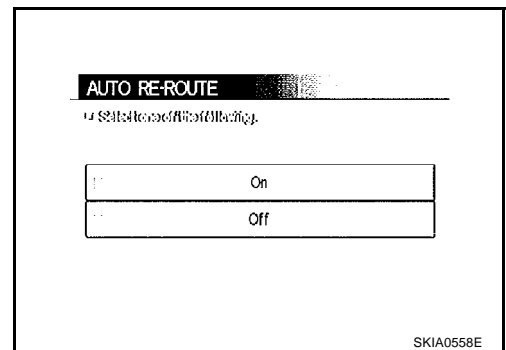

NAVIGATION SYSTEM

“AVOID AREA SETTINGS” MODE

- Areas to avoid can be registered.

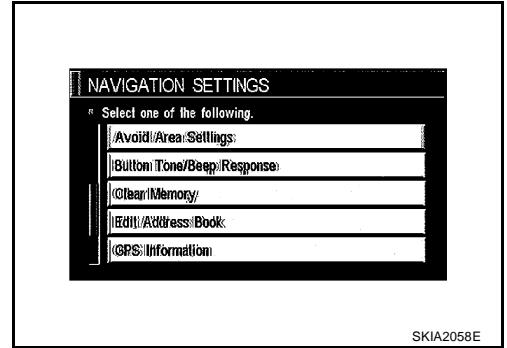

A
B
C
D

“TRACKING” MODE

- To delete the tracking marks on, select “Off”.
- To leave the tracking marks on map, select “On”.

NOTE:

When a trail display is turned OFF, trail data is erased from the memory.

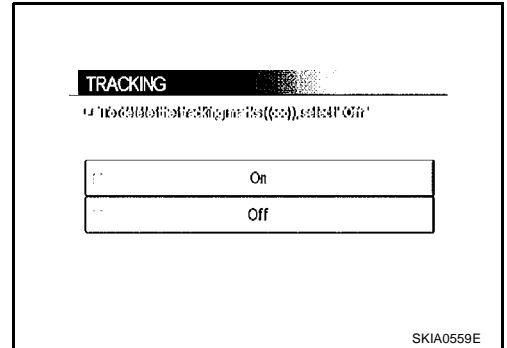

E
F
G
H

“EDIT ADDRESS BOOK” MODE

- Edit the items registered in Address Book.

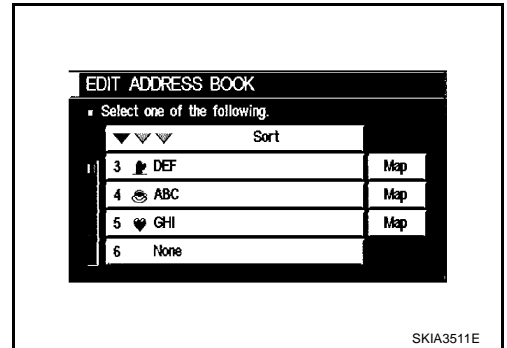

I
J
AV
L

“HEADING” MODE

- To display North up, select “North up”.
- To display the car heading up, select “Heading up”.

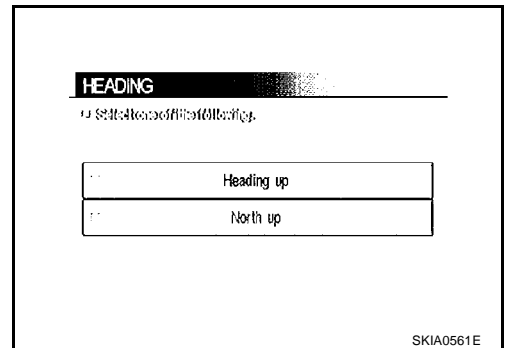

M

NAVIGATION SYSTEM

“NEARBY DISPLAY ICONS” MODE

- Select an icon to display on the map screen.

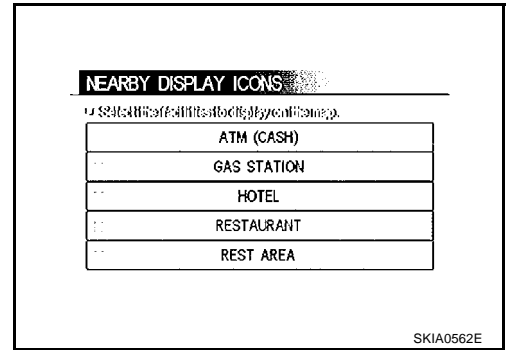

“ADJUST CURRENT LOCATION” MODE

1. Select an icon “right” or “left” to calibrate the heading direction. (Arrow marks will rotate corresponding to the calibration key.)

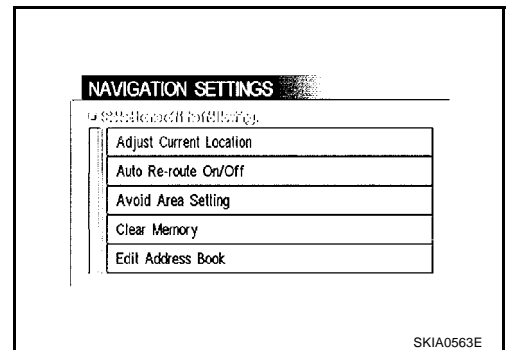

2. Select “Set”. Then the vehicle mark will be matched to the arrow mark.

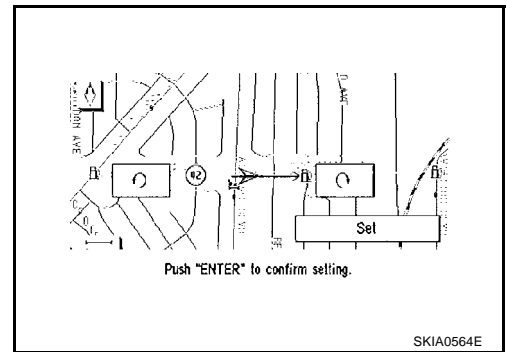

“SET AVERAGE SPEED” MODE

- Set the average vehicle speed to calibrate the estimated journey time for the destination.
- Set three items; “Freeway”, “Main Roads”, and “Ordinary Roads”.

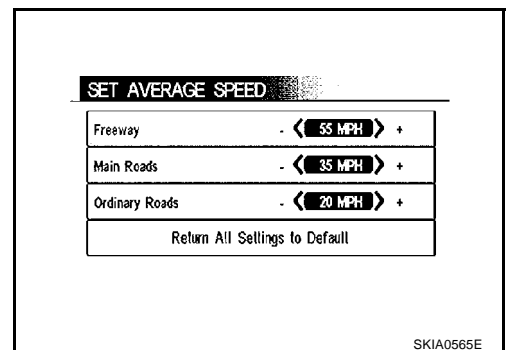

NAVIGATION SYSTEM

“CLEAR MEMORY” MODE

- To delete all the stored places in “Address Book”, “Avoid Area” and “Previous Dest”, select “Yes”.

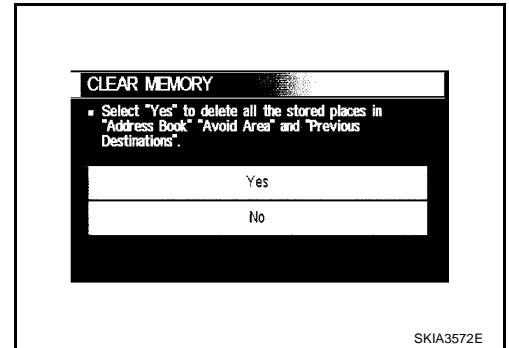

GUIDANCE VOLUME

Description

Following guidance volume setting can be changed.

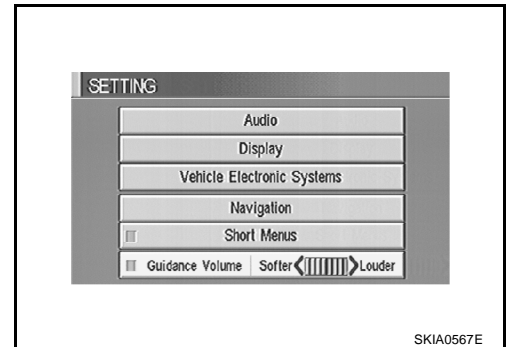

Activation/Deactivation Setting

- The voice prompt can be turned on/off by pressing the “Guidance Volume” button.

Voice Volume Setting

- Volume of the voice can be controlled by bending the joystick to left/right.

Precautions for AV and NAVI Control Unit Replacement

AKS003XD

- When replacing the AV and NAVI control unit, eject the map DVD-ROM before disconnecting the battery.
- The AV and NAVI control unit has the following information stored in its memory. Record the memory contents before replacing the control unit, and input them in the new unit as necessary.

<FM-AM>

- Preset frequency
- Area for indicating station, selection of overlapped stations

<CD>

- Program status

<Sound quality>

- Volume balance memory set values
- Equalizer memory set values

<Image quality>

- Brightness of light when ON/OFF
- Dimming switching
- Display color switching

<Navigation mode>

- Latest status (map screen/BIRDVIEW™, reduced scale, rotation angle of map screen, route guide ON/OFF, track ON/OFF, etc.)
- Current position
- Destination, passing point 1 - 5
- Registered places, their names, etc.

NOTE:

Only removing the battery does not erase the memory.

NAVIGATION SYSTEM

Component Parts Location

AKS0020D

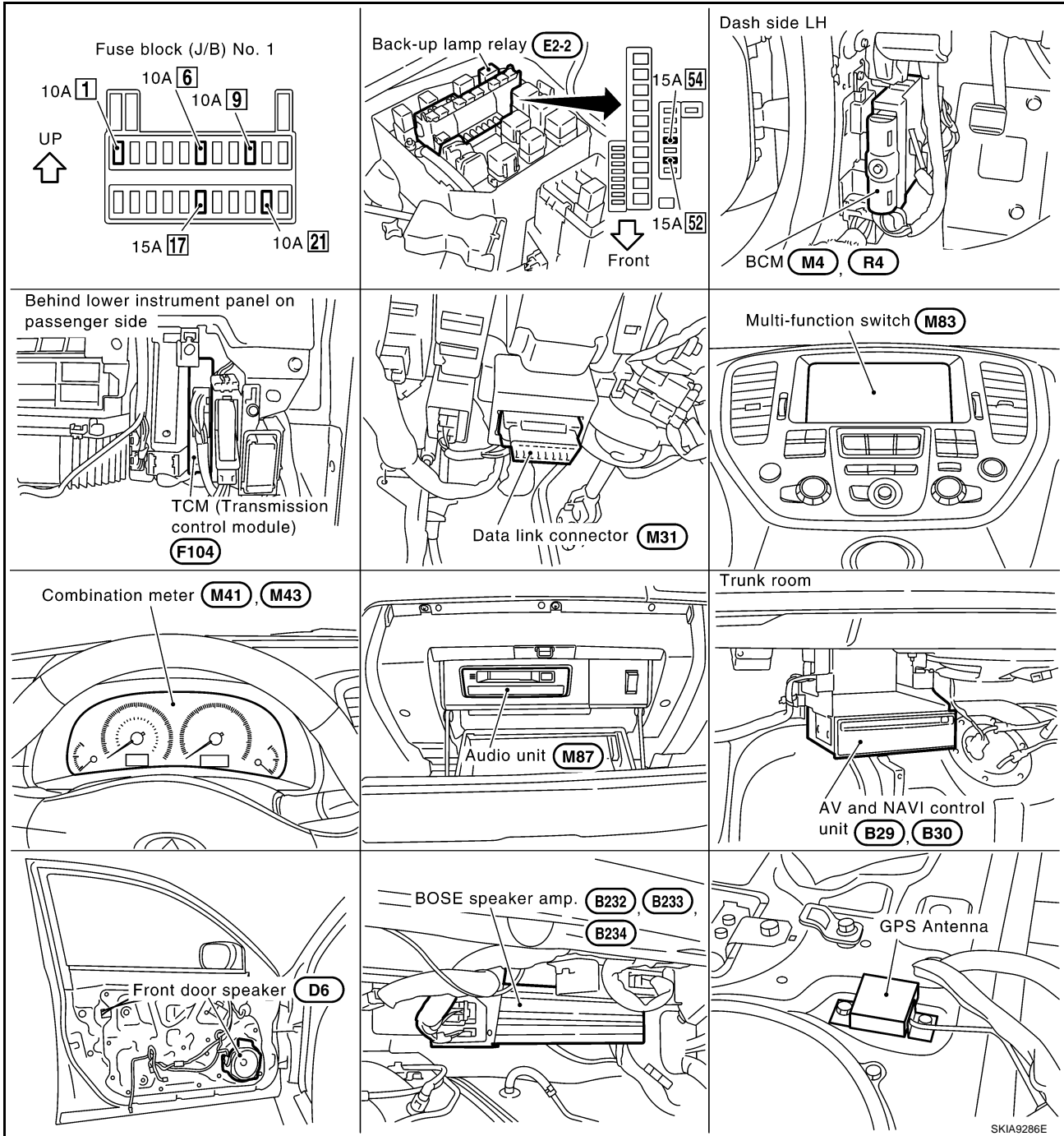

Location of Antenna

AKS0020E

Refer to [AV-35, "Location of Antenna"](#).

NAVIGATION SYSTEM

Schematic

AKS003XE

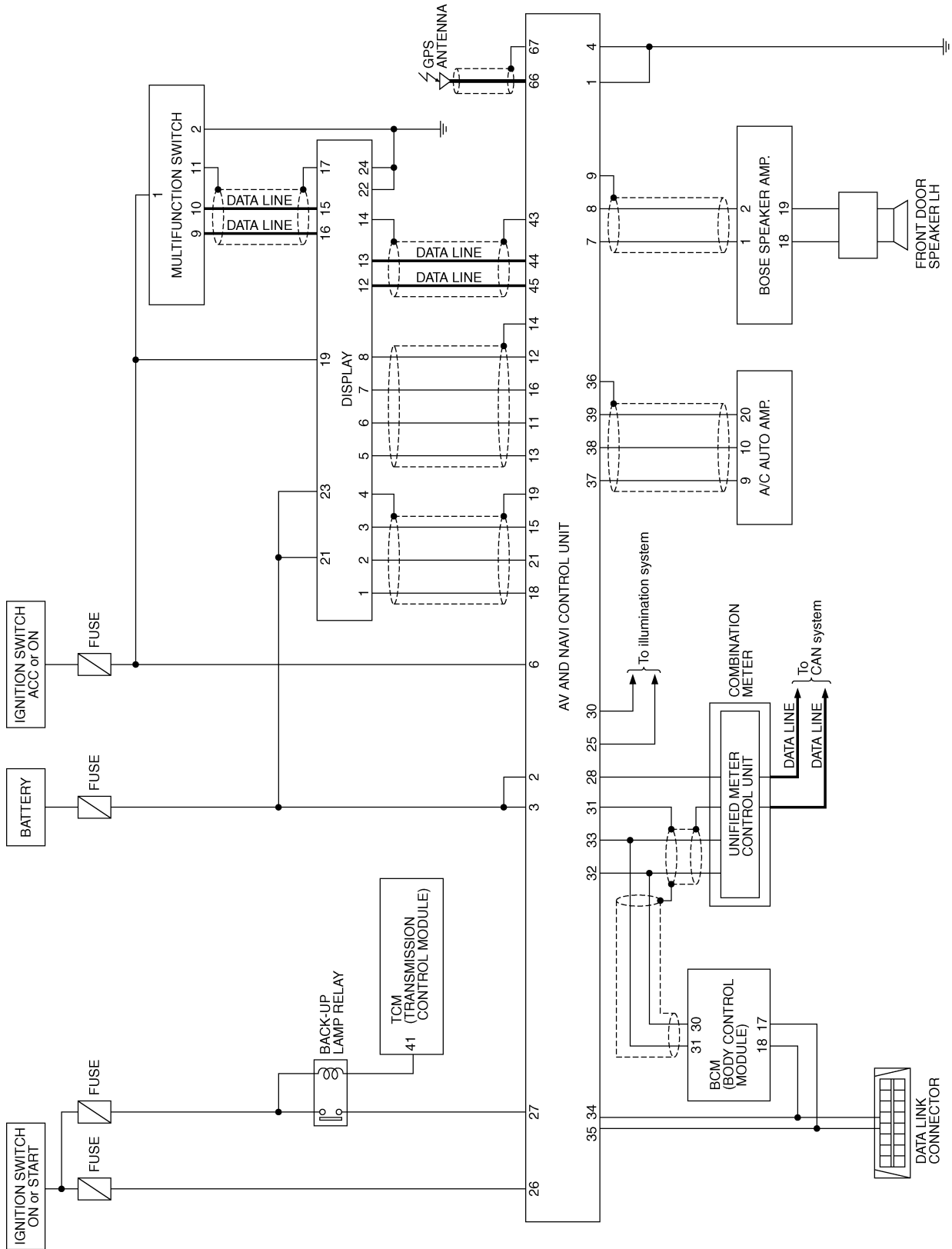

A
B
C
D
E
F
G
H
I
J
AV
L
M

NAVIGATION SYSTEM

Wiring Diagram —NAVI—

AKS003XF

AV-NAVI-01

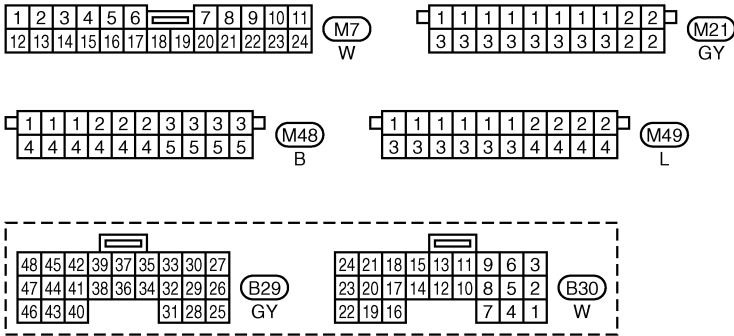
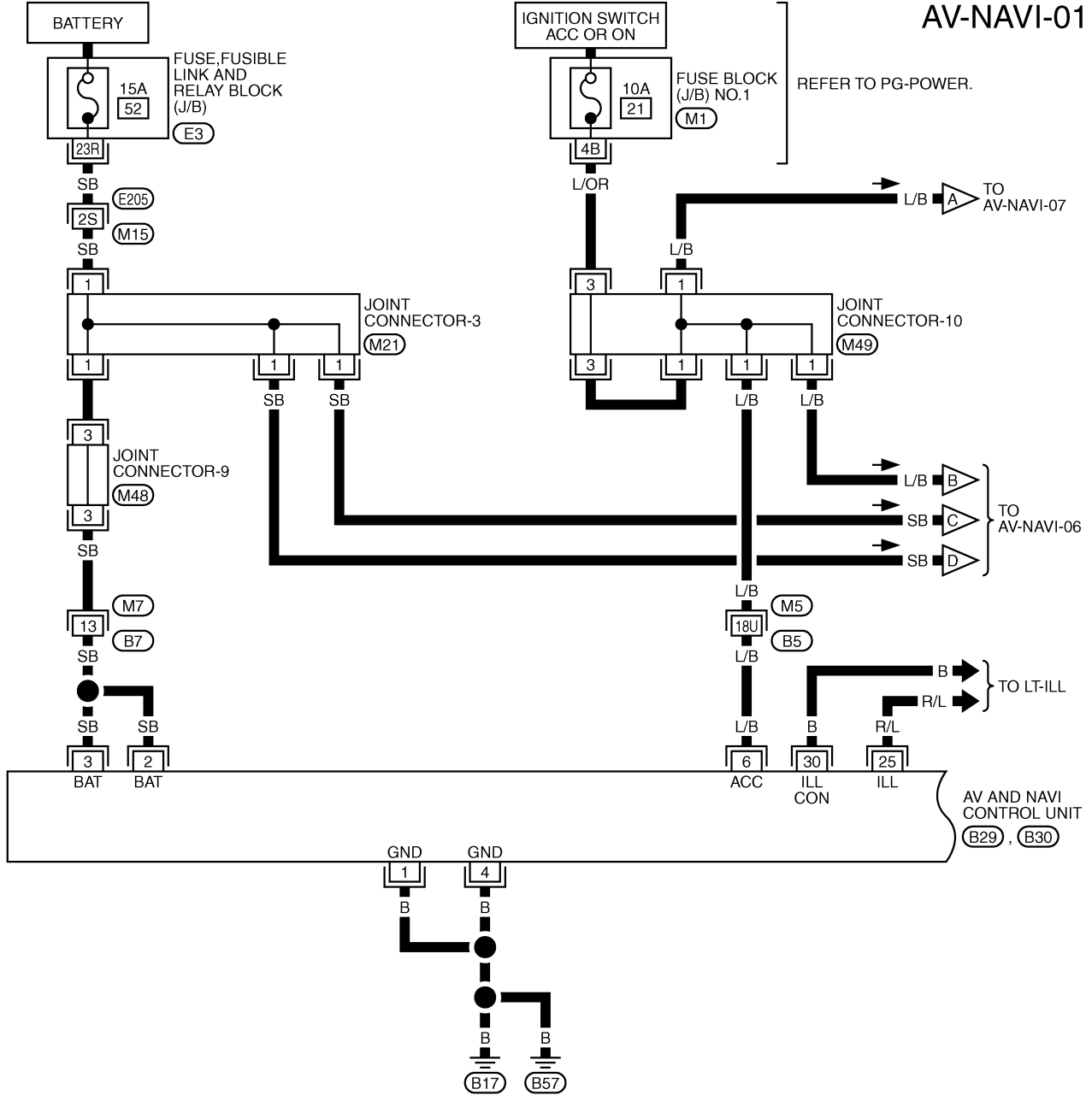

REFER TO THE FOLLOWING.

- (M5), (E205) -SUPER MULTIPLE JUNCTION (SMJ)
- (M1) -FUSE BLOCK-JUNCTION BOX (J/B) NO.1
- (E3) -FUSE,FUSIBLE LINK AND RELAY BLOCK (J/B)

TKWA1246E

NAVIGATION SYSTEM

AV-NAVI-02

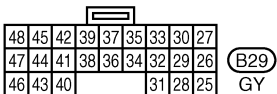
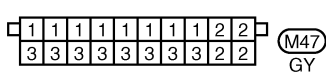
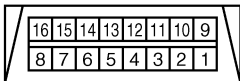
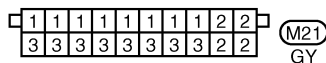
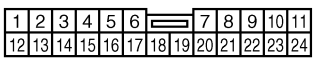
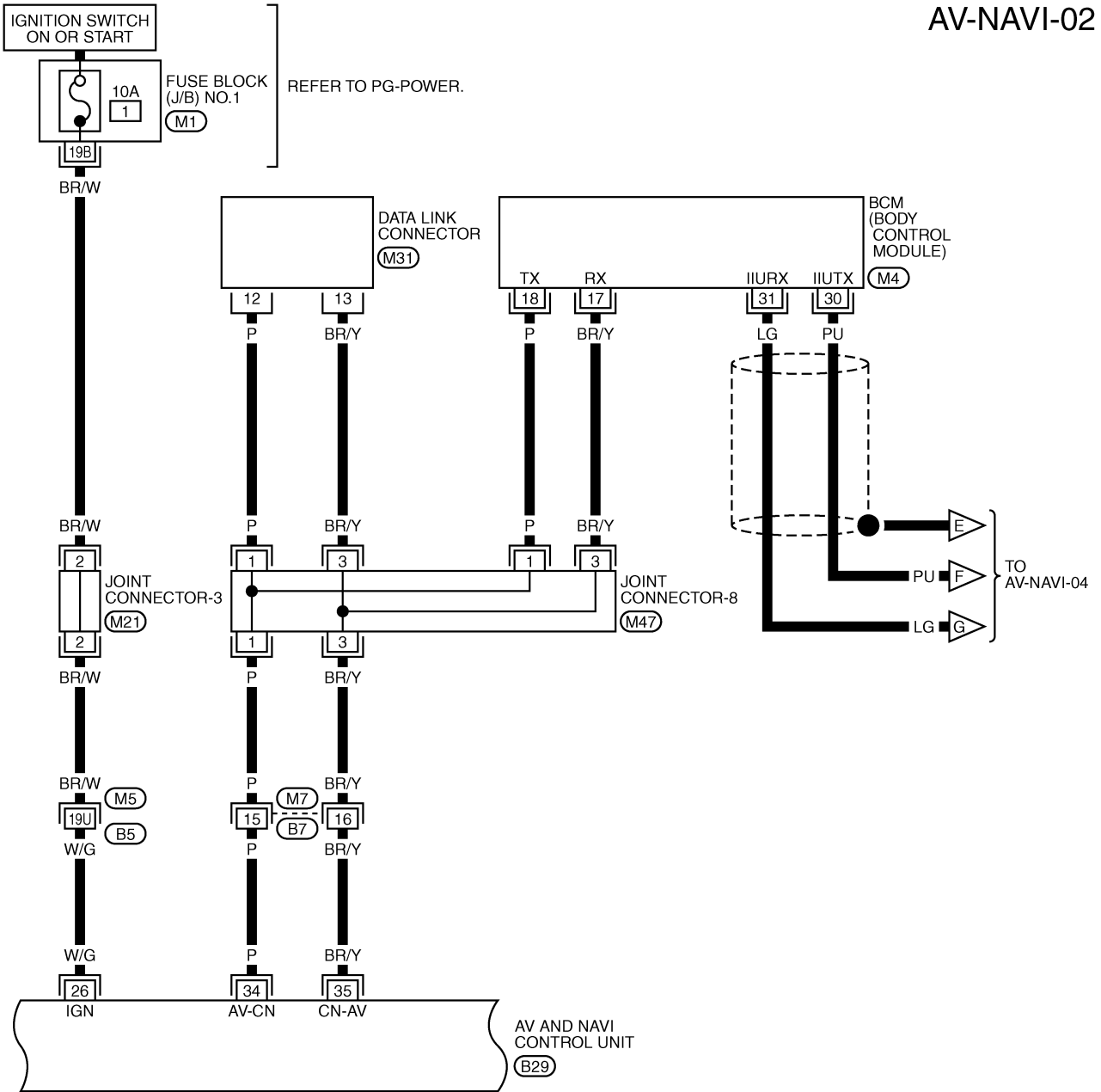

REFER TO THE FOLLOWING.

- (M5) -SUPER MULTIPLE JUNCTION (SMJ)
- (M1) -FUSE BLOCK-JUNCTION BOX (J/B) NO.1
- (M4) -ELECTRICAL UNITS

TKWA0661E

NAVIGATION SYSTEM

AV-NAVI-03

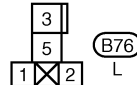
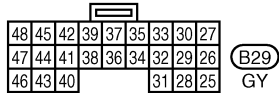
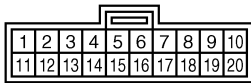
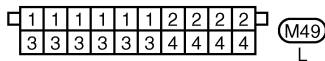
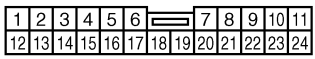
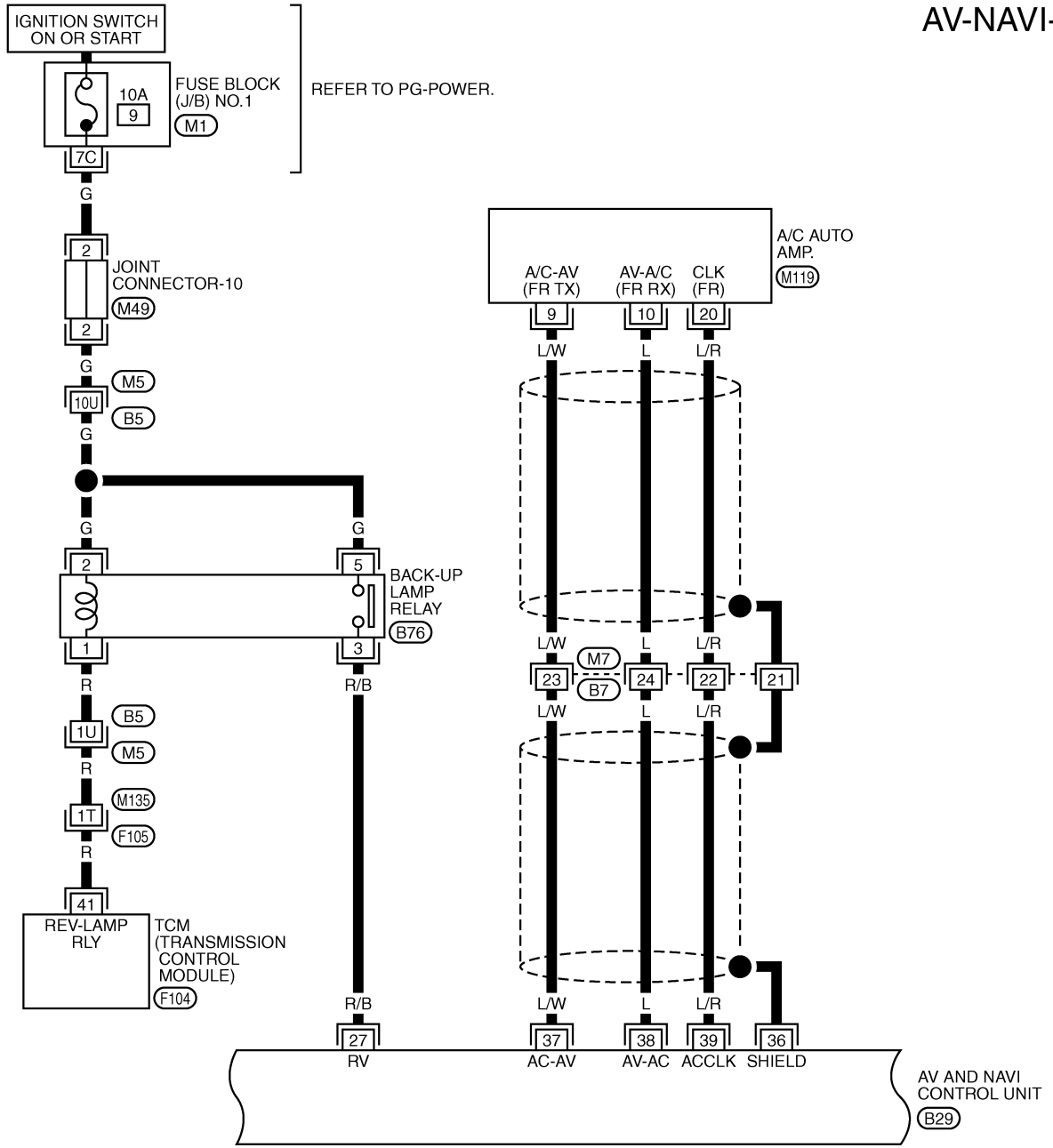

REFER TO THE FOLLOWING.
 (M5), (F105) -SUPER MULTIPLE JUNCTION (SMJ)
 (M1) -FUSE BLOCK-JUNCTION BOX (J/B) NO.1
 (F104) -ELECTRICAL UNITS

TKWA0662E

NAVIGATION SYSTEM

AV-NAVI-04

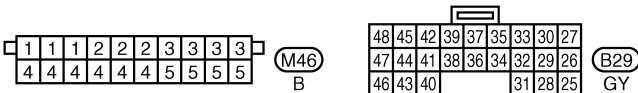
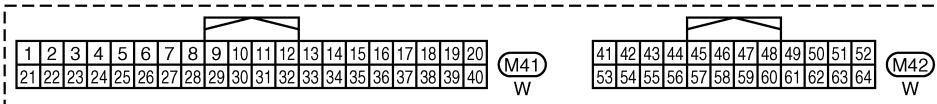
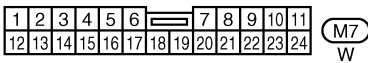
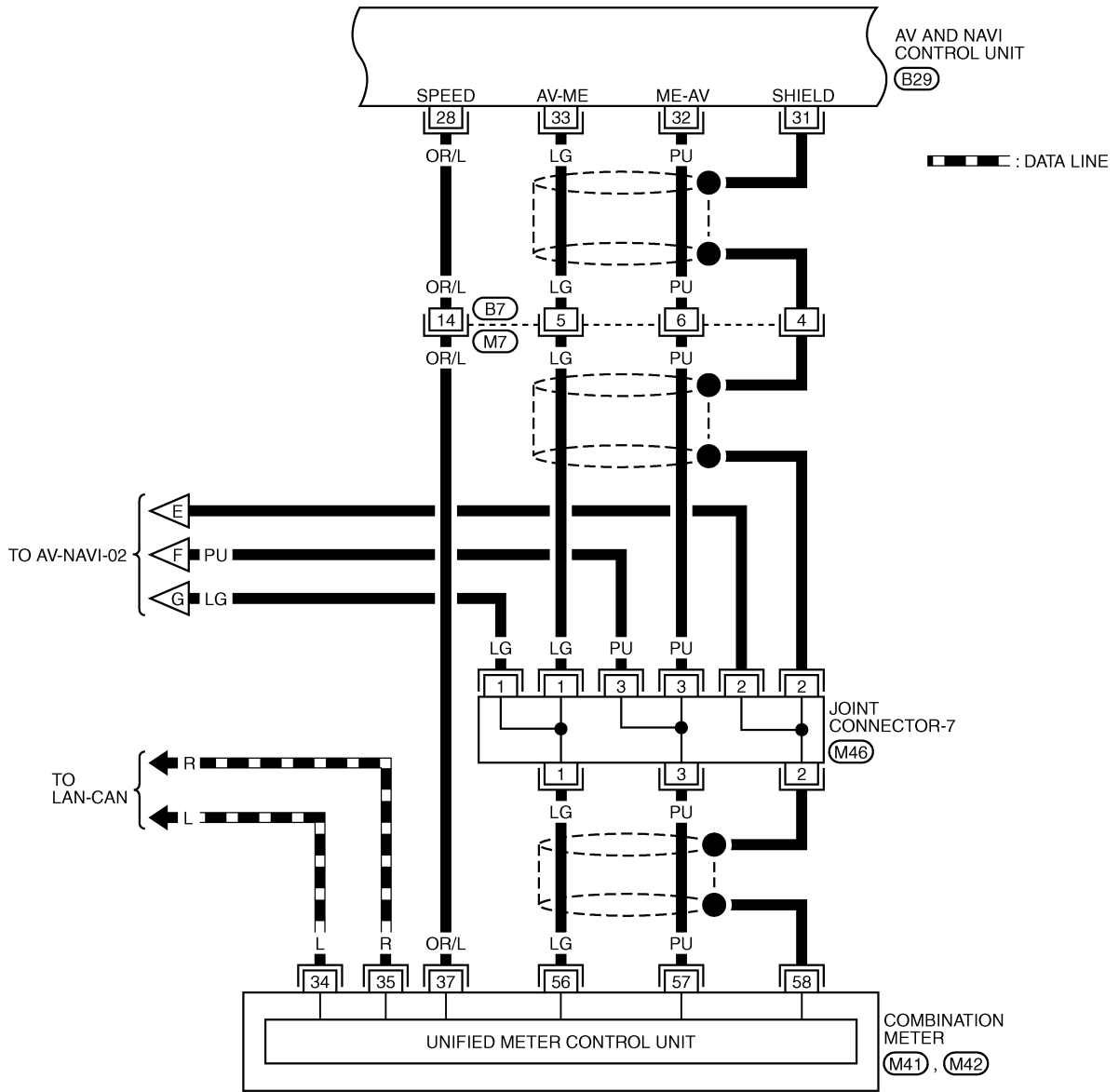

TKWA0663E

NAVIGATION SYSTEM

AV-NAVI-05

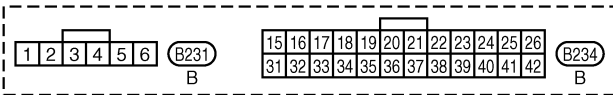
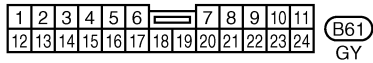
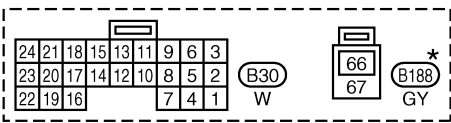
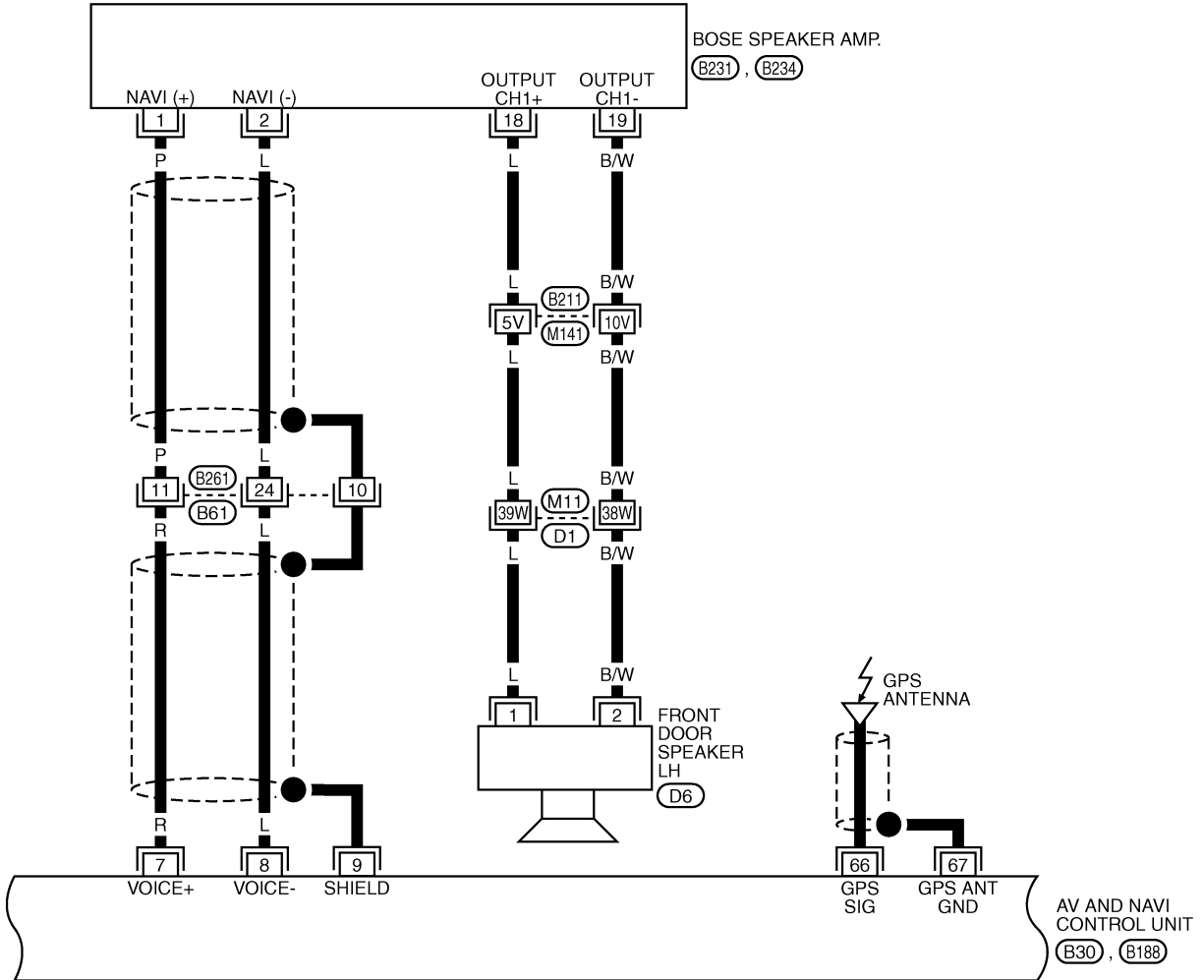

*: THIS CONNECTOR IS NOT SHOWN IN "HARNESS LAYOUT", PG SECTION.

REFER TO THE FOLLOWING.
B211, **D1** -SUPER MULTIPLE JUNCTION (SMJ)

TKWA0664E

NAVIGATION SYSTEM

AV-NAVI-06

A
B
C
D
E
F
G
H
I
J
K
L
M

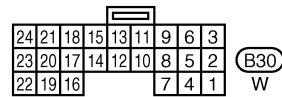
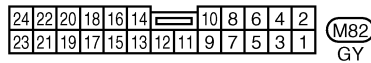
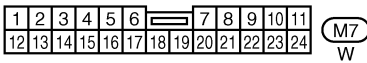
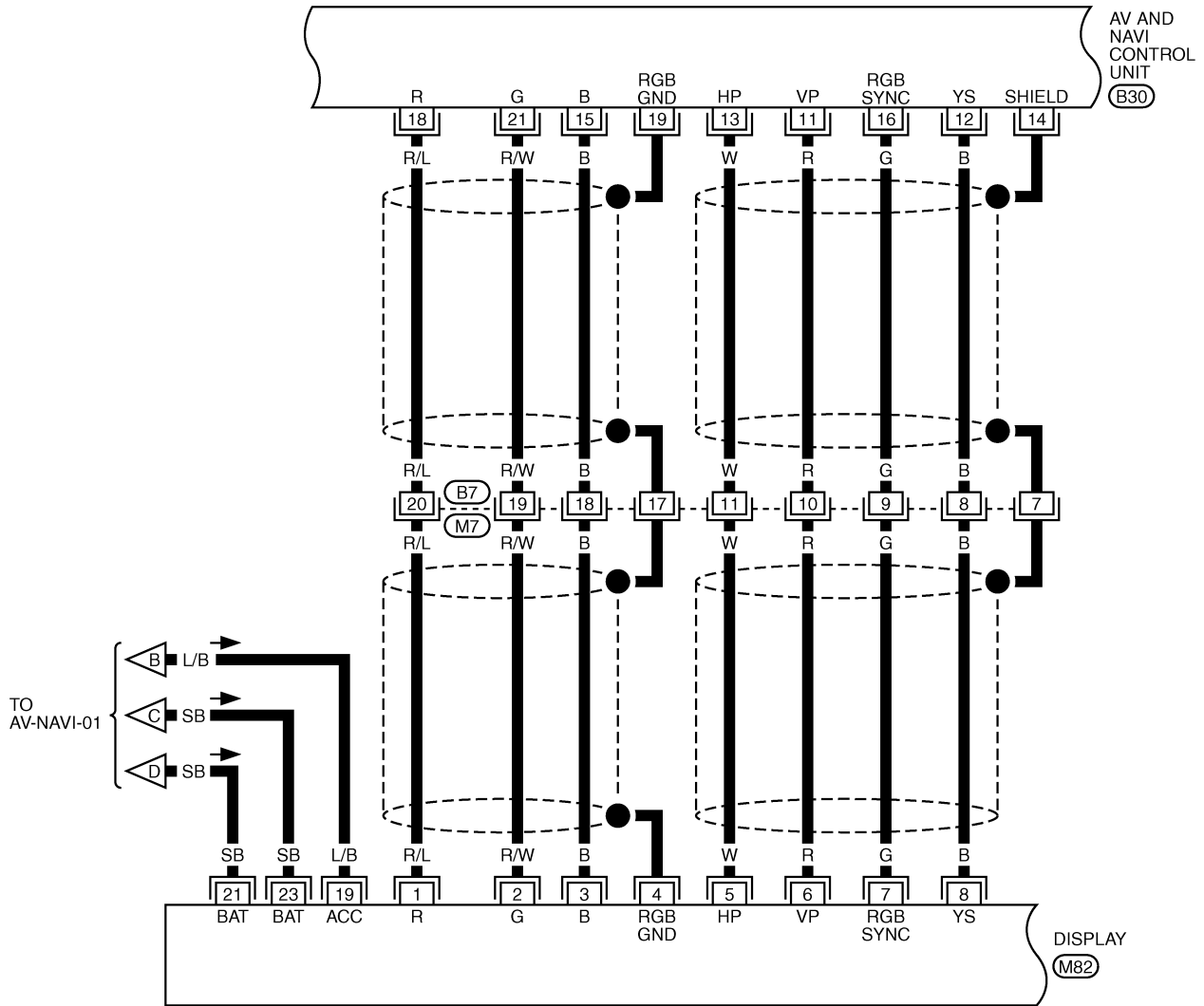

TKWA0665E

NAVIGATION SYSTEM

AV-NAVI-07

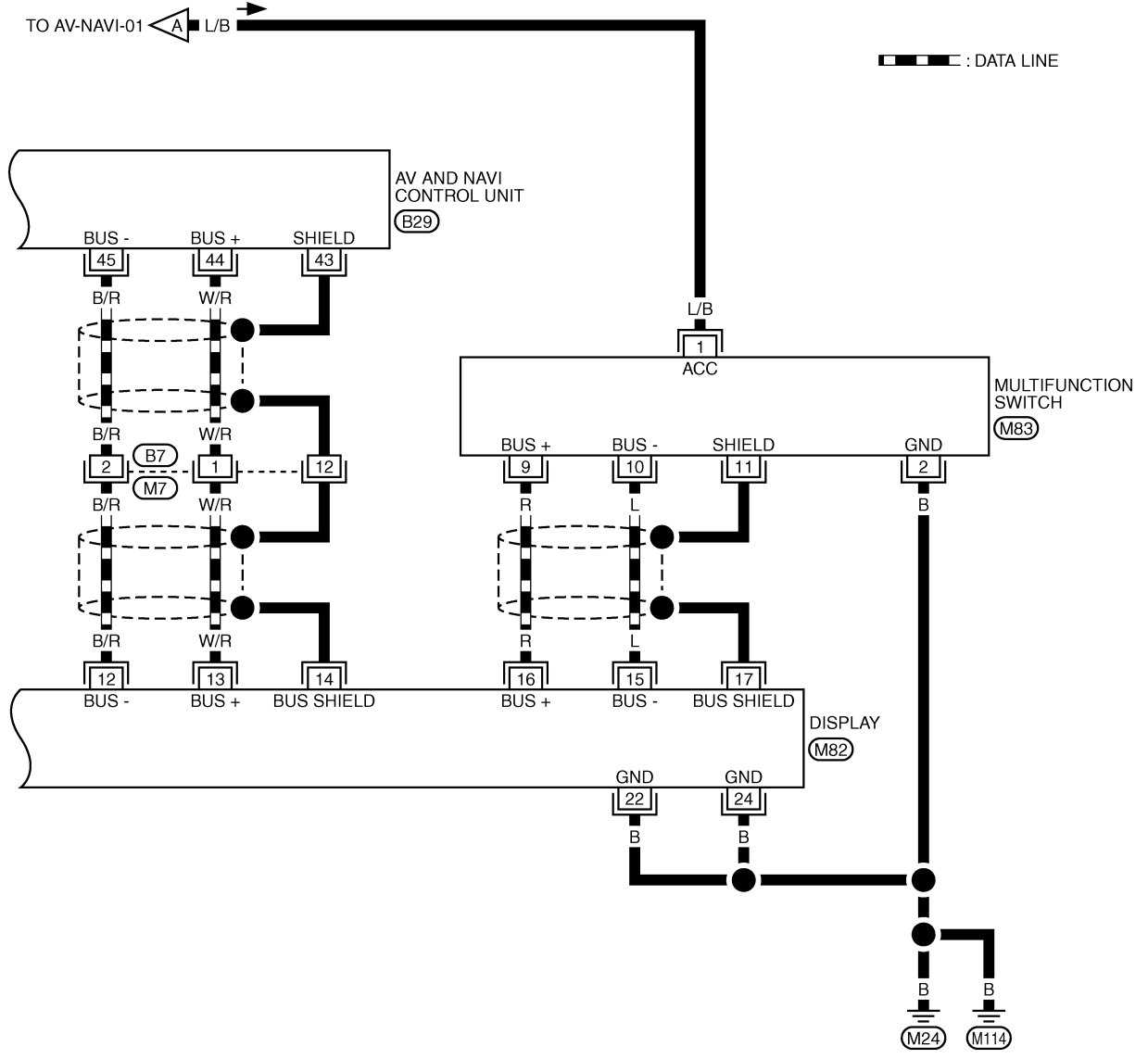

1	2	3	4	5	6	7	8	9	10	11		
12	13	14	15	16	17	18	19	20	21	22	23	24

(M7)
W

24	22	20	18	16	14	10	8	6	4	2		
23	21	19	17	15	13	12	11	9	7	5	3	1

(M82)
GY

20	18	16	14	12	8	6	4	2		
19	17	15	13	11	10	9	7	5	3	1

(M83)
W

48	45	42	39	37	35	33	30	27
47	44	41	38	36	34	32	29	26
46	43	40			31	28	25	

(B29)
GY

TKWA0666E

NAVIGATION SYSTEM

Schematic

AKS003XG

A
B
C
D
E
F
G
H
I
J
L
M

AV

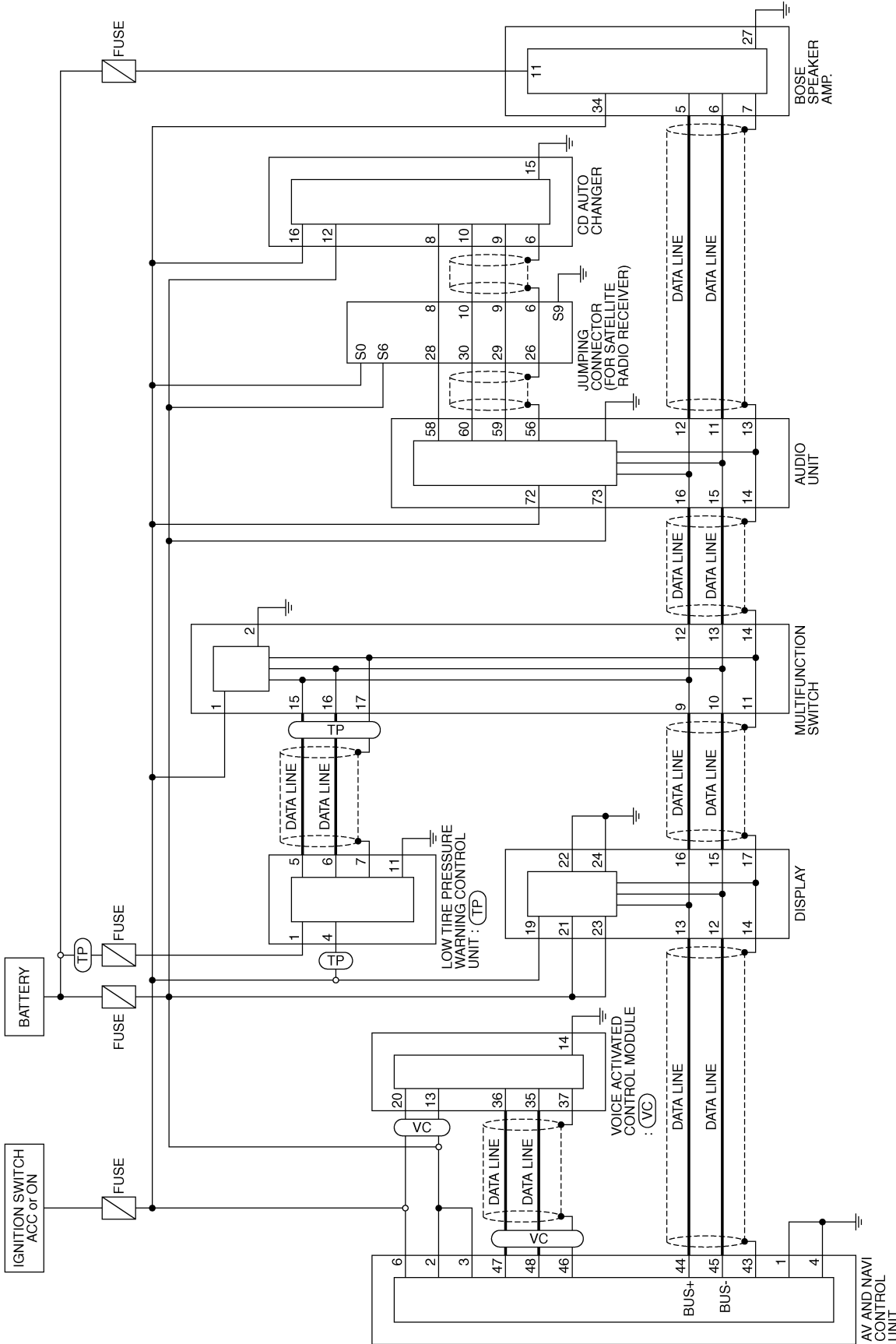

(TP) : With low tire pressure warning system
(VC) : With voice activated control system

TKWA1247E

NAVIGATION SYSTEM

Wiring Diagram — COMM —

AKS003XH

AV-COMM-01

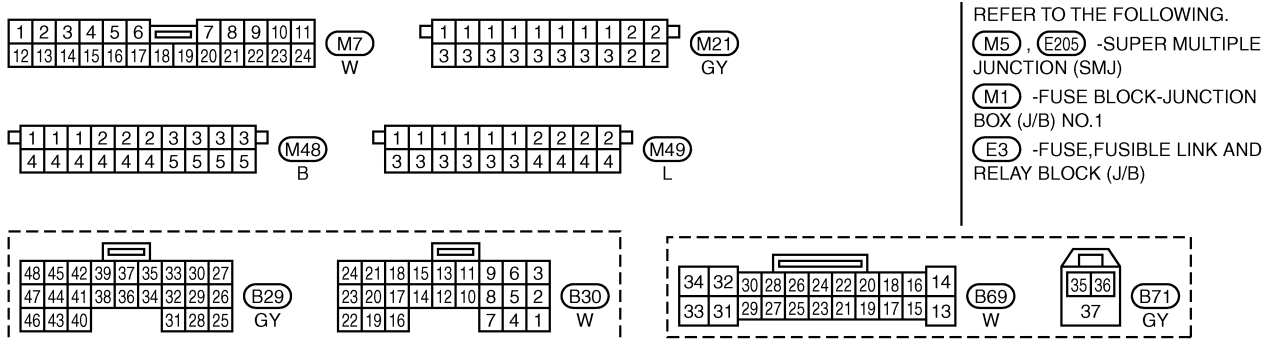
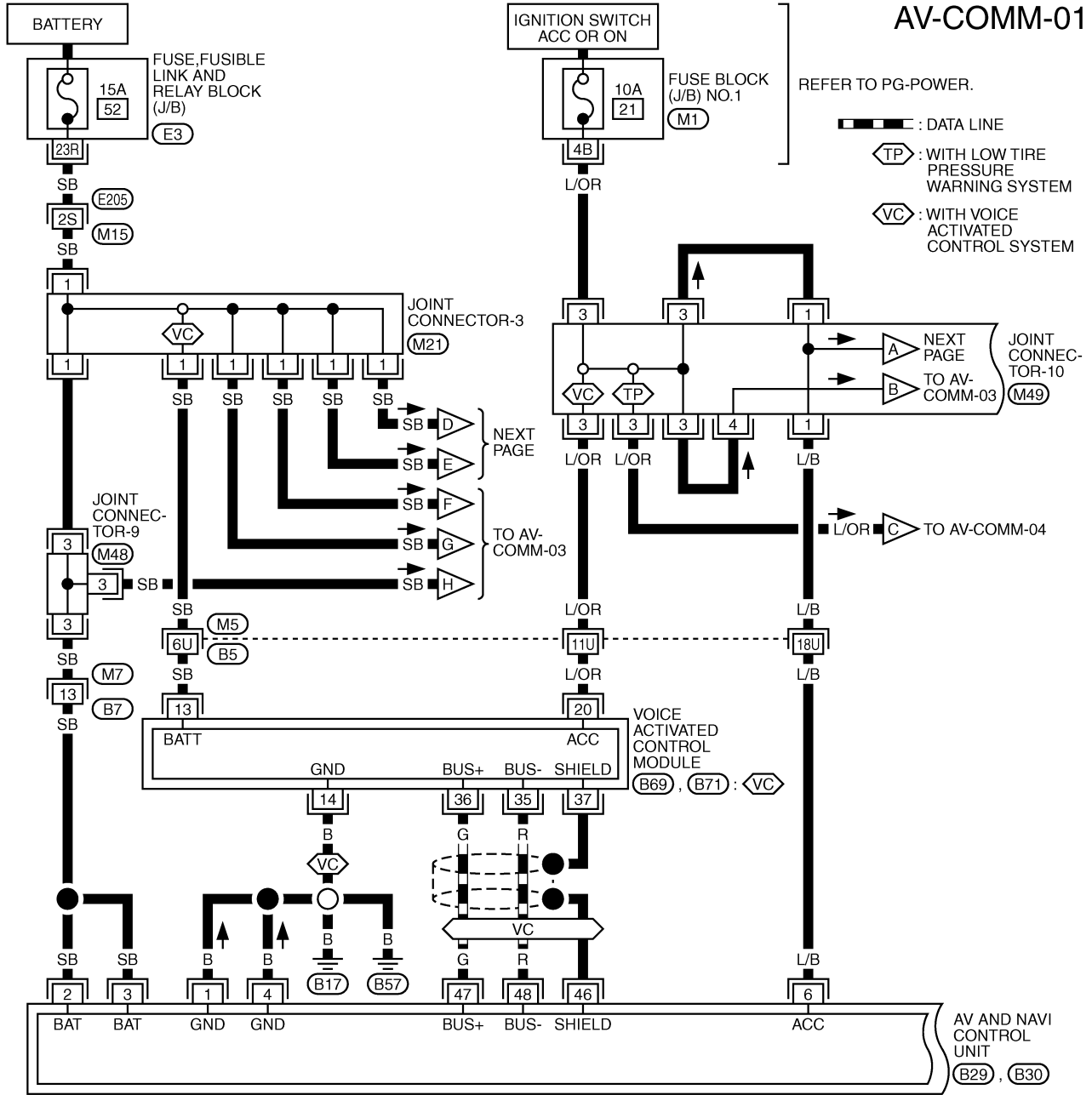

NAVIGATION SYSTEM

AV-COMM-02

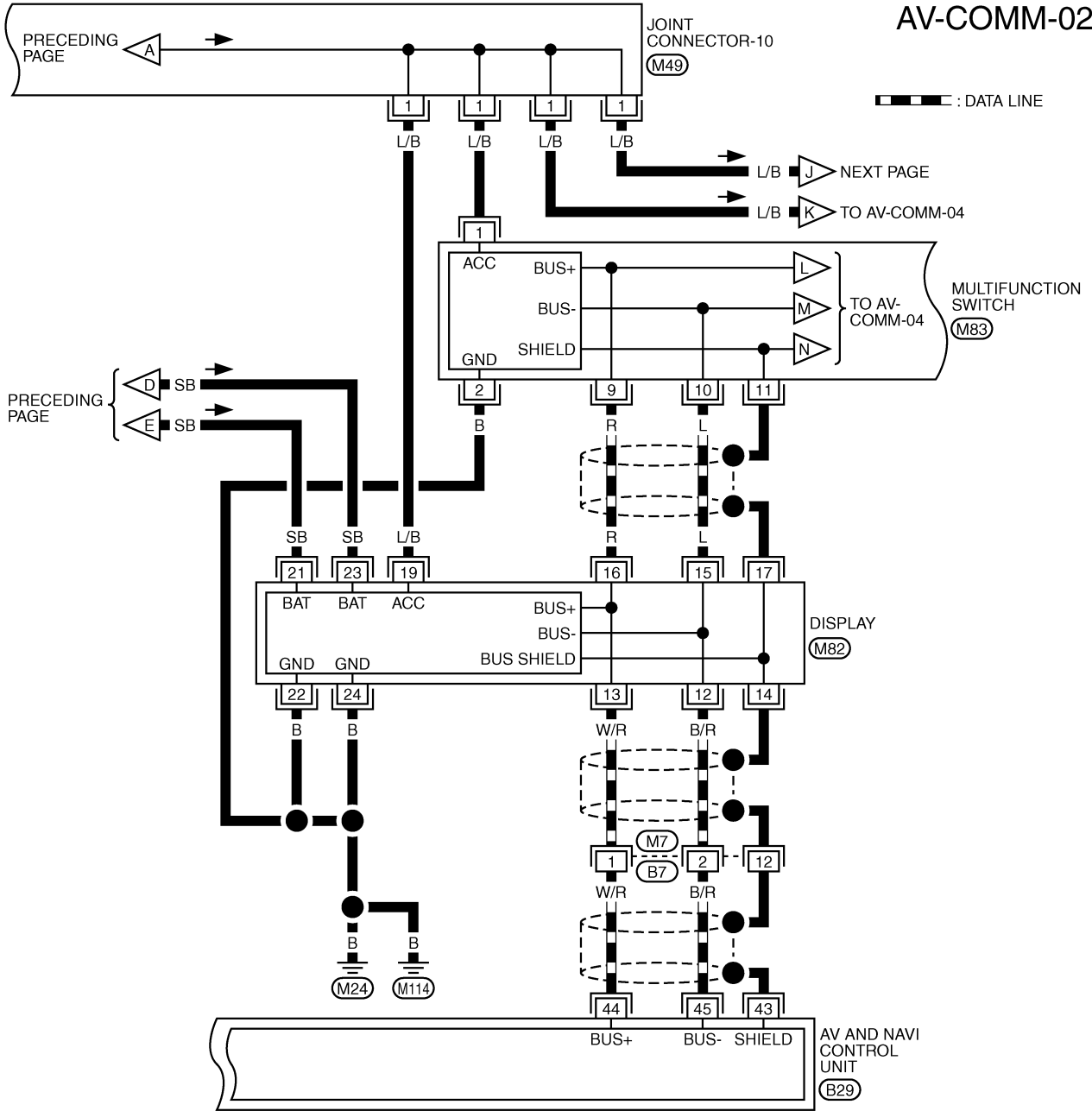

1	2	3	4	5	6	7	8	9	10	11		
12	13	14	15	16	17	18	19	20	21	22	23	24

(M7) W

1	1	1	1	1	1	2	2	2	2
3	3	3	3	3	4	4	4	4	4

(M49) L

24	22	20	18	16	14	10	8	6	4	2		
23	21	19	17	15	13	12	11	9	7	5	3	1

(M82) GY

20	18	16	14	12	8	6	4	2		
19	17	15	13	11	10	9	7	5	3	1

(M83) W

48	45	42	39	37	35	33	30	27
47	44	41	38	36	34	32	29	26
46	43	40				31	28	25

(B29) GY

A
B
C
D
E
F
G
H
I
J
AV
L
M

TKWA1249E

NAVIGATION SYSTEM

AV-COMM-03

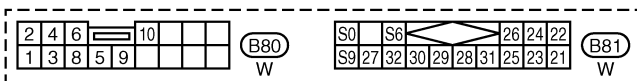
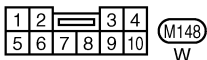
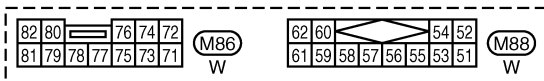
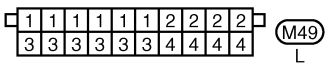
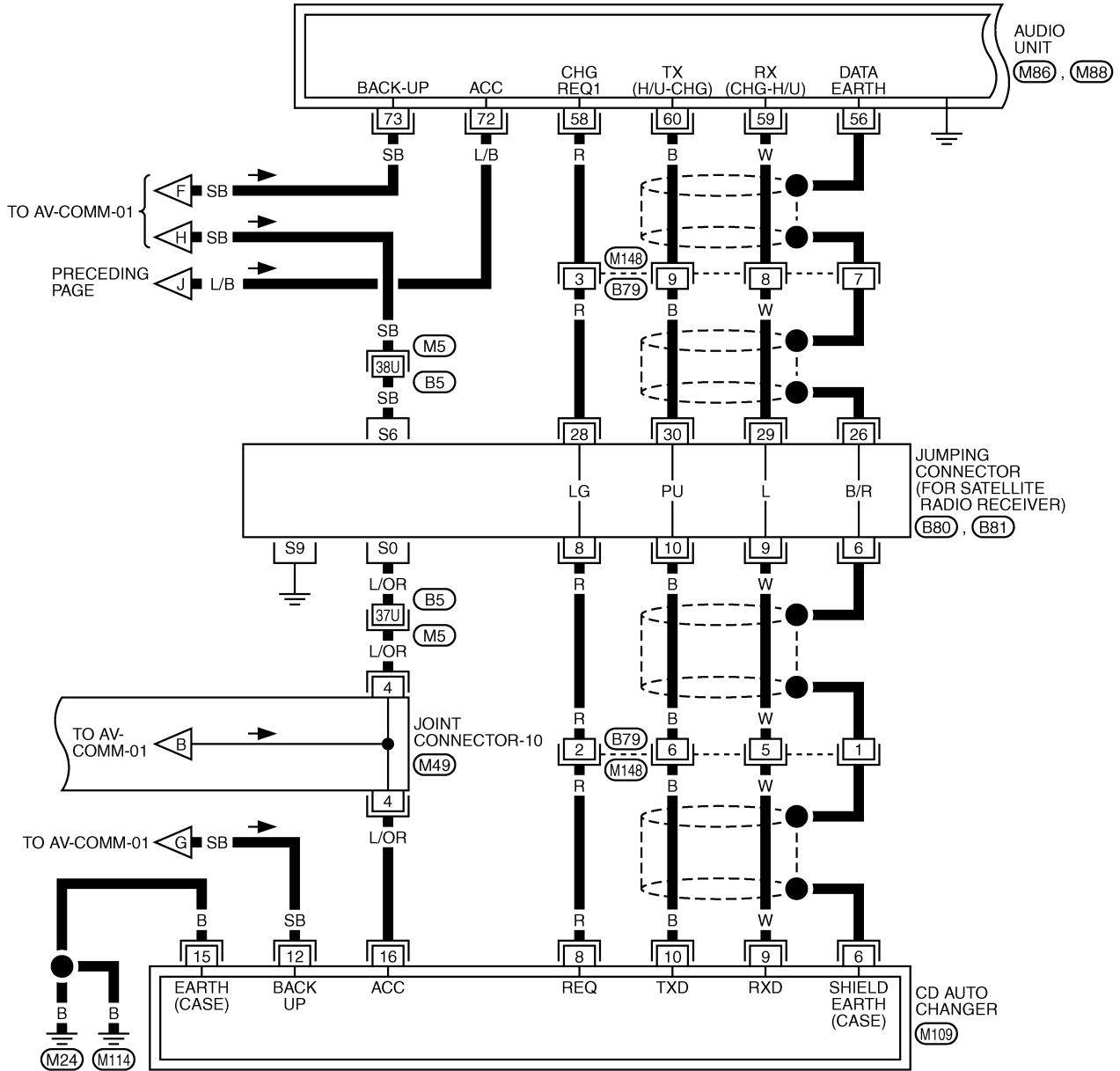

REFER TO THE FOLLOWING.

(M5) -SUPER MULTIPLE JUNCTION (SMJ)

NAVIGATION SYSTEM

AV-COMM-04

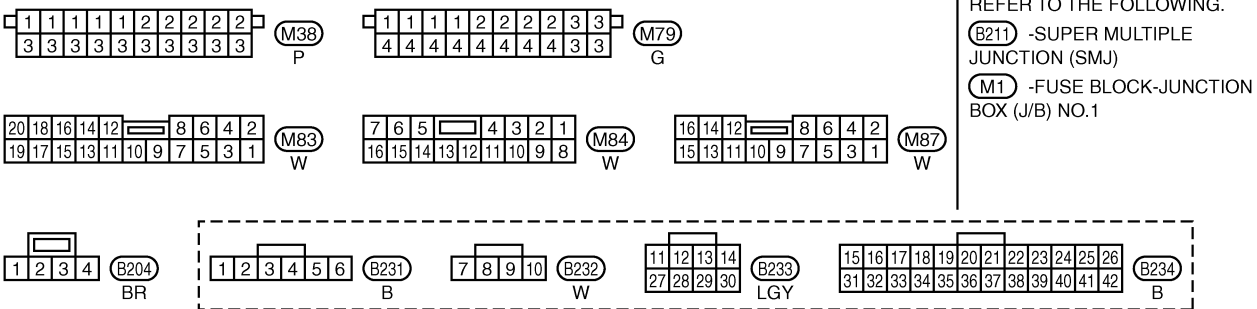
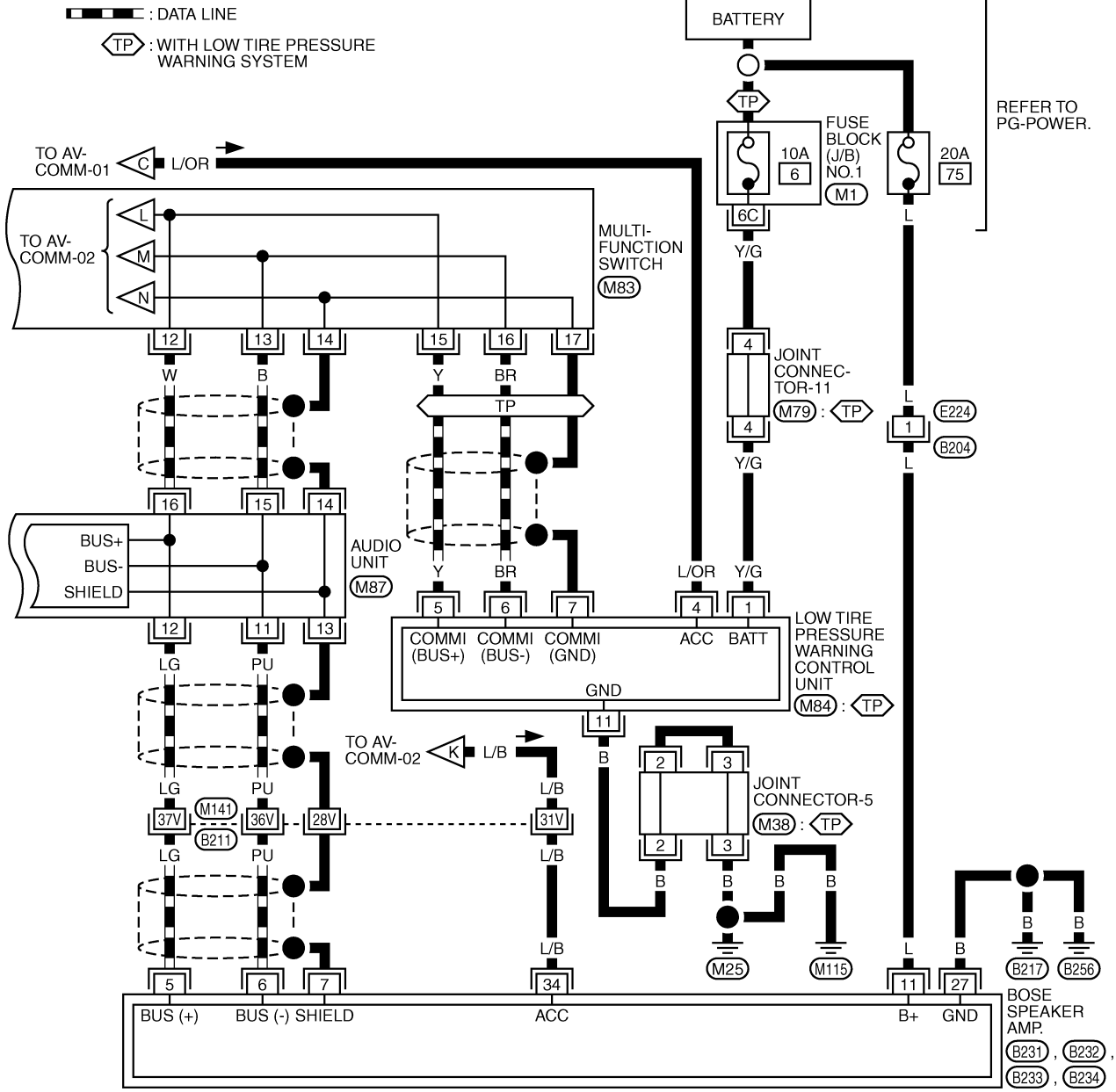

TKWA1251E

NAVIGATION SYSTEM

Terminals and Reference Value for AV and NAVI Control Unit

AKS003X1

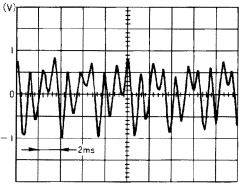
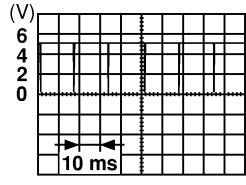
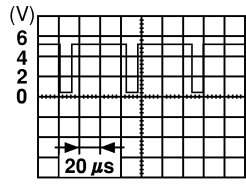
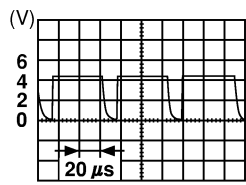
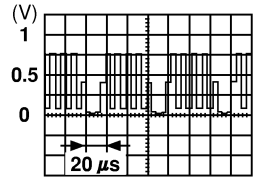
Terminal No. (Wire color)		Item	Signal input/ output	Condition		Voltage	Example of symptom
+	-			Ignition switch	Operation		
1 (B)	Ground	Ground	-	ON	-	Approx. 0 V	-
2 (SB)	Ground	Battery power	Input	OFF	-	Battery voltage	System does not work properly.
3 (SB)							
4 (B)	Ground	Ground	-	ON	-	Approx. 0 V	-
6 (L/B)	Ground	ACC signal	Input	ACC	-	Battery voltage	System does not work properly.
7 (R)	8 (L)	Voice guide signal	Output	ON	Press the "voice" switch.		Only route guide and operation guide are not heard.
<small>SKIA0171J</small>							
9	-	Shield ground	-	-	-	-	-
11 (R)	14	Vertical syn- chronizing signal	Input	ON	-		Superimposed screen is rolling.
<small>SKIA0161E</small>							
12 (B)	14	RGB area signal	Output	ON	Press the "info" switch.		RGB screen is not shown.
<small>SKIA0162E</small>							
13 (W)	14	Horizontal synchroniz- ing signal	Input	ON	Select "Rearview" in "Confirmation/ Adjustment Mode" mode and display the rearview picture on the screen.		RGB screen is not shown.
<small>SKIA0163E</small>							
14	Ground	Shield Ground	-	ON	-	Approx. 0 V	-
15 (B)	19	RGB signal (B: blue)	Output	ON	Select "SCREEN ADJUSTMENT" of Confirmation/ Adjustment Mode function.		RGB screen looks yellowish.
<small>SKIA0167E</small>							

NAVIGATION SYSTEM

Terminal No. (Wire color)		Item	Signal input/ output	Condition		Voltage	Example of symptom								
+	-			Ignition switch	Operation										
16 (G)	14	RGB syn- chronizing signal	Output	ON	Press the "MAP" switch.	<p style="text-align: right; font-size: small;">SKIA0164E</p>	RGB screen is rolling.								
18 (R/L)	19	RGB signal (R: red)	Output	ON	Select "SCREEN ADJUSTMENT" of Confirmation/ Adjustment Mode function.	<p style="text-align: right; font-size: small;">SKIA0165E</p>	RGB screen looks bluish.								
19	-	RGB ground	-	-	-	-	-								
21 (R/W)	19	RGB signal (G: green)	Output	ON	Select "SCREEN ADJUSTMENT" of Confirmation/ Adjustment Mode function.	<p style="text-align: right; font-size: small;">SKIA0166E</p>	RGB screen looks reddish.								
25 (R/L)	Ground	Illumination control signal	Input	ON	<table border="0" style="width: 100%;"> <tr> <td style="width: 50%; vertical-align: top;">Lighting switch ON (posi- tion 1)</td> <td style="width: 50%; vertical-align: top;">Optical sensor is exposed to light.</td> </tr> <tr> <td style="width: 50%; vertical-align: top;">Optical sensor is not exposed to light.</td> <td style="width: 50%;"></td> </tr> </table>	Lighting switch ON (posi- tion 1)	Optical sensor is exposed to light.	Optical sensor is not exposed to light.		<table border="0" style="width: 100%;"> <tr> <td style="width: 50%; text-align: center;">Approx. 12V</td> <td style="width: 50%;"></td> </tr> <tr> <td style="width: 50%; text-align: center;">Approx. 0V</td> <td style="width: 50%;"></td> </tr> </table>	Approx. 12V		Approx. 0V		Screen does not switch between daytime mode and nighttime mode.
Lighting switch ON (posi- tion 1)	Optical sensor is exposed to light.														
Optical sensor is not exposed to light.															
Approx. 12V															
Approx. 0V															
26 (W/G)	Ground	Ignition signal	Input	ON	-	Battery voltage	A/C operation is not possible. Vehicle informa- tion setting is not possible.								
27 (R/B)	Ground	Reverse sig- nal	Input	ON	<table border="0" style="width: 100%;"> <tr> <td style="width: 50%;">AT selector lever in R-position</td> <td style="width: 50%;">Battery voltage</td> </tr> <tr> <td style="width: 50%;">AT selector lever not in R-position</td> <td style="width: 50%;">Approx. 0V</td> </tr> </table>	AT selector lever in R-position	Battery voltage	AT selector lever not in R-position	Approx. 0V	The navigation current-location mark moves strangely when the vehicle is moving back- wards.					
AT selector lever in R-position	Battery voltage														
AT selector lever not in R-position	Approx. 0V														
28 (OR/L)	Ground	Vehicle speed signal (8-pulse)	Input	ON	When vehicle speed is approx. 40 km/h (25 MPH)	<p style="text-align: right; font-size: small;">SKIA0168E</p>	Navigation cur- rent-location mark does not indicate the cor- rect position.								
30 (B)	Ground	Illumination ground	-	ON	-	Approx. 0V	-								

A
B
C
D
E
F
G
H
I
J
AV
L
M

NAVIGATION SYSTEM

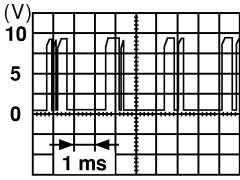
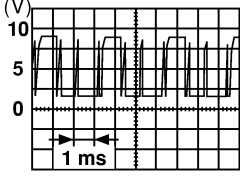
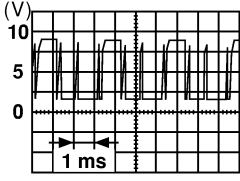
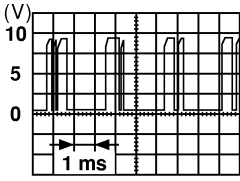
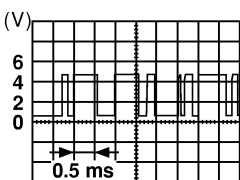
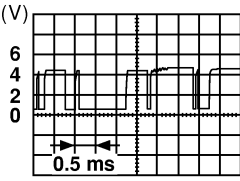
Terminal No. (Wire color)		Item	Signal input/ output	Condition		Voltage	Example of symptom
+	-			Ignition switch	Operation		
31	-	Shield ground	-	-	-	-	-
32 (PU)	Ground	Communica- tion signal (ME-AV)	Input	ON	Perform various set- tings on the vehicle information screen.	 SKIA0170E	Clock cannot be adjusted. Vehicle informa- tion screen is not shown.
33 (LG)	Ground	Communica- tion signal (AV-ME)	Output	ON	Display the vehicle information screen.	 SKIA0169E	Clock cannot be adjusted. Vehicle informa- tion screen is not shown.
34 (P)	Ground	CONSULT-II communica- tion signal (AV-CN)	Output	ON	Perform CONSULT- II.	 SKIA0169E	Diagnosis with CONSULT-II is not possible.
35 (BR/Y)	Ground	CONSULT-II communica- tion signal (CN-AV)	Input	ON	Perform CONSULT- II.	 SKIA0170E	Diagnosis with CONSULT-II is not possible.
36	-	Shield ground	-	-	-	-	-
37 (L/W)	Ground	A/C commu- nication signal (AC-AV)	Input	ON	-	 SKIA0173E	A/C status is not indicated cor- rectly.
38 (L)	Ground	A/C commu- nication signal (AV-AC)	Output	ON	-	 SKIA0172E	A/C operation is not possible.

NAVIGATION SYSTEM

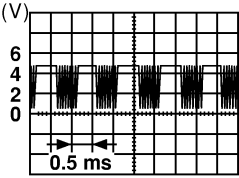
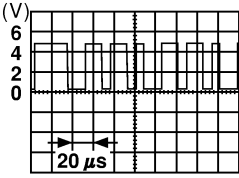
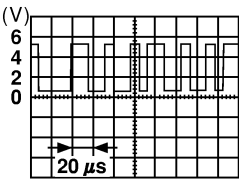
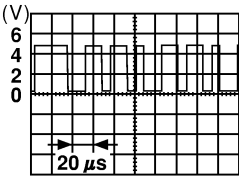
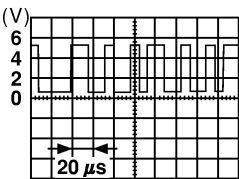
Terminal No. (Wire color)		Item	Signal input/ output	Condition		Voltage	Example of symptom
+	-			Ignition switch	Operation		
39 (L/R)	Ground	A/C clock signal	Input	ON	-	 <p style="text-align: right; font-size: small;">SKIA0174E</p>	A/C status is not indicated correctly.
43	-	Shield ground	-	-	-	-	-
44 (W/R)	Ground	Communication signal (+)	Input/output	ON	-	 <p style="text-align: right; font-size: small;">SKIA0175E</p>	System does not work properly.
45 (B/R)	Ground	Communication signal (-)	Input/output	ON	-	 <p style="text-align: right; font-size: small;">SKIA0176E</p>	System does not work properly.
46	-	Shield	-	-	-	-	-
47 (G)	Ground	Communication signal (+)	Input/output	ON	-	 <p style="text-align: right; font-size: small;">SKIA0175E</p>	System does not work properly.
48 (R)	Ground	Communication signal (-)	Input/output	ON	-	 <p style="text-align: right; font-size: small;">SKIA0176E</p>	System does not work properly.
66	67	GPS signal	Input	ON	Connector is not connected.	Approx. 5 V	Navigation system GPS correction is not possible.

A
B
C
D
E
F
G
H
I
J
L
M

AV

NAVIGATION SYSTEM

On Board Self-Diagnosis Function (Without CONSULT-II)

AKS003XJ

DESCRIPTION

- Diagnosis function consists of the self-diagnosis mode performed automatically and the Confirmation/Adjustment Mode mode operated manually.
- Self-diagnosis mode checks for connections between the units constituting this system, analyzes each individual unit at the same time, and displays the results on the LCD screen.
- Confirmation/Adjustment Mode mode is used to perform trouble diagnosis that require operation and judgment by an operator (malfunction that cannot be automatically judged by the system), to check/change the set value, and to display the History of Errors of the navigation system.

DIAGNOSIS ITEM

Mode		Description	
Self-diagnosis		<ul style="list-style-type: none"> ● AV and NAVI control unit diagnosis (DVD-ROM drive will not be diagnosed when no map DVD-ROM is in it.). ● Analyzes connection between the AV and NAVI control unit and the GPS antenna connection between the AV and NAVI control unit and each unit, and operation of each unit. 	
Confirmation/ Adjustment Mode	Display diagnosis	Color tone and shading of the screen can be checked by the display of a color bar and a gray scale.	
	Vehicle signals	Analyzes the following vehicle signals: Vehicle speed signal, parking brake signal, light signal, ignition switch signal, and reverse signal.	
	Auto Climate Control	Turns all A/C screens on display and A/C switch indicator lamp on.	
	Navigation	Display Longitude & Latitude	Display the map. Use the joystick to adjust position. Longitude and latitude will be displayed.
		Speed Calibration	Under ordinary conditions, the navigation system distance measuring function will automatically compensate for minute decreases in wheel and tire diameter caused by tire wear or low pressure. Speed calibration immediately restores system accuracy in cases such as when distance calibration is needed because of the use of tire chains in inclement weather.
		Angle adjustment	Corrects difference between actual turning angle of a vehicle and turning angle of the car mark on the display.
		Initialize Location	This mode is for initializing the current location. Use when the vehicle is transported a long distance on a trailer, etc.
History of Errors	Diagnosis results previously stored in the memory (before turning ignition switch ON) are displayed in this mode. Time and location when/where the errors occurred are also displayed.		

NAVIGATION SYSTEM

Self-Diagnosis Mode OPERATION PROCEDURE

AKS003XX

1. Start the engine.
2. Turn the audio system off.
3. While pressing the "INFO" switch, turn the volume control dial clockwise or counterclockwise for 30 clicks or more. (When the self diagnosis mode is started, a short beep will be heard.)
 - Shifting from current screen to previous screen is performed by pressing "PREV" switch.

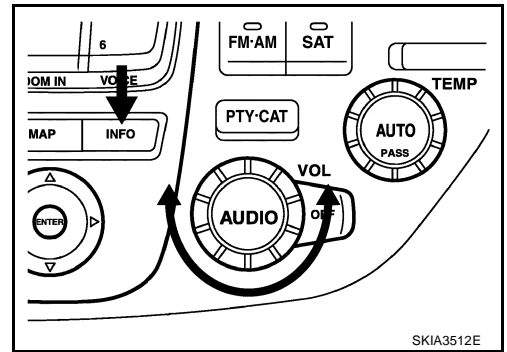

4. The initial trouble diagnosis screen will be shown, and items "Self Diagnosis" and "Confirmation/Adjustment" will become selective.

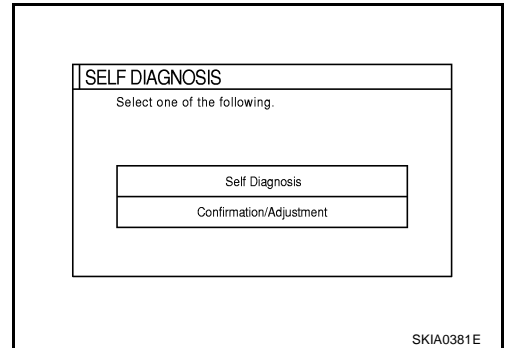

5. Perform self-diagnosis by selecting the "Self Diagnosis".
 - Self-diagnosis subdivision screen will be shown and the operation enters the self-diagnosis mode.
 - A bar graph shown below the self-diagnosis subdivision screen indicates progress of the diagnosis.

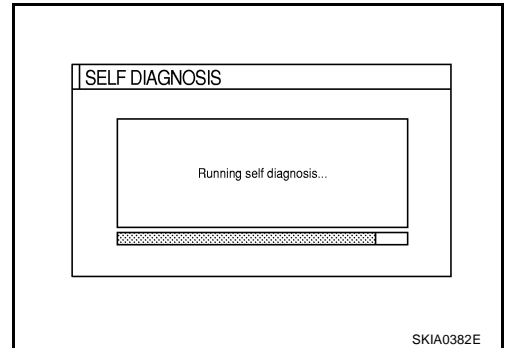

6. When the self-diagnosis completes, optional part confirmation screen will be shown.
 - When connection of an optional part is judged error, a screen to check if the optional part is actually fitted on the vehicle or not will be shown. When fitted, select the switch of the part on the screen and press "END". Then the "SELF DIAGNOSIS" screen will be shown.
 - When the optional part is connected normally, the switch for the part will not appear on the screen.

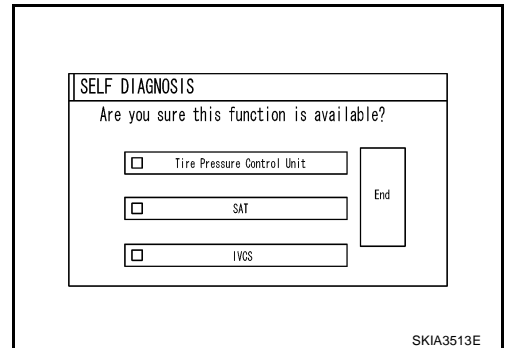

A
B
C
D
E
F
G
H
I
J
AV
L
M

NAVIGATION SYSTEM

7. On the “SELF DIAGNOSIS” screen, each unit name will be colored according to the diagnosis result, as follows.

Green : No malfunctioning.

Yellow : Cannot be judged by self-diagnosis results.

Red : Unit is malfunctioning.

Gray : Diagnosis has not been done.

- If several malfunctions are present in a unit, color of its switch on the screen will be either red, yellow, or gray, determined by the malfunction of the highest priority.

CAUTION:

“Tire Pressure Control Unit” on the screen will be illuminated in yellow when performing self-diagnosis with ignition switch in ACC position.

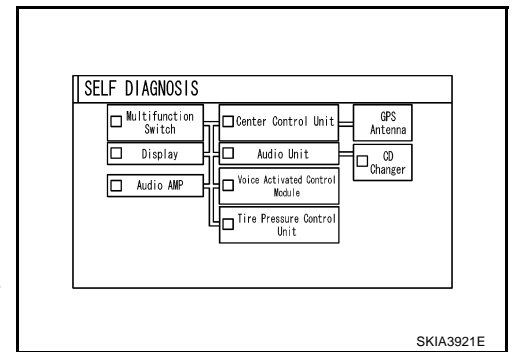

8. Select a switch on the “SELF DIAGNOSIS” screen and comments for the diagnosis results will be shown.

- When the switch is green, the following comment will be shown. “Self-diagnosis was successful. Further diagnosis and adjustments are recommended. Follow the “confirmation and adjustments” menu or refer to the service manual.”.

- When the switch is yellow, the following comment will be shown. “Connection to the following unit is abnormal. See the service manual for further details”.

- When the switch is red, the following comment will be shown. “Center Control Unit is abnormal”.

- When the switch is gray, the following comment will be shown. “Self-diagnosis for DVD-ROM DRIVER of NAVI was not conducted because no DVD-ROM was available.”.

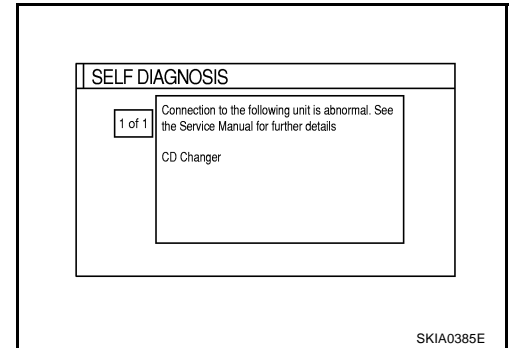

NAVIGATION SYSTEM

SELF-DIAGNOSIS RESULT

Quick Reference Table

1. Select an applicable diagnosis No. in the diagnosis result quick reference table.
2. Find estimated malfunctioning system in the diagnosis No. table and perform check by referring to [AV-60. "Wiring Diagram — COMM —"](#).
3. Turn ignition switch OFF and perform self-diagnosis again.

Screen switch									Diagnosis No.
Switch color	Center control unit*	Display	Tire pressure control unit	Audio unit	CD auto changer	Audio amp.	Voice activated control module	GPS antenna	
Red	×								1
Gray	×								2
Yellow	×	×							3
	×		×						4
	×			×	×				5
						×			6
	×						×		7
	×							×	8
	×								9
	×						×		10
	×						×		11
	×				×	×	×		12

*: Center Control unit = AV and NAVI control unit

CAUTION:

- When multifunction switch has an incident, you can not start.
- Check the following when the self-diagnosis mode can not be used.
 - AV communication line between AV and NAVI control unit and Display, AV communication line between Display and multifunction switch.
 - multifunction switch power supply and ground circuit
- When an error is in the AV communication line, it cannot be detected on the screen because self-diagnosis is inoperative. However, the error can be detected with CONSULT-II.

NAVIGATION SYSTEM

Self-Diagnosis Codes

Diagnosis No.	Possible cause
1	AV and NAVI control unit malfunction
2	No map DVD-ROM is inserted in the AV and NAVI control unit.
3	Display power supply and ground circuit
4	Low tire pressure warning control unit power supply and ground circuit, AV communication line between low tire pressure warning control unit and multifunction switch.
5	Audio unit power supply and ground circuit
6	CD auto changer power supply and ground circuit, AV communication line between CD auto changer and audio unit.
7	Audio amplifier power supply and ground circuit.
8	Voice activated control module power supply and ground circuit.
9	GPS antenna system 1. Visually check for a broken wire in the GPS antenna coaxial cable. 2. Disconnect the GPS antenna connector, and make sure approximately 5V is supplied from the AV and NAVI control unit. If not, the AV and NAVI control unit is malfunctioning. If 5V is supplied, replace the GPS antenna. If the connection is still malfunction after the replacement of the GPS antenna, the AV and NAVI control unit is malfunctioning.
10	AV communication line between voice activated control unit and the AV and NAVI control unit.
11	AV communication line between audio amplifier and audio unit. Audio amplifier internal communication circuit.
12	AV communication line between audio unit and multifunction switch. Audio control unit communication circuit.

NAVIGATION SYSTEM

Confirmation/Adjustment Mode OPERATION PROCEDURE

AKS003XL

1. Start the engine.
2. Turn the audio system off.
3. While pressing the "INFO" switch, turn the volume control dial clockwise or counterclockwise for 30 clicks or more. (When the self-diagnosis mode is started, a short beep will be heard.)
 - Shifting from current screen to previous screen is performed by pressing "PREV" switch.

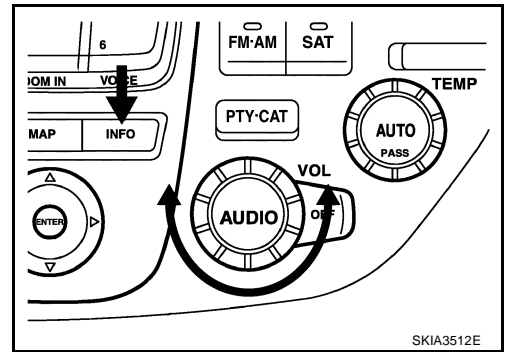

4. The initial trouble diagnosis screen will be shown, and items "Self Diagnosis" and "Confirmation/Adjustment" will become selective.

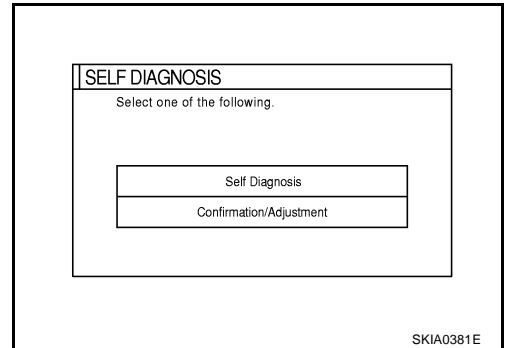

5. When "Confirmation/Adjustment Mode" is selected on the initial trouble diagnosis screen, the operation will enter the Confirmation/Adjustment Mode mode. In this mode, check and adjustment of each item will become possible.
6. Select each switch on "CONFIRMATION/ADJUSTMENT" screen to display the relevant diagnosis screen.

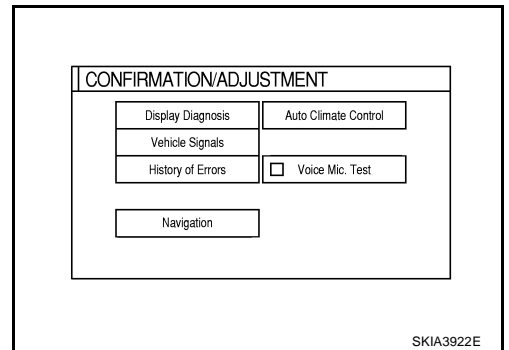

A
B
C
D
E
F
G
H
I
J
AV
L
M

NAVIGATION SYSTEM

DISPLAY DIAGNOSIS

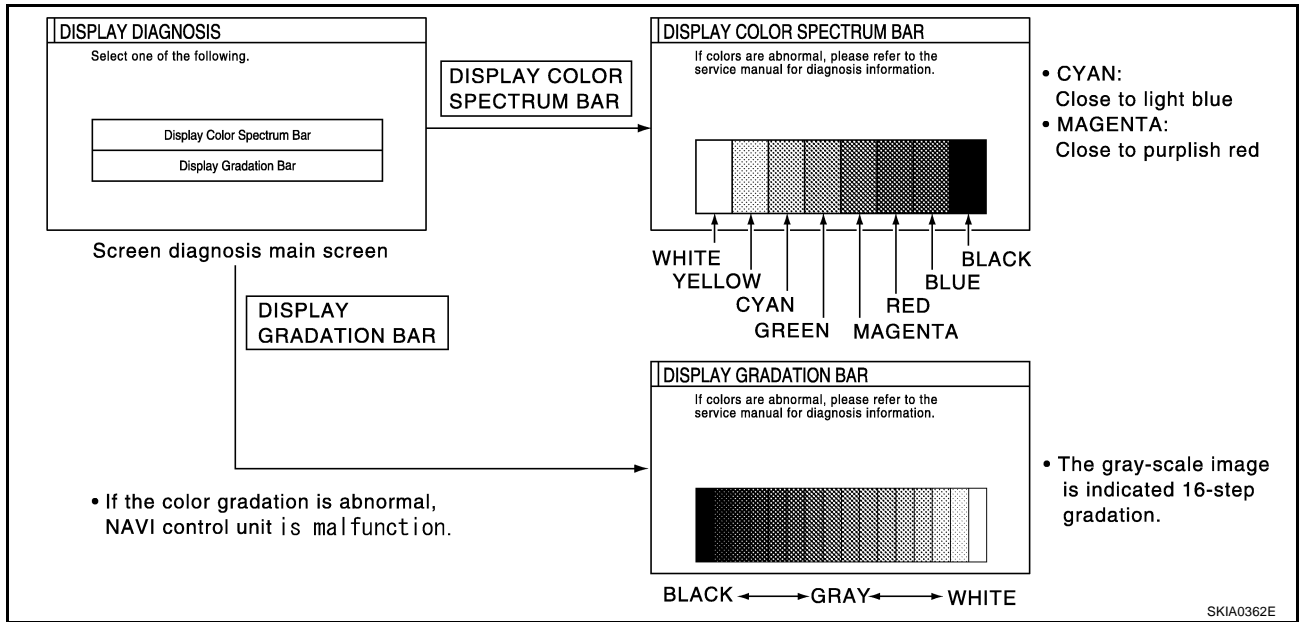

- When RGB signal error occurred in the RGB system, tone of the color bar will change as follows.
 - R (red) signal error** : Screen looks bluish
 - G (green) signal error** : Screen looks yellowish
 - B (blue) signal error** : Screen looks reddish
- When the color of the screen looks unusual, refer to [AV-88, "Color of RGB Image is Not Proper"](#) .

NAVIGATION SYSTEM

VEHICLE SIGNALS

- A comparison check can be made of each actual vehicle signal and the signals recognized by the system.

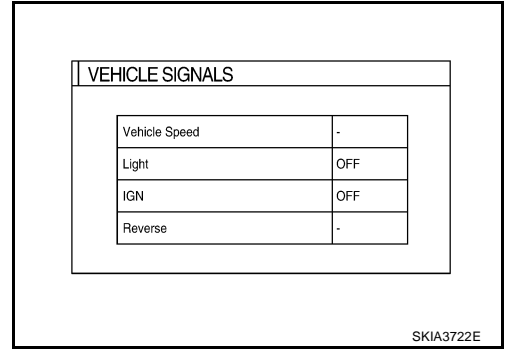

Diagnosis item	Display	Condition	Remarks
Vehicle speed	ON	Vehicle speed > 0 km/h (0 MPH)	Changes in indication may be delayed by approx. 1.5 seconds. This is normal.
	OFF	Vehicle speed = 0 km/h (0 MPH)	
	-	Ignition switch in ACC position	
Light	ON	Lighting switch ON	-
	OFF	Lighting switch OFF	
IGN	ON	Ignition switch ON	-
	OFF	Ignition switch ACC or OFF	
Reverse	ON	Selector lever in R-position	Changes in indication may be delayed by approx. 1.5 seconds. This is normal.
	OFF	Selector lever in other than R-position	
	-	Ignition switch in ACC position	

- If vehicle speed is NG, refer to [AV-84, "Vehicle Speed Signal Check"](#) .
- If light is NG, refer to [AV-84, "Illumination Control Signal Check"](#) .
- If IGN is NG, refer to [AV-85, "Ignition Signal Check"](#) .
- If reverse is NG, refer to [AV-86, "Reverse Signal Check"](#) .

AUTO CLIMATE CONTROL

- Refer to ATC Automatic Air Conditioner [ATC-49, "Self-Diagnosis Function"](#) for details.

NAVIGATION

Angle Adjustment

- Adjusts turning angle output detected by the gyroscope.

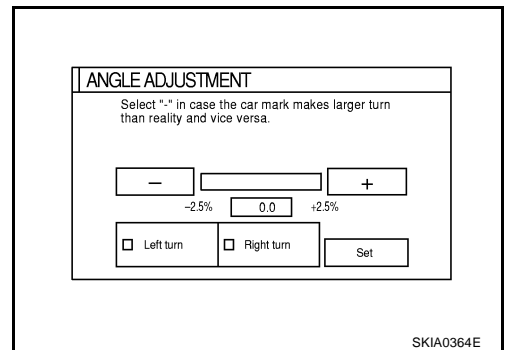

NAVIGATION SYSTEM

Speed Calibration

- During normal driving, distance error caused by tire wear and tire pressure change is automatically adjusted for by the automatic distance correction function. This function, on the other hand, is for immediate adjustment, in cases such as driving with tire chain fitted on tires.

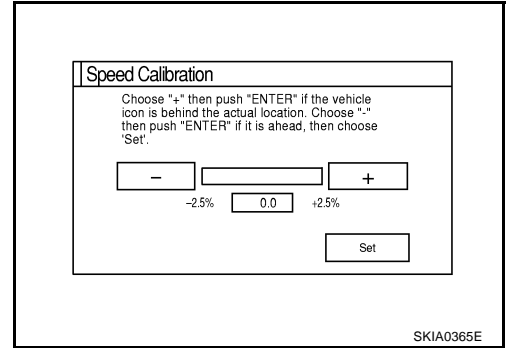

HISTORY OF ERRORS

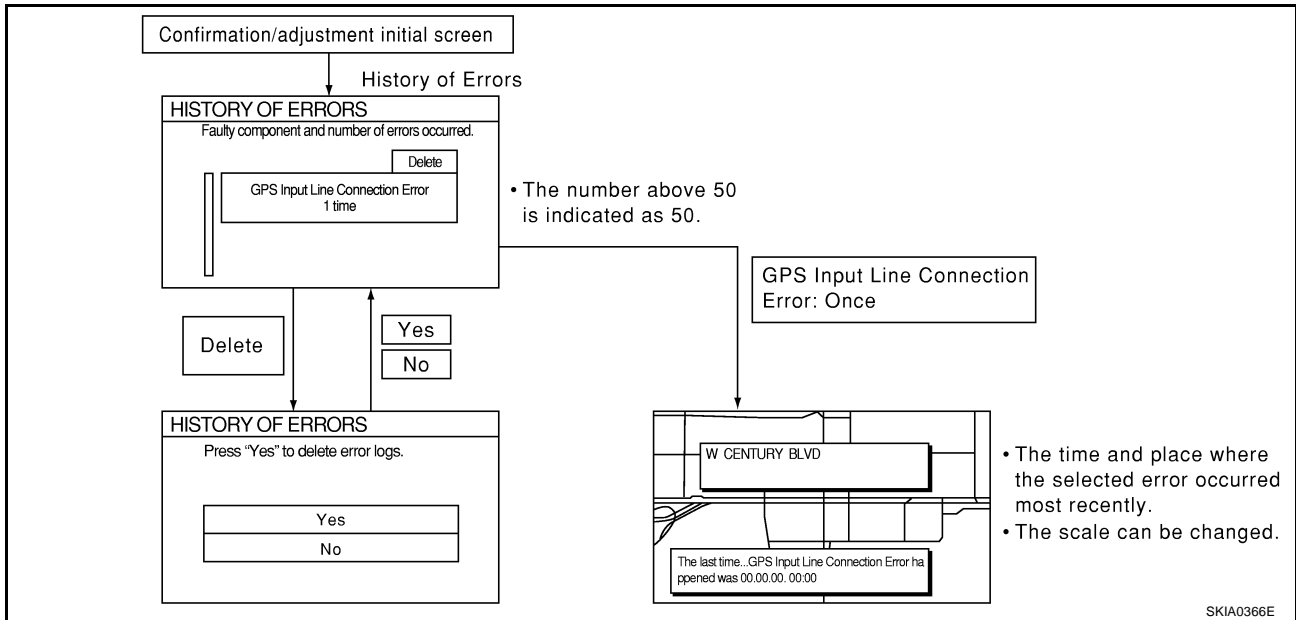

NAVIGATION SYSTEM

DIAGNOSIS BY HISTORY OF ERRORS

The “Self-diagnosis” results indicate whether an error occurred during the period from when the ignition switch is turned to ON until “Self-diagnosis” is completed.

If an error occurred before the ignition switch was turned to ON and does not occur again until the “Self-diagnosis” is completed, the diagnosis result will be judged normal. Therefore, those errors in the past, which cannot be found by the “Self-diagnosis,” must be found by diagnosing the “History of Errors”.

The History of Errors displays the time and place of the most recent occurrence of that error. However, take note of the following points.

- Correct time of the error occurrence may not be displayed when the GPS antenna substrate within the AV and NAVI control unit has malfunctioned.
- Place of the error occurrence is represented by the position of the current-location mark at the time when the error occurred. If the current-location mark has deviated from the correct position, then the place of the error occurrence may be located correctly.
- The maximum number of occurrences which can be stored is 50. For the 51st and later occurrences, the displayed number remains 50.

When a reproducible malfunction occurred but its cause cannot be identified because several errors are present, record the item, number and place (longitude/latitude) of error occurrence (or delete the History of Errors), then turn ignition switch from OFF to ON to reproduce the malfunction. Check the History of Errors to find the items which show an increased number of occurrences, and diagnose the item.

Error item	Possible causes	Example of symptom
	Action/symptom	
Gyro sensor disconnected	Communications malfunction between NAVI control unit and internal gyro	<ul style="list-style-type: none"> ● Navigation location detection performance has deteriorated. (Angular velocity cannot be detected.)
	<ul style="list-style-type: none"> ● Perform self-diagnosis. ● When the AV and NAVI control unit is judged normal by self-diagnosis, the symptom may be intermittent, caused by strong radio interference. 	
GPS disconnected	Communication error between AV and NAVI control unit and internal GPS substrate	<ul style="list-style-type: none"> ● Navigation location detection performance has deteriorated. (Location correction using GPS is not performed.) ● GPS receiving status remains gray.
	<ul style="list-style-type: none"> ● Perform self-diagnosis. ● When the AV and NAVI control unit is judged normal by self-diagnosis, the symptom may be intermittent, caused by strong radio interference. 	
GPS transmission cable malfunction	Malfunctioning transmission wires to AV and NAVI control unit and internal GPS substrate	<ul style="list-style-type: none"> ● During self-diagnosis, GPS diagnosis is not performed.
	<ul style="list-style-type: none"> ● Perform self-diagnosis. ● When the AV and NAVI control unit is judged normal by self-diagnosis, the symptom may be intermittent, caused by strong radio interference. 	
GPS input line connection error	Malfunctioning receiving wires to AV and NAVI control unit and internal GPS substrate	<ul style="list-style-type: none"> ● Navigation location detection performance has deteriorated. (Location correction using GPS is not performed.) ● GPS receiving status remains gray.
	<ul style="list-style-type: none"> ● Perform self-diagnosis. ● When the AV and NAVI control unit is judged normal by self-diagnosis, the symptom may be intermittent, caused by strong radio interference. 	
GPS TCX0 over GPS TCX0 under	Oscillating frequency of the GPS substrate frequency synchronizing oscillation circuit exceeded (or below) the specification	<ul style="list-style-type: none"> ● Navigation location detection performance has deteriorated. (Location correction using GPS is not performed.) ● GPS receiving status remains gray.
	<ul style="list-style-type: none"> ● Perform self-diagnosis. ● When the AV and NAVI control unit is judged normal by self-diagnosis, the symptom may be intermittent, caused by strong radio interference, or the control unit may have been subjected to excessively high or low temperatures. 	

NAVIGATION SYSTEM

Error item	Possible causes	Example of symptom
	Action/symptom	
GPS ROM malfunction GPS RAM malfunction	Contents of ROM (or RAM) in GPS substrate are malfunctioning.	<ul style="list-style-type: none"> ● Location detection accuracy of the navigation system will deteriorate, depending on the error area in the memory, because GPS cannot make correct positioning. (Location correction using GPS is not performed.)
	<ul style="list-style-type: none"> ● Perform self-diagnosis. ● When the AV and NAVI control unit is judged normal by self-diagnosis, the symptom may be intermittent, caused by strong radio interference. 	
GPS RTC malfunction	Clock IC in GPS substrate is malfunctioning.	<ul style="list-style-type: none"> ● Correct time may not be displayed. ● After the power is turned on, the system always takes some time until GPS positioning becomes possible. (The GPS receiver starts positioning without re-collecting the whole satellite information when it judged the data stored in the receiver is correct.) ● Correct time of error occurrence may not be stored in the "History of Errors".
	<ul style="list-style-type: none"> ● Perform self-diagnosis. ● When the AV and NAVI control unit is judged normal by self-diagnosis, the symptom may be intermittent, caused by strong radio interference. 	
GPS antenna disconnected	Malfunctioning connection between GPS substrate in AV and NAVI control unit and GPS antenna.	<ul style="list-style-type: none"> ● Navigation location detection performance has deteriorated. (Location correction using GPS is not performed.) ● GPS receiving status remains gray.
	<ul style="list-style-type: none"> ● Perform self-diagnosis. ● When connection between AV and NAVI control unit and GPS antenna is judged normal by self-diagnosis, the symptom may be intermittent, caused by impact or vibration. 	
Low voltage of GPS	The power voltage supplied to the GPS circuit board has decreased.	<ul style="list-style-type: none"> ● Navigation location detection performance has deteriorated. (Location correction using GPS is not performed.) ● GPS receiving status remains gray.
	<ul style="list-style-type: none"> ● Perform self-diagnosis. ● When connection between AV and NAVI control unit and GPS antenna is judged normal by self-diagnosis, the symptom may be intermittent, caused by impact or vibration. 	
DVD-ROM Malfunction DVD-ROM Read error DVD-ROM Response Error	Malfunctioning AV and NAVI control unit	-
	Dedicated map DVD-ROM is in the system, but the data cannot be read. <ul style="list-style-type: none"> ● Is map DVD-ROM damaged, warped, or dirty? <ul style="list-style-type: none"> – If damaged or warped, the map DVD-ROM is malfunctioning. – If dirty, wipe the DVD-ROM clean with a soft cloth. ● Perform self-diagnosis. ● When AV and NAVI control unit is judged normal by self-diagnosis, the symptom is judged intermittent, caused by vibration. 	<ul style="list-style-type: none"> ● The map of a particular location cannot be displayed. ● Specific guidance information cannot be displayed. ● Map display is slow. ● Guidance information display is slow. ● System has been affected by vibration.

NAVIGATION SYSTEM

CONSULT-II Function OPERATION PROCEDURE

AKS003XM

1. With the ignition switch OFF, connect "CONSULT-II" and "CONSULT-II CONVERTER" to the data link connector, and turn ignition switch ON.

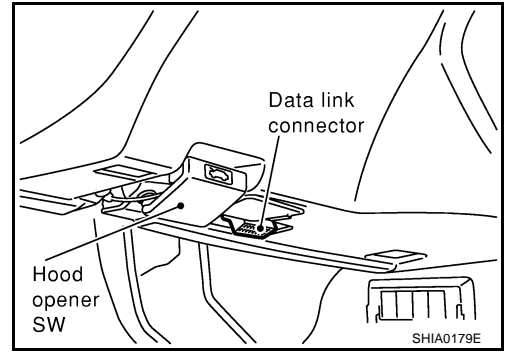

2. Touch "START (NISSAN BASED VHCL)".

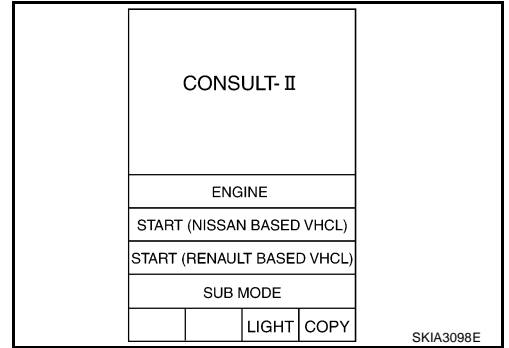

3. Touch "MULTIAV".
If "MULTIAV" is not indicated, go to [GI-38, "CONSULT-II Data Link Connector \(DLC\) Circuit"](#).

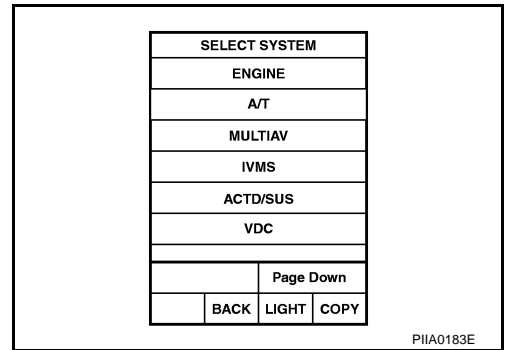

4. Select "VERSION", "SELF-DIAG RESULTS" or "SIGNAL MONITOR".

A
B
C
D
E
F
G
H
I
J
AV
L
M

NAVIGATION SYSTEM

SELF-DIAG RESULTS

- Checks for connection between each unit and analyzes each individual unit, then displays the results on the screen.

Items Shown

Items shown	Malfunctioning part/reference page
NO DTC IS DETECTED. FURTHER TESTING MAY BE REQUIRED.	-
HEAD UNIT ABNORMAL	AV and NAVI control unit malfunction
MAP DISC NO INSERT	Refer to AV-71, "Quick Reference Table" .
MAP DISC ABNORMAL	MAP DVD-ROM malfunction
MAP DISC DRIVER ABNORMAL 1	-
MAP DISC OR DRIVER ABNORMAL	Refer to AV-71, "Quick Reference Table" .
GPS ANTENNA NO CONNECTION	Refer to AV-71, "Quick Reference Table" .
PANEL SW ABNORMAL CONNECTION	Refer to AV-71, "Quick Reference Table" .
AUDIO HEAD UNIT ABNORMAL CONNECTION	Refer to AV-71, "Quick Reference Table" .
AIR COMP RECEIVER ABNORMAL CONNECTION	Refer to AV-71, "Quick Reference Table" .
BOSE AMP ABNORMAL CONNECTION	Refer to AV-71, "Quick Reference Table" .
BOSE AMP ABNORMAL	Bose amp malfunction
VOICE UNIT ABNORMAL CONNECTION	Refer to AV-71, "Quick Reference Table" .
VOICE UNIT ABNORMAL	Voice activated control module malfunction
PANEL SW ABNORMAL CONNECTION (MULTIFUNCTION SW)	Refer to AV-71, "Quick Reference Table" .

CAUTION:

When “IVCS ABNORMAL CONNECTION” and “REAR VIEW CAMERA ABNORMAL CONNECTION” are indicated, do not malfunction.

NAVIGATION SYSTEM

DATA MONITOR (SIGNAL MONITOR)

- Displays status of the vehicle signal input to the AV and NAVI control unit. (Refer to [AV-73. "Confirmation/Adjustment Mode"](#) for operation conditions for the connections to be indicated.)

DATA MONITOR			
MONITOR		NO DTC	
VHCL SPD SIG		OFF	
FOOT BRAKE		ON	
PARKING BRAKE		ON	
MTR ILL DIM		OFF	
IGN SW		ON	
PNP SW		ON	
		RECORD	
MODE	BACK	LIGHT	COPY

SKIA3923E

- For each signal, a comparison of actual operating status and the status recognized by the system can be checked.

DATA MONITOR item	Display	Condition	Remarks
VHCL SPD SIG	ON	Vehicle speed > 0 km/h (0 MPH)	Changes in indication may be delayed by approx. 1.5 seconds. This is normal.
	OFF	Vehicle speed = 0 km/h (0 MPH)	
	-	Ignition switch in ACC position	
FOOT BREAK	ON	-	This item cannot be monitored. (No change of display)
PARKING BRAKE	ON	-	This item cannot be monitored. (No change of display)
MTR ILL DIM	ON	Lighting switch ON	-
	OFF	Lighting switch OFF	
IGN SW	ON	Ignition switch ON	-
	OFF	Ignition switch ACC or OFF	
PNP SW	ON	-	This item cannot be monitored. (No change of display)

A
B
C
D
E
F
G
H
I
J
L
M

AV

NAVIGATION SYSTEM

VERSION

Displays version of each unit connected to the AV and NAVI control unit.

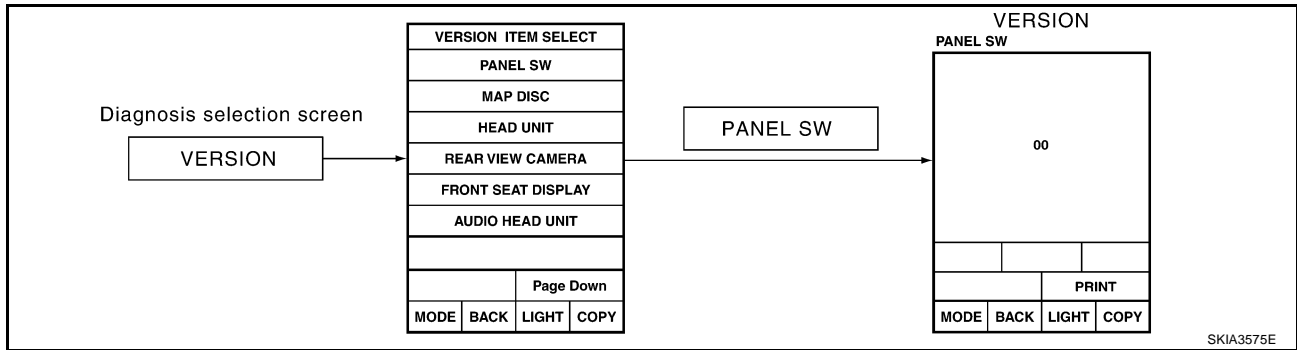

Version display	Remarks
"PANEL SW"	Multifunction switch
"MAP DISK"	Map disc
"HEAD UNIT"	AV and NAVI control unit
"REAR VIEW CAMERA"	-
"FRONT SEAT DISPLAY"	Display
"AUDIO HEAD UNIT"	-
"AIR COMP RECEIVER"	Low tire pressure warning control unit
"BOSE AMP"	-
"IVCS"	-
"VOICE UNIT"	Voice activated control module

NAVIGATION SYSTEM

AKS003XN

Power Supply and Ground Circuit Check

1. CHECK FUSE

- Make sure the following fuses of the AV and NAVI control unit are not blown.

Terminals		Power source	Fuse No.
Connector	Terminal (Wire color)		
B30	2 (SB), 3 (SB)	Battery power	52
B30	6 (L/B)	ACC power	21

OK or NG

OK >> GO TO 2.

NG >> If fuse is blown be sure to eliminate case of malfunction before installing new fuse. Refer to [PG-2](#), "[POWER SUPPLY ROUTING](#)".

2. POWER SUPPLY CIRCUIT CHECK

1. Disconnect the AV and NAVI control unit connector.
2. Check voltage between the following AV and NAVI control unit harness connector terminals and ground.

Terminals			OFF	ACC
(+)		(-)		
Connector	Terminal (Wire color)			
B30	2 (SB), 3 (SB)	Ground	Battery voltage	Battery voltage
B30	6 (L/B)	Ground	0V	Battery voltage

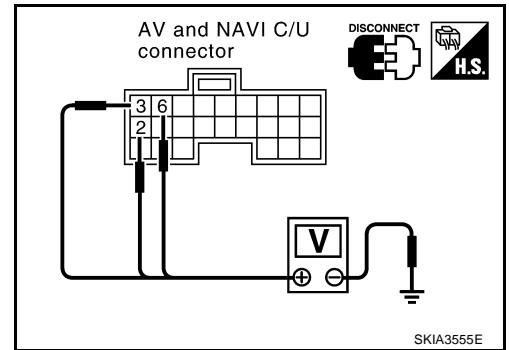

OK or NG

OK >> GO TO 3.

NG >> Check harness for open or short between AV and NAVI control unit and fuse.

3. GROUND CIRCUIT CHECK

Check continuity between the following AV and NAVI control unit and ground.

Terminals			Ignition switch	Continuity
(+)		(-)		
Connector	Terminal (Wire color)			
B30	1 (B), 4 (B)	Ground	OFF	Yes

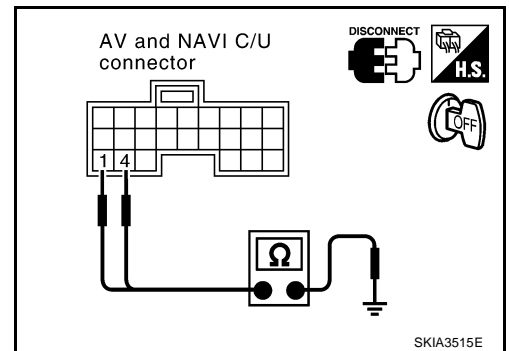

OK or NG

OK >> Inspection end.

NG >> Repair or replace harness.

NAVIGATION SYSTEM

AKS003XO

Vehicle Speed Signal Check

1. HARNESS CHECK

1. Turn ignition switch OFF.
2. Disconnect AV and NAVI control unit connector and combination meter connector.
3. Check continuity between AV and NAVI control unit harness connector B29 terminal 28 (OR/L) and combination meter harness connector M41 terminal 37 (OR/L).

28 (OR/L) - 37 (OR/L) : Continuity should exist.

4. Check continuity between AV and NAVI control unit harness connector B29 terminal 28 (OR/L) and ground.

28 (OR/L) - Ground : Continuity should not exist.

OK or NG

- OK >> GO TO 2.
 NG >> Repair harness.

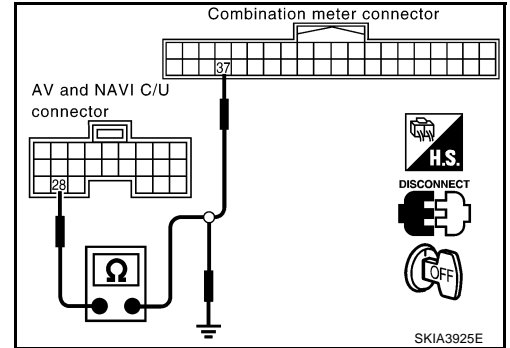

2. VEHICLE SPEED SIGNAL CHECK 2

1. Connect AV and NAVI control unit connector and combination meter connector.
2. Drive vehicle at a constant speed.
3. Check the signal between AV and NAVI control unit harness connector B29 terminal 28 (OR/L) and ground with CONSULT-II or oscilloscope.

28 (OR/L) - Ground : Refer to [AV-64, "Terminals and Reference Value for AV and NAVI Control Unit"](#) .

OK or NG

- OK >> Replace AV and NAVI control unit.
 NG >> Check combination meter system, refer to [DI-16, "Vehicle Speed Signal Inspection"](#) .

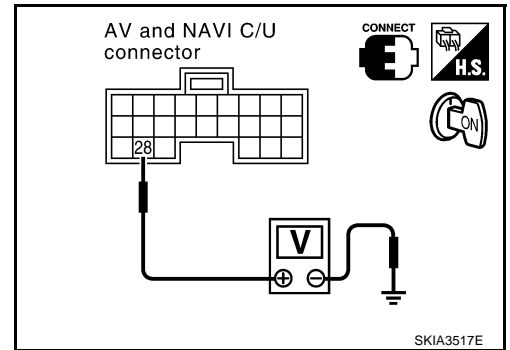

Illumination Control Signal Check

1. ILLUMINATION CONTROL SIGNAL CHECK

1. Turn ignition switch ON.
2. Check voltage between AV and NAVI control unit and ground.

Terminals		(-)	Lighting switch position	
(+)			1st or 2nd position	OFF
Connector	Terminal (Wire color)			
B29	25 (R/L)	Ground	Approx. 12V	Approx. 0V

OK or NG

- OK >> Replace AV and NAVI control unit.
 NG >> Check harness for open or short between AV and NAVI control unit and BCM.

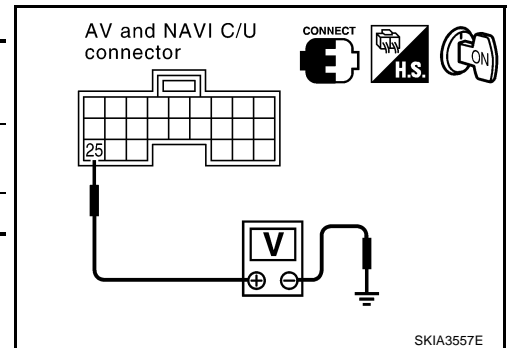

Ignition Signal Check

AKS003XQ

1. IGNITION SIGNAL CHECK

1. Turn ignition switch ON.
2. Check voltage between AV and NAVI control unit harness connector B29 terminal 26 (W/G) and ground.

26 (W/G) - Ground : Battery voltage should exist.

OK or NG

- OK >> Replace AV and NAVI control unit.
- NG >> Check harness for open or short between AV and NAVI control unit and fuse.

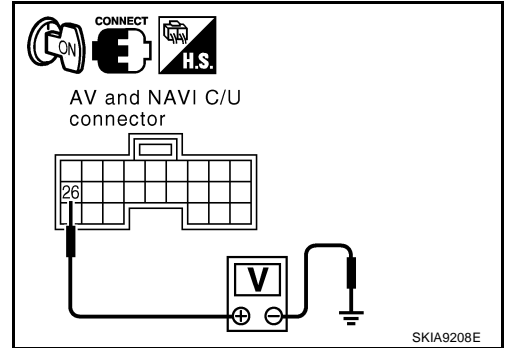

A
B
C
D
E
F
G
H
I
J
L
M

AV

NAVIGATION SYSTEM

AKS003XR

Reverse Signal Check

1. REVERSE LAMP CHECK

1. Turn ignition switch ON.
2. A/T shift selector lever into R-position. Does "R" in the shift position indicator come on?

YES or NO

YES >> GO TO 2.

NO >> Check back-up lamp system. Refer to [LT-106, "BACK-UP LAMP"](#) .

2. REVERSE SIGNAL CHECK

With the selector lever in R-position, Check voltage between AV and NAVI control unit and ground.

Terminals			A/T selector lever position	
(+)			R-position	Other than R-position
Connector	Terminal (Wire color)	(-)		
B29	27(R/B)	Ground	Battery voltage	Approx. 0V

OK or NG

OK >> Replace AV and NAVI control unit.

NG >> Check harness for open or short between AV and NAVI control unit and back-up lamp relay.

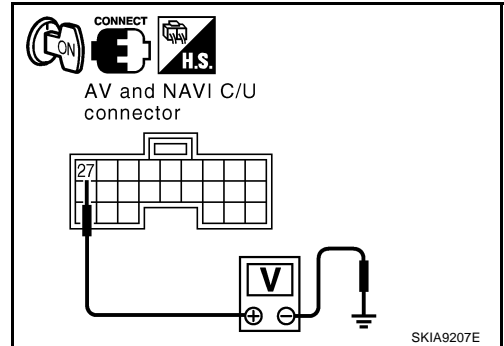

NAVIGATION SYSTEM

AKS003XS

RGB Screen is Not Shown

1. HARNESS CHECK

1. Turn ignition switch OFF.
2. Disconnect AV and NAVI control unit connector and Display connector.
3. Check continuity between AV and NAVI control unit harness connector B30 terminal 12(B) and Display harness connector M82 terminal 8 (B).

12 (B) - 8 (B) : Continuity should exist.

4. Check continuity between AV and NAVI control unit harness connector B30 terminal 13 (W) and Display harness connector M82 terminal 5 (W).

13 (W) - 5 (W) : Continuity should exist.

5. Check continuity between AV and NAVI control unit harness connector B30 terminal 12 (B), 13 (W) and ground.

12 (B), 13 (W) - Ground : Continuity should not exist.

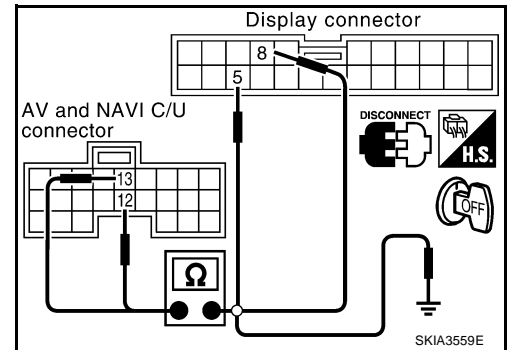

OK or NG

- OK >> GO TO 2.
NG >> Repair harness.

2. HORIZONTAL SYNCHRONIZATION SIGNAL CHECK

1. Connect AV and NAVI control unit connector and Display connector.
2. Turn ignition switch ON.
3. Check the signal between AV and NAVI control unit harness connector B30 terminals 13 (W) and 14 with CONSULT-II or oscilloscope.

13 (W) - 14 : Refer to [AV-64, "Terminals and Reference Value for AV and NAVI Control Unit"](#)

OK or NG

- OK >> GO TO 3.
NG >> Replace Display.

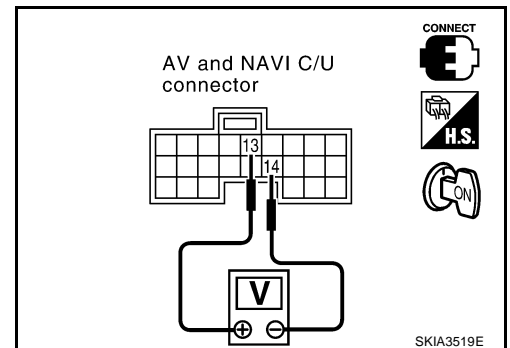

3. RGB AREA SIGNAL CHECK

1. Press "INFO" switch.
2. Check the signal between AV and NAVI control unit harness connector B30 terminals 12 (B) and 14 with CONSULT-II or oscilloscope.

12 (B) -14 : Refer to [AV-64, "Terminals and Reference Value for AV and NAVI Control Unit"](#) .

OK or NG

- OK >> Replace Display.
NG >> Replace AV and NAVI control unit.

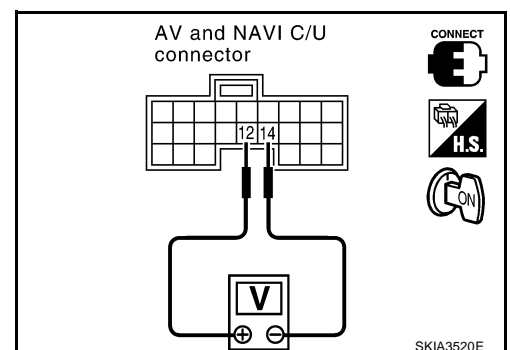

Color of RGB Image is Not Proper

AKS003XT

1. COLOR BAR DIAGNOSIS CHECK

Check color tone by "SCREEN ADJUSTMENT" of Confirmation/Adjustment Mode function.

OK or NG

OK >> Inspection end.
NG >> GO TO 2.

NAVIGATION SYSTEM

2. HARNESS CHECK

1. Turn ignition switch OFF.
2. Disconnect AV and NAVI control unit connector and Display connector.
3. Check continuity between AV and NAVI control unit and Display.
4. Check continuity between AV and NAVI control unit and ground.

● When the screen looks bluish

Terminals				Continuity
AV and NAVI control unit (+)		Display (-)		
Connector	Terminal (Wire color)	Connector	Terminal (Wire color)	
B30	18 (R/L)	M82	1 (R/L)	YES
B30	19	M82	4	YES

Terminals			Continuity
AV and NAVI control unit(+)		(-)	
Connector	Terminal (Wire color)		
B30	18 (R/L),19	Ground	NO

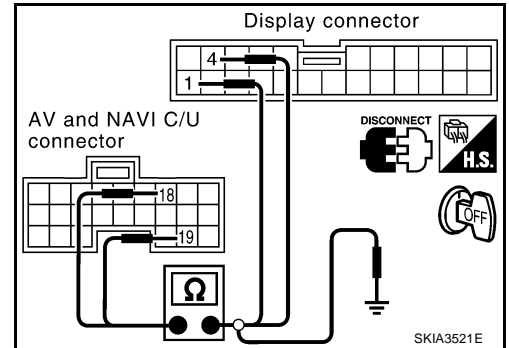

● When the screen looks reddish

Terminals				Continuity
AV and NAVI control unit (+)		Display (-)		
Connector	Terminal (Wire color)	Connector	Terminal (Wire color)	
B30	21 (R/W)	M82	2 (R/W)	YES
B30	19	M82	4	YES

Terminals			Continuity
AV and NAVI control unit(+)		(-)	
Connector	Terminal (Wire color)		
B30	19,21 (R/W)	Ground	NO

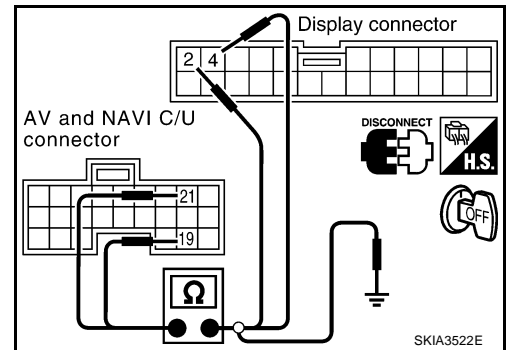

● When the screen looks yellowish

Terminals				Continuity
AV and NAVI control unit (+)		Display (-)		
Connector	Terminal (Wire color)	Connector	Terminal (Wire color)	
B30	15 (B)	M82	3 (B)	YES
B30	19	M82	4	YES

Terminals			Continuity
AV and NAVI control unit(+)		(-)	
Connector	Terminal (Wire color)		
B30	19,15 (B)	Ground	NO

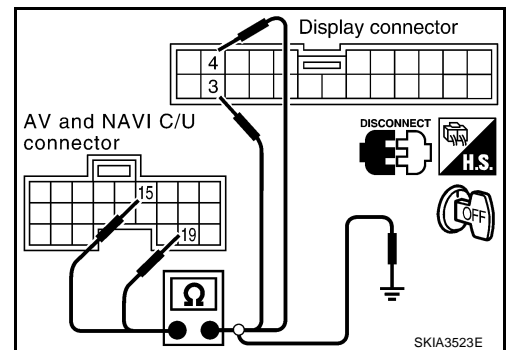

OK or NG

- OK >> GO TO 3.
- NG >> Repair harness.

NAVIGATION SYSTEM

3. RGB SIGNAL CHECK

1. Connect AV and NAVI control unit connector and Display connector.
2. Turn ignition switch ON.
3. Display "Color bar" by "Confirmation/Adjustment Mode" mode.
4. Check the following with CONSULT-II or oscilloscope.

- **When the screen looks bluish.**

Voltage signal between AV and NAVI control unit connector B30 terminal 18 (R/L) and 19.

18 (R/L) - 19

: Refer to [AV-64, "Terminals and Reference Value for AV and NAVI Control Unit"](#) .

- **When the screen looks reddish.**

Voltage signal between AV and NAVI control unit connector B30 terminal 21 (R/W) and 19.

21 (R/W) - 19

: Refer to [AV-64, "Terminals and Reference Value for AV and NAVI Control Unit"](#) .

- **When the screen looks yellowish.**

Voltage signal between AV and NAVI control unit connector B30 terminal 15 (B) and 19.

15 (B) - 19

: Refer to [AV-64, "Terminals and Reference Value for AV and NAVI Control Unit"](#) .

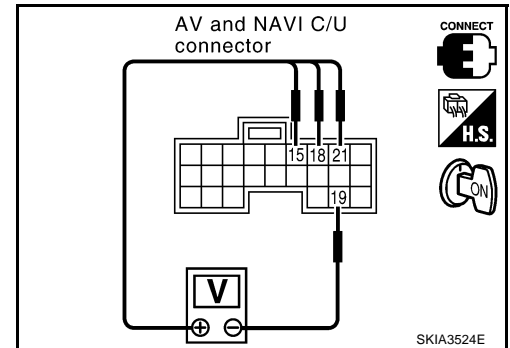

OK or NG

- OK >> Replace Display.
- NG >> Replace AV and NAVI control unit.

NAVIGATION SYSTEM

AKS003XU

RGB Screen is Rolling

1. HARNESS CHECK

1. Turn ignition switch OFF.
2. Disconnect AV and NAVI control unit connector and Display connector.
3. Check continuity between AV and NAVI control unit and Display.

Terminals				Continuity
AV and NAVI control unit (+)		Display (-)		
Connector	Terminal (Wire color)	Connector	Terminal (Wire color)	
B30	16 (G)	M82	7 (G)	YES

4. Check continuity between AV and NAVI control unit and ground.

Terminals			Continuity
AV and NAVI control unit (+)		(-)	
Connector	Terminal (Wire color)		
B30	16 (G)	Ground	NO

OK or NG

- OK >> GO TO 2.
 NG >> Repair harness.

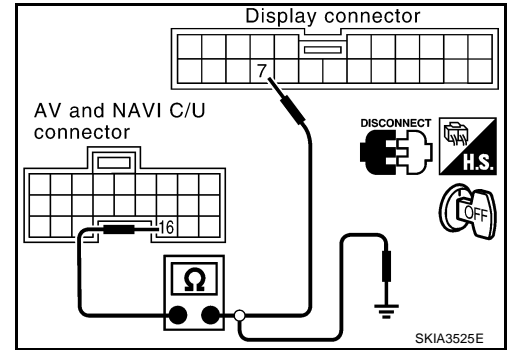

2. RGB SYNCHRONIZING SIGNAL CHECK

1. Connect AV and NAVI control unit connector and Display connector.
2. Turn ignition switch ON.
3. Check the signal between AV and NAVI control unit harness connector B30 terminals 16(G) and 14 with CONSULT-II or oscilloscope.

16(G) - 14

: Refer to AV-64, "Terminals and Reference Value for AV and NAVI Control Unit" .

OK or NG

- OK >> Replace Display.
 NG >> Replace AV and NAVI control unit.

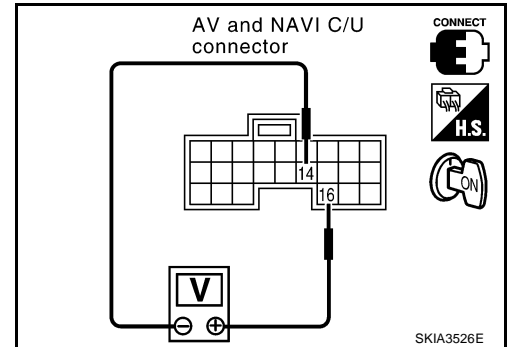

A
B
C
D
E
F
G
H
I
J
AV
L
M

Guide Sound is Not Heard

1. CHECK VOICE GUIDE SETTING

- While driving in the dark pink route, voice guide does not operate. (note)
- Is volume setting not switched ON?

NOTE:

Voice guide is only available at intersections that satisfy certain conditions (indicated by ● on the map). Therefore, guidance may not be given even when the route on the map changes direction.

YES or NO

- YES >> GO TO 2.
 NO >> Switch the setting ON and turn the volume up.

2. HARNESS CHECK

- Turn ignition switch OFF.
- Disconnect AV and NAVI control unit connector and Bose speaker amp. connector.
- Check continuity between AV and NAVI control unit and Bose speaker amp.

Terminals				Continuity
AV and NAVI control unit (+)		Bose speaker amp. (-)		
Connector	Terminal (Wire color)	Connector	Terminal (Wire color)	
B30	7 (R)	B231	1 (P)	YES
B30	8 (L)	B231	2 (L)	YES

- Check continuity between AV and NAVI control unit and ground.

Terminals			Continuity
AV and NAVI control unit(+)		(-)	
Connector	Terminal (Wire color)		
B30	7 (R),8 (L)	Ground	NO

OK or NG

- OK >> GO TO 3.
 NG >> Repair harness.

3. VOICE GUIDE CHECK

- Connect AV and NAVI control unit connector and Bose speaker amp. connector.
- Turn ignition switch ON.
- Check the signal between AV and NAVI control unit harness connector B30 terminal 7 (R) and 8 (L) with CONSULT-II or oscilloscope.

7 (R) - 8 (L)

: Refer to [AV-64, "Terminals and Reference Value for AV and NAVI Control Unit"](#) .

OK or NG

- OK >> Replace Bose speaker amp.
 NG >> Replace AV and NAVI control unit.

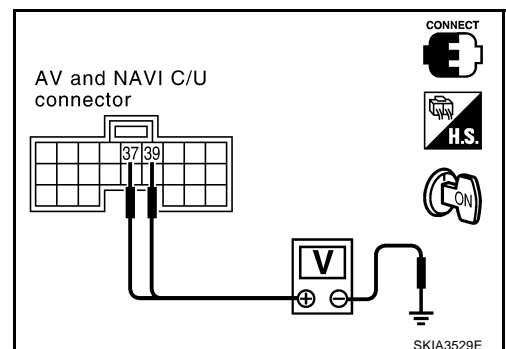
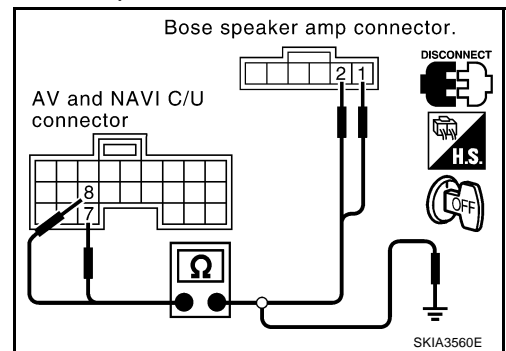

NAVIGATION SYSTEM

AKS003XW

A/C is Inoperrative (The Display for A/C is Not Shown)

1. HARNESS CHECK

1. Turn ignition switch OFF.
2. Disconnect A/C auto amp. connector and AV and NAVI control unit connector.
3. Check continuity between A/C auto amp. and AV and NAVI control unit.

Terminals				Continuity
AV and NAVI control unit (+)		A/C auto amp. (-)		
Connector	Terminal (Wire color)	Connector	Terminal (Wire color)	
B29	37 (L/W)	M119	9 (L/W)	YES
	39 (L/R)		20 (L/R)	

4. Check continuity between AV and NAVI control unit and ground.

Terminals				Continuity
AV and NAVI control unit (+)		(-)		
Connector	Terminal (Wire color)			
B29	37 (L/W)	Ground		NO
	39 (L/R)			

OK or NG

- OK >> GO TO 2.
 NG >> Repair harness.

2. A/C-AV, AC-CLK COMMUNICATION SIGNAL CHECK

1. Connect A/C auto amp. connector.
2. Turn ignition switch ON.
3. Check voltage between AV and NAVI control unit harness connector B29 terminal 37 (L/W), 39 (L/R) and ground.

37 (L/W), 39 (L/R) - Ground : Approx. 5V

OK or NG

- OK >> GO TO 3.
 NG >> Replace A/C auto amp.

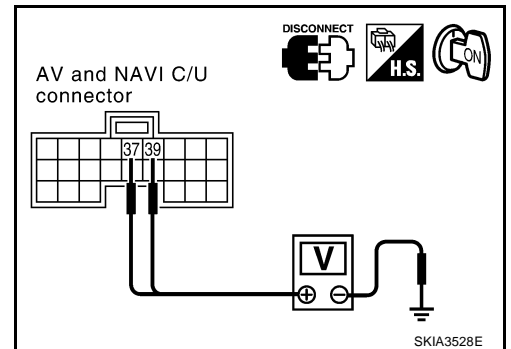
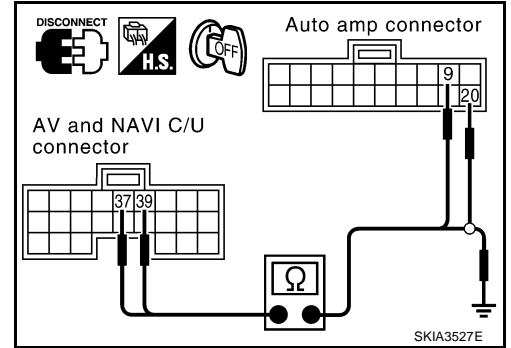

3. A/C-AV, AC-CLK COMMUNICATION SIGNAL CHECK

1. Connect AV and NAVI control unit connector.
2. Turn ignition switch ON.
3. Check the signal between AV and NAVI control unit harness connector B29 terminal 37 (L/W), 39 (L/R) and ground with CONSULT-II or oscilloscope.

37(L/W), 39(L/R) - Ground : Refer to AV-64, "Terminals and Reference Value for AV and NAVI Control Unit" .

OK or NG

- OK >> Replace A/C auto amp.
 NG >> Replace AV and NAVI control unit.

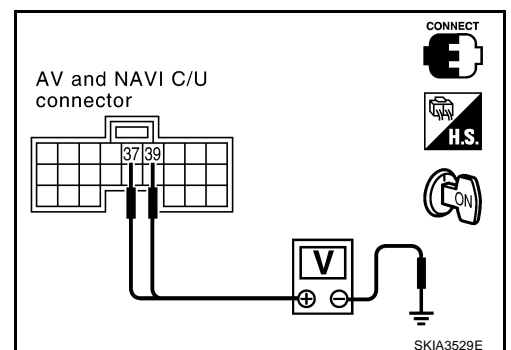

A/C is Inoperative (The Display for A/C is Shown)

1. HARNESS CHECK

1. Turn ignition switch OFF.
2. Disconnect A/C auto amp. connector and AV and NAVI control unit connector.
3. Check continuity between A/C auto amp. and AV and NAVI control unit.

Terminals				Continuity
AV and NAVI control unit (+)		A/C auto amp. (-)		
Connector	Terminal (Wire color)	Connector	Terminal (Wire color)	
B29	38 (L)	M119	10 (L)	YES

4. Check continuity between AV and NAVI control unit and ground.

Terminals			Continuity
AV and NAVI control unit (+)		(-)	
Connector	Terminal (Wire color)		
B29	38 (L)	Ground	NO

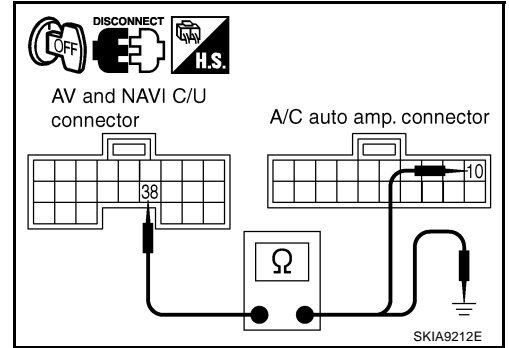

OK or NG

- OK >> GO TO 2.
- NG >> Repair harness.

2. AV-A/C, AC-CLK COMMUNICATION SIGNAL CHECK

1. Connect A/C auto amp. connector.
2. Turn ignition switch ON.
3. Check voltage between AV and NAVI control unit harness connector B29 terminal 38 (L) and ground.

38 (L) - Ground : Approx. 5V

OK or NG

- OK >> GO TO 3.
- NG >> Replace A/C auto amp.

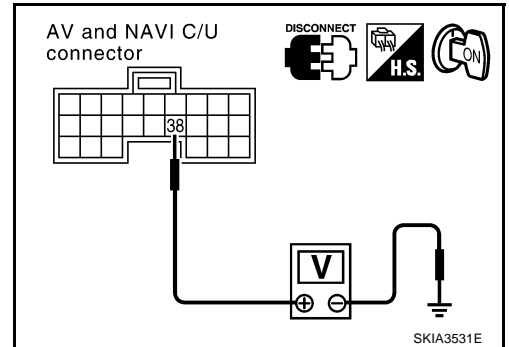

3. AV-A/C, AC-CLK COMMUNICATION SIGNAL CHECK

1. Connect AV and NAVI control unit connector.
2. Turn ignition switch ON.
3. Check the signal between AV and NAVI control unit harness connector B29 terminal 38 (L) and ground with CONSULT-II or oscilloscope.

38 (L) - Ground : Refer to [AV-64, "Terminals and Reference Value for AV and NAVI Control Unit"](#) .

OK or NG

- OK >> Replace A/C auto amp.
- NG >> Replace AV and NAVI control unit.

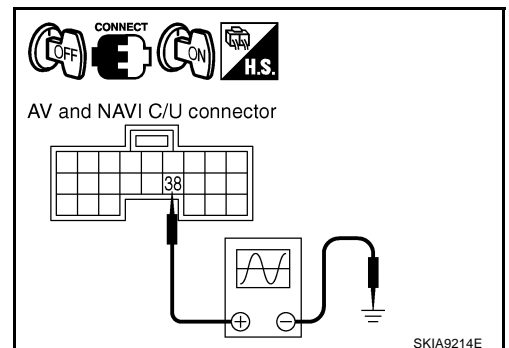

NAVIGATION SYSTEM

No Fuel Information is Displayed/No Warning Message is Displayed

AKS003XY

1. HARNESS CHECK

1. Turn ignition switch OFF.
2. Disconnect connectors of combination meter, BCM, and AV and NAVI control unit.
3. Check continuity between AV and NAVI control unit and combination meter.

Terminals				Continuity
AV and NAVI control unit (+)		combination meter (-)		
Connector	Terminal (Wire color)	Connector	Terminal (Wire color)	
B29	33 (LG)	M42	56 (LG)	YES
B29	32 (PU)	M42	57 (PU)	YES

4. Check continuity between AV and NAVI control unit and ground.

Terminals			Continuity
AV and NAVI control unit (+)		(-)	
Connector	Terminal (Wire color)		
B29	33 (LG)	Ground	NO
	32 (PU)		

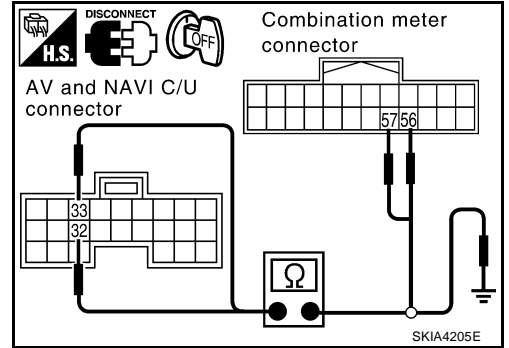

OK or NG

- OK >> GO TO 2.
 NG >> Repair harness.

2. COMMUNICATION SIGNAL (AV-ME) CHECK

1. Connect connectors of combination meter, BCM, and AV and NAVI control unit.
2. Turn ignition switch ON.
3. Check the signal between AV and NAVI control unit harness connector B29 terminal 33 (LG) and ground with CONSULT-II or oscilloscope.

33 (LG) - Ground : Refer to [AV-64, "Terminals and Reference Value for AV and NAVI Control Unit"](#) .

OK or NG

- OK >> GO TO 3.
 NG >> Replace AV and NAVI control unit.

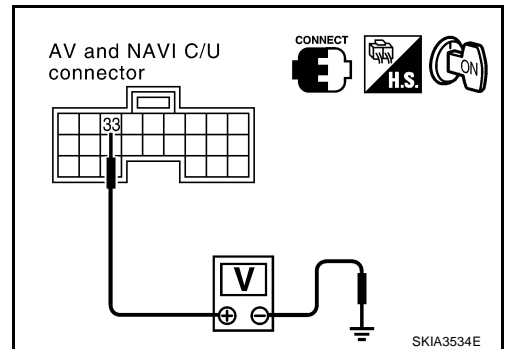

3. COMMUNICATION SIGNAL (ME-AV) CHECK

1. Turn ignition switch to ON and display "VEHICLE ELECTRONIC SYSTEMS" screen.
2. Check the signal between AV and NAVI control unit harness connector B29 terminal 32 (PU) and ground with CONSULT-II or oscilloscope.

32(PU) - Ground : Refer to [AV-64, "Terminals and Reference Value for AV and NAVI Control Unit"](#) .

OK or NG

- OK >> Replace AV and NAVI control unit.
 NG >> Replace combination meter.

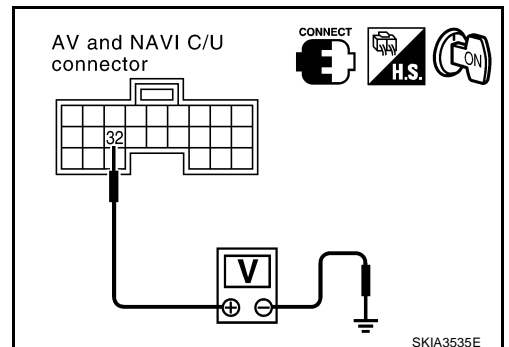

Vehicle Condition Setting is Not Possible

1. HARNESS CHECK

1. Turn ignition switch OFF.
2. Disconnect connectors of combination meter, BCM, and AV and NAVI control unit.
3. Check continuity AV and NAVI control unit and BCM.

Terminals				Continuity
AV and NAVI control unit (+)		BCM (-)		
Connector	Terminal (Wire color)	Connector	Terminal (Wire color)	
B29	33 (LG)	M4	31 (LG)	YES
	32 (PU)		30 (PU)	

4. Check continuity between AV and NAVI control unit and ground.

Terminals			Continuity
AV and NAVI control unit (+)		(-)	
Connector	Terminal (Wire color)		
B29	33 (LG)	Ground	NO
	32 (PU)		

OK or NG

OK >> GO TO 2.

- NG >> ● Check harness between AV and NAVI control unit and BCM for open or short circuit.
 ● Check connector housings for disconnected or loose terminals.

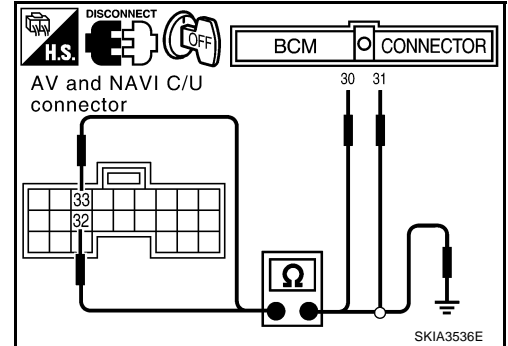

2. COMMUNICATION SIGNAL (AV-ME) CHECK

1. Connect connectors of combination meter, BCM, and AV and NAVI control unit.
2. Turn ignition switch ON.
3. Check the signal between AV and NAVI control unit harness connector B29 terminal 33 (LG) and ground with CONSULT-II or oscilloscope.

33 (LG) - Ground : Refer to [AV-64, "Terminals and Reference Value for AV and NAVI Control Unit"](#) .

OK or NG

OK >> GO TO 3.

NG >> Replace AV and NAVI control unit.

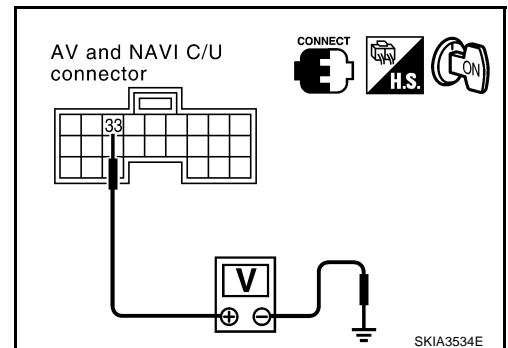

3. COMMUNICATION SIGNAL (ME-AV) CHECK

1. Turn ignition switch to ON and display "VEHICLE ELECTRONIC SYSTEMS" screen.
2. Check the signal between AV and NAVI control unit harness connector B29 terminal 32 (PU) and ground with CONSULT-II or oscilloscope.

32 (PU) - Ground : Refer to [AV-64, "Terminals and Reference Value for AV and NAVI Control Unit"](#) .

OK or NG

OK >> Replace AV and NAVI control unit.

NG >> Replace BCM.

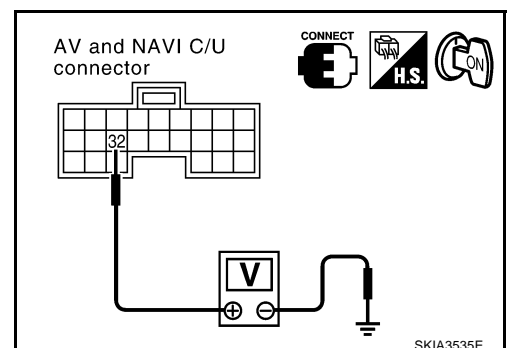

Previous Conditions are Not Stored

AKS003Y0

1. BATTERY POWER CHECK

- Check AV and NAVI control unit battery power.
Refer to [AV-83, "Power Supply and Ground Circuit Check"](#) .

OK or NG

- OK >> Replace AV and NAVI control unit
- NG >> Check AV and NAVI control unit battery power system harness

The Position of the Current-Location Mark is Not Correct

AKS003Y1

1. SELF-DIAGNOSIS

- "Self-diagnosis mode" of the self-diagnosis function [AV-69, "Self-Diagnosis Mode"](#) .

OK or NG

- OK >> GO TO 2.
- NG >> Check the applicable parts.

2. HISTORY OF ERRORS DIAGNOSIS

- Was any error stored in [AV-76, "HISTORY OF ERRORS"](#) of the Confirmation/Adjustment Mode mode?

YES or NO

- YES >> [AV-77, "DIAGNOSIS BY HISTORY OF ERRORS"](#).
- NO >> [AV-97, "Driving Test"](#)

Radio Wave from the GPS Satellite is Not Received

AKS003Y2

1. ENVIRONMENT CHECK

- Check if any metal object that intercepts radio waves or an object that emits radio waves (such as a portable phone) is located near the GPS antenna. Check if the vehicle is shielded by a building.

OK or NG

- OK >> ● System is not malfunction.
The GPS antenna may not be able to receive radio waves from the GPS satellite if it is shielded by metal object or an object emitting radio waves is placed near it.
- NG >> GO TO 2.

2. SELF-DIAGNOSIS

- "Self-diagnosis mode" of the self-diagnosis function. Refer to [AV-69, "Self-Diagnosis Mode"](#) .

OK or NG

- OK >> Replace GPS antenna.
- NG >> Check the applicable parts.

Driving Test

AKS003Y3

1. DRIVING TEST 1

1. Scroll the map screen to display the area to make correction. Press "ENTER" and select "CURRENT LOCATION CORRECTION".
2. Correct direction of the vehicle mark.
3. Perform the distance correction of the Confirmation/Adjustment Mode mode.
Note: Normally, adjustment is not necessary because this system has automatic distance correction function. However, when a tire chain is fitted, adjustment in accordance with the tire diameter ratio must be made.
4. Are symptoms applicable to the [AV-99, "Example of Symptoms Judged No Malfunction"](#) present after driving the vehicle?

YES or NO

- YES >> Limit of the location detection capacity of the navigation system
- NO >> GO TO 2.

NAVIGATION SYSTEM

2. DRIVING TEST 2

- Did any malfunction occur when the proper test in the following test patterns is performed?
- Test pattern
Driving test finds the difference between the symptoms monitored with and without each sensor.
- Test pattern 1: Test method with no GPS location correction
Disconnect the GPS antenna connector (GT5) connected to the AV and NAVI control unit. Accurately adjust the current position and the direction, then drive the vehicle.
- Test pattern 2: Test method with no map-matching
Accurately adjust the current position and the direction. Eject the map DVD-ROM from the AV and NAVI control unit with the ignition switch turned to OFF, then drive the vehicle. After driving, insert the map DVD-ROM back in the unit, display the track of the vehicle on the map screen and compare it with the actual road configuration.
- Sample tests
- <To determine if the current-location mark skips at the same position, if so, whether it is caused by map-matching or by GPS>
Perform test pattern 1.
- <To determine if the pattern of streets displayed is correct or not>
Perform test pattern 1&2.
Compare the track of the vehicle on the map screen and the actual road configuration. For fairly accurate tracking, plotting shall be made every several hundred meters.
- <When the distance is adjusted accurately>
Perform test pattern 1&2.
Drive on a road of which distance is accurately known (by utilizing distance posts on a highway). Calculate the rate of change (increased/decreased) of the distance by comparing with the actual distance.
Correction = A/B
A: Distance shown on the screen
B: Actual distance

YES or NO

- YES >> ● If adjustment is insufficient, perform adjustment again.
- If any error is found in the map, please let us know.
 - Replace AV and NAVI control unit.
- NO >> Limit of the location detection capacity of the navigation system

NAVIGATION SYSTEM

Example of Symptoms Judged No Malfunction BASIC OPERATION

AKS003Y4

Symptom	Cause	Remedy
No image is shown.	Display brightness adjustment is set fully to DARK side.	Adjust the display brightness.
No guide sound is heard. Audio guide volume is too low or too high.	Volume control is set to OFF, MIN or MAX.	Adjust the audio guide volume.
	Audio guidance is not available while the vehicle is driving on a dark pink route.	System is not malfunction.
Screen is too dark. Motion of the image is too slow.	Temperature inside the vehicle is low.	Wait until the temperature inside the vehicle reaches the proper temperature.
Small black or bright spots appear on the screen.	Symptom peculiar to a liquid crystal display.	System is not malfunction.

VEHICLE MARK

Symptom	Cause	Remedy
Map screen and BIRDVIEW TM name of the place vary with the screen.	Some thinning of the character data is done to prevent the display becoming to complex. In some cases and in some locations, the display contents may differ. The same place name, street name, etc. may not be displayed every time on account of the data processing.	System is not malfunction.
Vehicle mark is not positioned correctly.	Vehicle is transferred by ferry or by towing after its ignition switch is turned to OFF.	Drive the vehicle for a while in the GPS satellite signal receiving condition.
Screen will not switch to nighttime mode after the lighting switch is turned ON.	The daytime screen is selected by the "SWITCH SCREENS" when the last time the screen dimming setting is done. Switching between daytime/nighttime screen may be inhibited by the automatic illumination adjustment function.	Perform screen dimming and select the nighttime screen by "SWITCH SCREENS".
Map screen will not scroll in accordance with the vehicle travel.	Current location is not displayed.	Press "MAP" switch to display the current location.
Vehicle mark will not be shown.	Current location is not displayed.	Press "MAP" switch to display the current location.
Accuracy indicator (GPS satellite mark) on the map screen stays gray.	GPS satellite signal is intercepted because the vehicle is in or behind a building.	Move the vehicle out to an open space.
	GPS satellite signal cannot be received because an obstacle is placed on top of the display.	Do not place anything in the center on top of the display.
	GPS satellites are located badly.	Wait until the location becomes better.
Vehicle location accuracy is low.	Accuracy indicator (GPS satellite mark) on the map screen stays gray.	Current location is not determined.
	Vehicle speed setting by the vehicle speed pulse has been deviated (advanced or retarded) from the actual vehicle speed because tire chain is fitted or the system has been used on another vehicle.	Drive the vehicle for a while [for approx. 30 minutes at approx. 30 km/h (19MPH)] and the deviation will be automatically adjusted. If advancement or retard still occur, perform the distance adjustment by Confirmation/Adjustment Mode mode of diagnosis function.
	Map data has error or omission. (Vehicle mark is always deviated to the same position.)	As a rule, an updated map DVD-ROM will be released once a year.

NAVIGATION SYSTEM

DESTINATION, PASSING POINTS, AND MENU ITEMS CANNOT BE SELECTED/SET

Symptom	Cause	Remedy
Destination cannot be set.	Destination to be set is on an expressway.	Set the destination on an ordinary road.
Passing point is not searched when re-searching the route.	The vehicle has already passed the passing point, or the system judged so.	To include the passing points that have been passed into the route again, set the route again.
Route information will not be displayed.	Route searching has not been done.	Set the destination and perform route searching.
	Vehicle mark is not on the recommended route.	Drive on the recommended route.
	Route guide is turned OFF.	Turn the route guide ON.
	Route information is not available on the dark pink route.	System is not malfunction.
After the route searching, no guide sign will appear as the vehicle goes near the entrance/exit to the toll road.	Vehicle mark is not on the recommended route. (On the display, only guide signs related to the recommended route will be shown.)	Drive on the recommended route.
Automatic route searching is not possible.	Vehicle is driving on a highway (gray route), or no recommended route is available.	Drive on a road to be searched. Or re-search the route manually. In this case, however, the whole route will be searched.
Performed automatic detour search (or detour search). However, the result is the same as that of the previous search.	Performed search with every conditions considered. However, the result is the same as that of the previous search.	System is not malfunction.
Passing points cannot be set.	More than five passing points were set.	Passing points can be set up to five. To stop at more than five points, perform sharing in several steps.
When setting the route, the starting point cannot be selected.	The current vehicle location is always set as the starting point of a route.	System is not malfunction.
Some menu items cannot be selected.	The vehicle is being driven.	Stop the vehicle at a safe place and then operate the system.

VOICE GUIDE

Symptom	Cause	Remedy
Voice guide will not operate.	Note: Voice guide is only available at intersections that satisfy certain conditions (indicated by ● on the map). Therefore, guidance may not be given even when the route on the map changes direction.	System is not malfunction.
	The vehicle is not on the recommended route.	Return to the recommended route or re-search the route.
	Voice guide is turned OFF.	Turn the voice guide ON.
	Route guide is turned OFF.	Turn the route guide ON.
Voice guide does not match the actual road pattern.	Voice guide may vary with the direction to which the vehicle is turn and the connection of the road to other roads.	Drive in conformity to the actual traffic rules.

NAVIGATION SYSTEM

ROUTE SEARCHING

Symptom	Cause	Remedy
No route is shown.	No road to be searched is found around the destination.	Find wider road (orange road or wider) nearby and reset the destination and passing points onto it. Take care of the traveling direction when there are separate up and down roads.
	Starting point and the destination are too close.	Set the destination at more distant point.
	Conditional traffic regulation (day of the week/ time of the day) is set at the area around the current position or the destination.	Turn the time-regulating search conditions OFF. Turn "Avoid regulation time" in the search conditions OFF.
Indicated route is intermittent.	In some areas, highways (gray routes) are not used for the search ^(Note) Therefore, the route to the current position or the passing points may be intermittent.	System is not malfunction.
When the vehicle has passed the recommended route, it is deleted from the screen.	A recommended route is controlled by each section. When the vehicle has passed the passing point 1, then the map data from the starting point up to the passing point 1 will be deleted. (The data may remain undeleted in some area.)	System is not malfunction.
Detouring route is recommended.	In some areas, highways (gray routes) are not used for the search. (Note). Therefore, detour route may be recommended.	Set the route closer to the basic route (gray route).
	A detour route may be shown when some traffic regulation (one-way traffic, etc.) is set at the area around the starting point or the destination.	Slightly move the starting point or the destination, or set the passing point on the route of your choice.
	In the area where highways (gray routes) are used for the search, left turn has priority around the current position and the destination (passing points). For this reason, the recommended route may be detouring.	System is not malfunction.
Landmarks on the map do not match the actual ones.	This can be happen due to omission or error in the map data.	As a rule, an updated map DVD-ROM will be released once a year. Wait until the latest map has become available.
Recommended route is far from the starting point, passing points, and destination.	Starting point, passing points, and destination of the route guide were set far from the desired points because route searching data around these area were not stored.	Reset the destination onto the road nearby. If this road is one of the highways (gray routes), an ordinary road nearby may be displayed as the recommended route.

NOTE:

Except for the ordinance-designated cities and the prefectural capitals (Applicable areas may be changed in the updated map disc.)

A
B
C
D
E
F
G
H
I
J
AV
L
M

NAVIGATION SYSTEM

EXAMPLES OF CURRENT-LOCATION MARK DISPLACEMENT

Vehicle's travel amount is calculated by reading its travel distance and turning angle. Therefore, if the vehicle is driven in the following manner, an error will occur in the vehicle's current location display. If correct location has not been restored after driving the vehicle for a while, perform location correction.

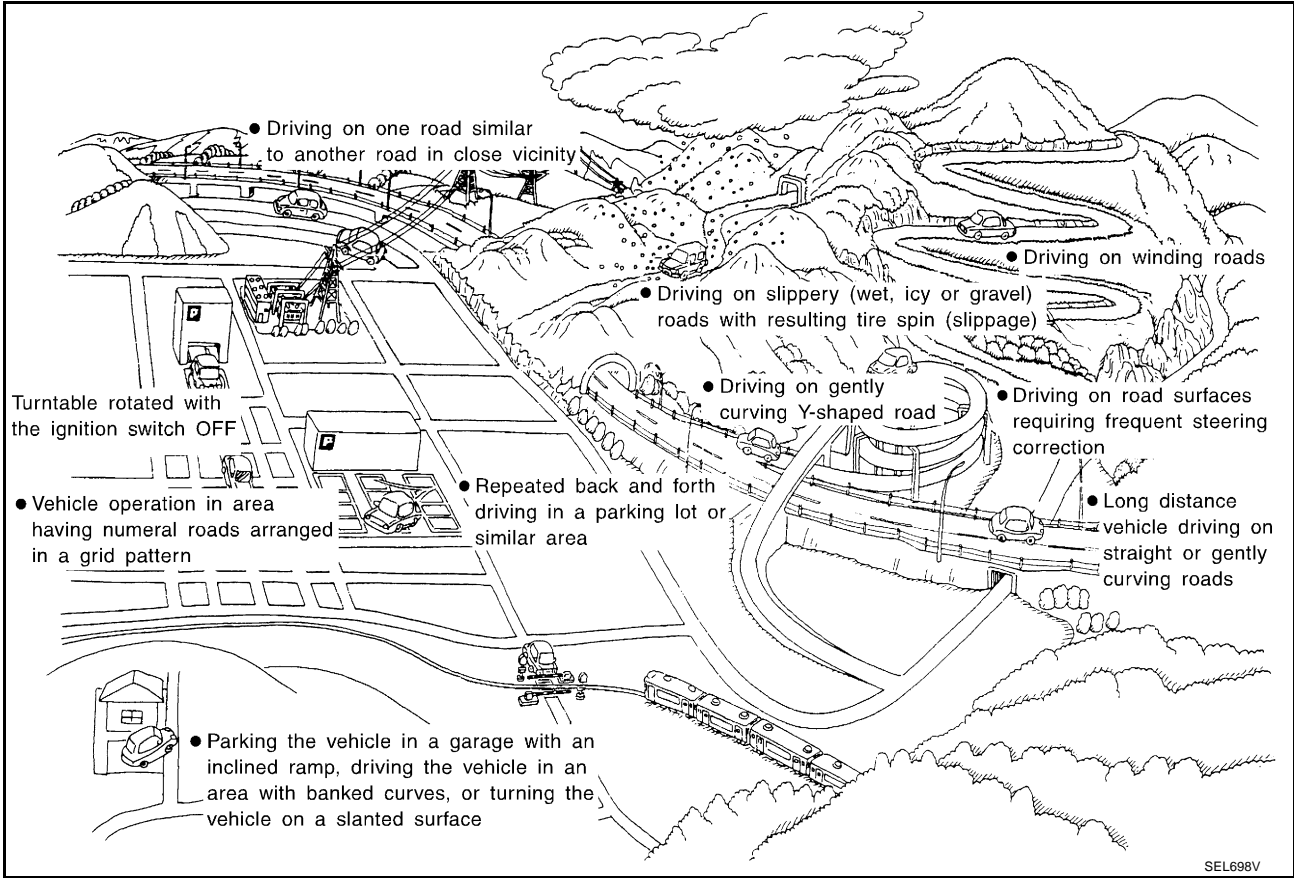

NAVIGATION SYSTEM

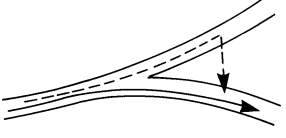
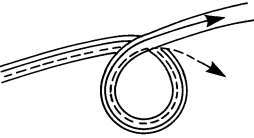
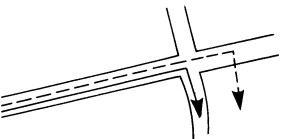
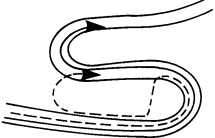
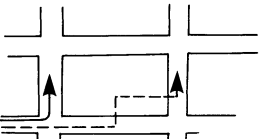
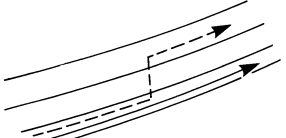
	Cause (condition) - :While driving ooo:Display	Driving condition	Remarks (correction, etc.)
Road configuration	<p>Y-intersections</p>  <p style="text-align: right; font-size: small;">ELK0192D</p>	<p>At a Y intersection or similar gradual division of roads, error the direction of travel deduced by the sensor may result in the current-location mark appearing on the wrong road.</p>	<p>If after travelling about 10 km (6 miles) the correct location has not been restored, perform location correction and, if necessary, direction correction.</p>
	<p>Spiral roads</p>  <p style="text-align: right; font-size: small;">ELK0193D</p>	<p>When driving on a large, continuous spiral road (such as loop bridge), turning angle error is accumulated and the vehicle mark may deviate from the correct location.</p>	
	<p>Straight roads</p>  <p style="text-align: right; font-size: small;">ELK0194D</p>	<p>When driving on a long, straight road and slow curve without stopping, map-matching does not work effectively enough and distance errors may accumulate. As a result, the vehicle mark may deviate from the correct location when the vehicle turned at a corner.</p>	
	<p>Zigzag roads</p>  <p style="text-align: right; font-size: small;">ELK0195D</p>	<p>When driving on a zigzag road, the map may be matched to other roads in the similar direction nearby at every turn, and the vehicle mark may deviate from the correct location.</p>	
	<p>Roads laid out in a grid pattern</p>  <p style="text-align: right; font-size: small;">ELK0196D</p>	<p>When driving at where roads are laid out in a grid pattern, where many roads are running in the similar direction nearby, the map may be matched to them by mistake and the vehicle mark may deviate from the correct location.</p>	
	<p>Parallel roads</p>  <p style="text-align: right; font-size: small;">ELK0197D</p>	<p>When two roads are running in parallel (such as highway and sideways), the map may be matched to the other road by mistake and the vehicle mark may deviate from the correct location.</p>	

A
B
C
D
E
F
G
H
I
J
AV
L
M

NAVIGATION SYSTEM

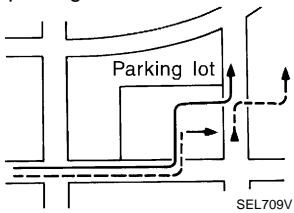
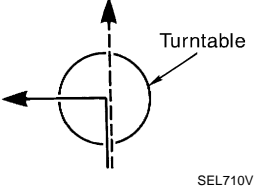
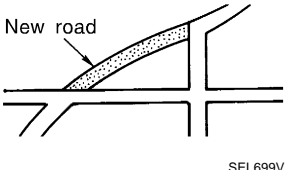
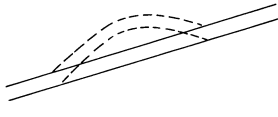
	Cause (condition) -:While driving ooo:Display	Driving condition	Remarks (correction, etc.)
Place	In a parking lot 	When driving in a parking lot, or other location where there are no roads on the map, matching may place the vehicle mark on a nearby road. When the vehicle returns to the road, the vehicle mark may have deviated from the correct location. When driving in circle or turning the steering wheel repeatedly, direction errors accumulate, and the vehicle mark may deviate from the correct location.	If after travelling about 10 km (6 miles) the correct location has not been restored, perform location correction and, if necessary, direction correction.
	Turn table 	When the ignition switch is OFF, the navigation system cannot get the signal from the gyroscope (angular speed sensor). Therefore, the displayed direction may be wrong and the correct road may not be easily returned to after rotating the vehicle on a turn table with the ignition OFF.	
	Slippery roads	On snow, wet roads, gravel, or other roads where tires may slip easily, accumulated mileage errors may cause the vehicle mark to deviate from the correct road.	
	Slopes	When parking in sloped garages, when travelling on banked roads, or in other cases where the vehicle turns when tilted, an error in the turning angle will occur, and the vehicle mark may deviate from the road.	
Map data	Road not displayed on the map screen 	When driving on new roads or other roads not displayed on the map screen, map matching does not function correctly and matches the location to a nearby road. When the vehicle returns to a road which is on the map, the vehicle mark may deviate from the correct road.	
	Different road pattern (Changed due to repair) 	If the road pattern stored in the map data and the actual road pattern are different, map matching does not function correctly and matches the location to a nearby road. The vehicle mark may deviate from the correct road.	
Vehicle	Use of tire chains	When tire chains are used, the mileage is not correctly detected, and the vehicle mark may deviate from the correct road.	Drive the vehicle for a while. If the distance is still deviated, adjust it by using the distance adjustment function. (If the tire chain is removed, recover the original value.)

NAVIGATION SYSTEM

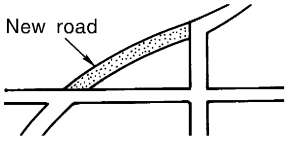
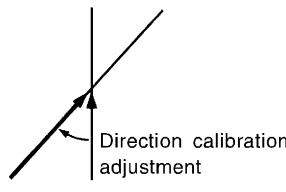
Cause (condition) -:While driving ooo:Display	Driving condition	Remarks (correction, etc.)
Precautions for driving	Just after the engine is started	If the vehicle is driven off just after the engine is started when the gyroscope (angular speed sensor) correction is not completed, the vehicle can lose its direction and may have deviated from the correct location. Wait for a short while before driving after starting the engine.
	Continuous driving without stopping	When driving long distances without stopping, direction errors may accumulate, and the current-location mark may deviate from the correct road. Stop and adjust the orientation.
	Abusive driving	Spinning the wheels or engaging in other kinds of abusive driving may result in the system being unable perform correct detection, and may cause the vehicle mark to deviate from the correct road. If after travelling about 10 km (6 miles) the correct location has not been restored, perform location correction and, if necessary, direction correction.
How to correct location	Position correction accuracy 	If the accuracy of location settings is poor, accuracy may be reduced when the correct road cannot be found, particularly in places where there are many roads. CAUTION: Whenever possible, use detailed map for the correction.
	Direction when location is corrected 	If the accuracy of location settings during correction is poor, accuracy may be reduced afterwards. Perform direction correction.

THE CURRENT POSITION MARK SHOWS A POSITION WHICH IS COMPLETELY WRONG

In the following cases, the current-location mark may appear on completely different position in the map depending on the GPS satellite signal receiving conditions. In this case, perform location correction and direction correction.

- When location correction has not been done
 - If the receiving conditions of the GPS satellite signal is poor, if the current-location mark becomes out of place, it may move to a completely different location and not come back if location correction is not done. The position will be corrected if the GPS signal can be received.
- When the vehicle has traveled by ferry, or when the vehicle has been being towed
 - Because calculation of the current location cannot be done when travelling with the ignition OFF, for example when traveling by ferry or when being towed, the location before travel is displayed. If the precise location can be detected with GPS, the location will be corrected.

THE CURRENT POSITION MARK JUMPS

In the following cases, the current-location mark may appear to jump as a result of automatic correction of the current location.

- When map matching has been done
 - If the current location and the current-location mark are different when map matching is done, the current-location mark may seem to jump. At this time, the location may be "corrected" to the wrong road or to a location which is not on a road.
- When GPS location correction has been done
 - If the current location and the current-location mark are different when the location is corrected using GPS measurements, the current-location mark may seem to jump. At this time, the location may be "corrected" to a location which is not on a road.

NAVIGATION SYSTEM

THE CURRENT LOCATION MARK IS IN A RIVER OR THE SEA

The navigation system moves the current location mark with no distinction between land and rivers or sea. If the location mark is somehow out of place, it may appear that the vehicle is driving in a river or the sea.

WHEN DRIVING ON THE SAME ROAD, SOMETIMES THE CURRENT-LOCATION MARK IS IN THE RIGHT PLACE AND SOMETIMES IT IS THE WRONG PLACE

The conditions of the GPS antenna (GPS data) and gyroscope (angular speed sensor) change gradually. Depending on the road traveled and the operation of the steering wheel, the location detection results will be different. Therefore, even on a road on which the location has never been wrong, conditions may cause the vehicle mark to deviate.

LOCATION CORRECTION BY MAP MATCHING IS SLOW

- The map matching function needs to refer to the data of the surrounding area. It is necessary to drive some distance for the function to work.
- Because map matching operates on this principle, when there are many roads running in similar directions in the surrounding area, no matching determination may be made. The location may not be corrected until some special feature is found.

ALTHOUGH THE GPS RECEIVING DISPLAY IS GREEN, THE VEHICLE MARK DOES NOT RETURN TO THE CORRECT LOCATION

- The GPS accuracy has an error of about 10 m (30 ft). In some cases the current-location mark may not be on the correct street, even when GPS location-correction is done.
- The navigation system compares the results of GPS location detection with the results from map-matching location detection. The one which is determined to have higher accuracy is used.
- GPS location correction may not be performed when the vehicle is stopped.

THE NAME OF THE CURRENT PLACE IS NOT DISPLAYED

The current place name may not be displayed if there are no place names displayed on the map screen.

CONTENTS OF THE DISPLAY DIFFER FOR THE BIRDVIEW™ AND THE (FLAT) MAP SCREEN

Difference of the BIRDVIEW™ screen from the flat map screen are as follows.

- The current place name displays names which are primarily in the direction of vehicle travel.
- The amount of time before the vehicle travel or turn angle is updated on the screen is longer than for the (flat) map display.
- The conditions for display of place names, roads, and other data are different for nearby areas and for more distant areas.
- Some thinning of the character data is done to prevent the display becoming too complex. In some cases and in some locations, the display contents may differ.
- The same place name, street name, etc. may be displayed multiple times.

NAVIGATION SYSTEM

Program Loading

AKS003Y5

A
B
C
D
E
F
G
H
I
J
AV
L
M

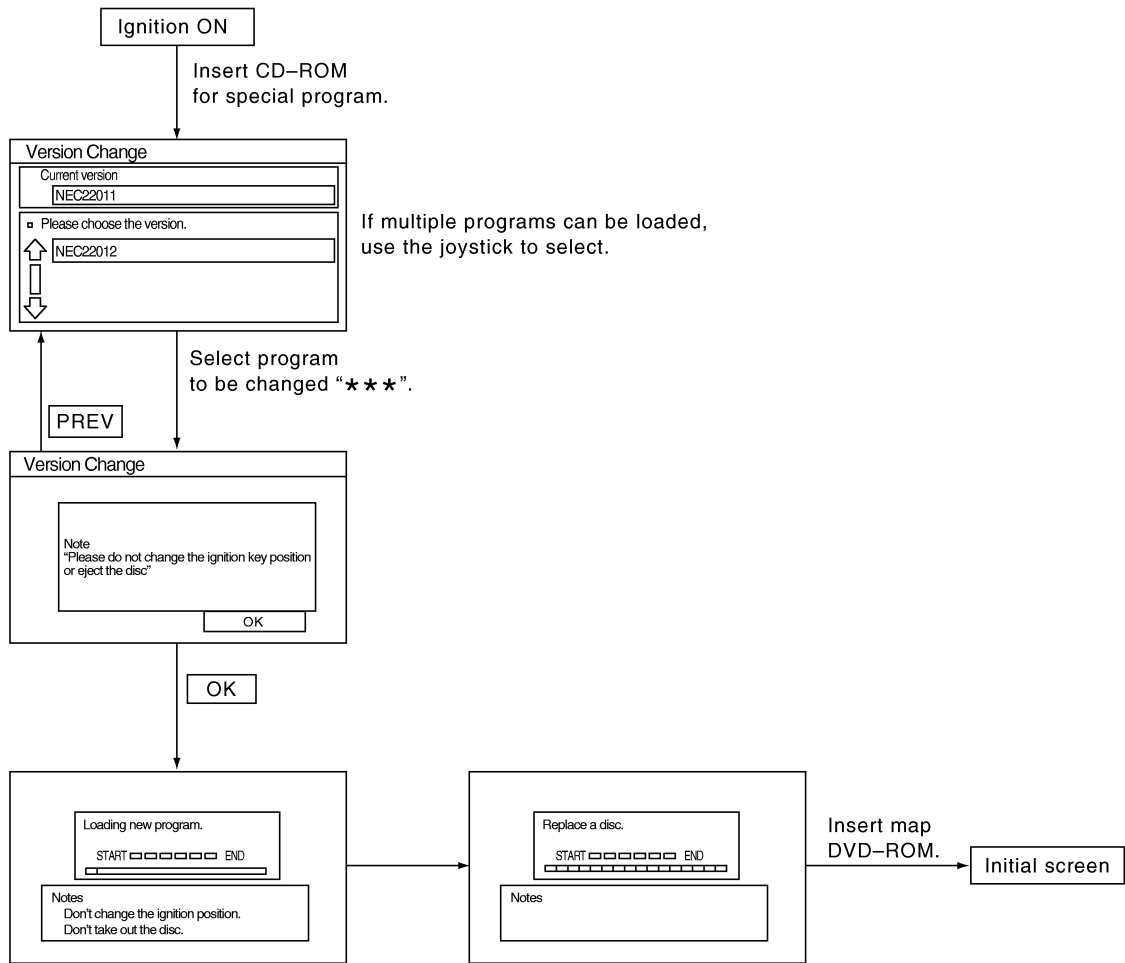

NOTE: Always load a program with the engine running.

SKIA0389E

NAVIGATION SYSTEM

Removal and Installation of AV and NAVI Control Unit

AKS002P6

REMOVAL

1. Refer to [AV-49, "Precautions for AV and NAVI Control Unit Replacement"](#) . Take a note of necessary items.
2. Remove trunk front finisher. Refer to [EI-42, "Removal and Installation"](#) .
3. Remove screws (4), and remove AV and NAVI control unit with power tool.

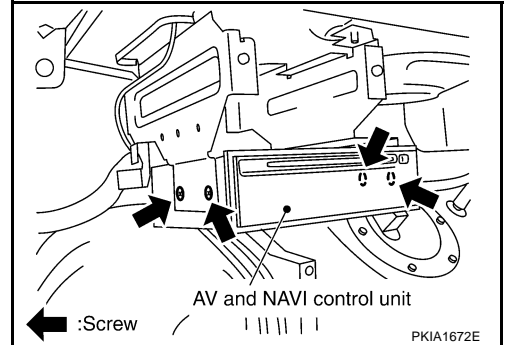

INSTALLATION

Install in the reverse order of removal.

Removal and Installation of GPS Antenna

AKS002P7

REMOVAL

1. Remove trunk front finisher, and disconnect GPS antenna harness connector. Refer to [EI-42, "Removal and Installation"](#) .
2. Remove rear parcel shelf finisher. Refer to [EI-37, "REAR PARCEL SHELF FINISHER"](#) .
3. Remove screws (2), and remove GPS antenna.

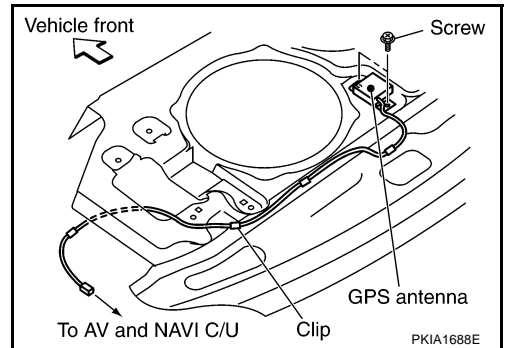

INSTALLATION

Install in the reverse order of removal.

Removal and Installation of Steering Wheel Switch

AKS002P8

Refer to [SRS-38, "DRIVER AIR BAG MODULE"](#) .